

Cable diagnostic in MV underground cable networks

Theoretical background and practical application

- VLF testing
- tan delta loss factor measurement
- Partial discharge localization and measurement

Author: Tobias Neier, Ing., MBA

Table of Contents

1	Introduction	5
2	VLF Testing	6
2.1	Why should VLF be used for testing of MV underground cables?	6
2.1.1	Withstand Test with VLF	6
2.1.2	Why DC test may not be used for XLPE cables?	6
2.1.3	Requirements for Cable Testing and Standards	7
2.1.4	Technical reasons using VLF.....	8
2.1.5	Commercial reasons using VLF	8
2.1.6	General strategic reasons using VLF	8
2.2	Standards for high voltage field testing for HV cables.....	9
2.3	Testing and Diagnostic according to standards	10
2.3.1	IEC 60060-3	11
2.3.2	IEC 60502-2 Edition 3.0 / 2014-02	12
2.3.3	CENELEC HD 620 (S1), VDE 0267 HD S1 (1996)	14
2.3.4	IEEE STD. 400.2	15
3	Monitored Withstand Test (MWT)	20
4	Practical recommendation for implementation of testing voltages in respect to the standards	28
5	Discussion on Dielectric Response in XLPE/PILC Cables	29
6	Combined TD/PD Cable Diagnostic.....	31
6.1	Why to use VLF Diagnostic	32
6.1.1	Dissipation factor: VLF versus power frequency	32
6.1.2	PD: VLF versus Power Frequency.....	32
7	TD Loss Factor Measurement - TanDelta.....	33
7.1	Basic background of Tan δ Dissipation factor (TD)	33
7.2	Water Tree - Electrical Tree	35
7.3	Tan δ Measurements on Service Aged Cables	37
7.4	Tan δ - Measurement at lower test voltages.....	39
7.5	TD Evaluation – important parameters / Influences	40
7.5.1	Important Parameter for TD interpretation	40
7.5.2	TD Stability Trend Analysis.....	43
7.5.3	Basic pattern of TD Trend Analysis based on cable elements.....	44
7.5.4	Examples for TD measurement – Trend of stability	54
7.5.5	TD measurement – Result comparison over time	55
7.5.6	Influence of surface currents in open terminations.....	56
7.6	Recommended approach for TD Evaluation	58
7.6.1	Loss factor measurement at XLPE cables	58
7.6.2	Loss factor measurement at PILC	58
7.6.3	Loss factor measurement at mixed cable circuits:	58
7.6.4	Viewing points / Definitions used for evaluation:	59
7.6.5	TanDelta as measuring tool for humidity in cable accessories	62
7.6.6	Newly implemented Evaluation Criteria for TanDelta Loss Factor Measurement acc. to IEEE 400.2-2013.....	63
8	PD Partial Discharge Localization and Level Measurement	69
8.1	Background.....	69

8.2	Partial discharge measurement according to IEC 60270	70
8.3	Calibration	73
8.4	Make use of the calibration graph	73
8.4.1	Partial discharge measurement at VLF and other test voltage waveforms	76
8.5	Advantages of VLF PD Diagnostic.....	77
8.6	PD Inception (PDIV) and PD Extinction (PDEV) voltage	78
8.7	PD result interpretation – guidelines.....	79
8.7.1	PD measurements at XLPE cables.....	79
8.7.2	PD measurements at PILC and mixed cable circuits.....	80
9	Other Dielectric Diagnostic Methods – Their Theory and Suitability	81
9.1	Cable Diagnostic System KDA 1 – IRC - Analysis	82
9.2	Cable Diagnostic System CD30/31- Return Voltage Method.....	83
9.3	Insulation Diagnostic System IDA 200 – Sine Correlation Technique.....	84
9.4	Cable Testing and Diagnostic System PHG TD	85
10	Report example.....	86
10.1	Field examples for basic understanding.....	86
10.1.1	Example 1: Requirement of sensitivity of TD measuring system	86
10.1.2	Example 2: TD measurement influenced by water ingress into joints.....	87
10.2	Report Example for Combined TD / PD Diagnostic	89
11	Latest projects of BAUR Diagnostic Services	95
11.1	Hong Kong Electric.....	95
11.2	KEPCO Korea	98
11.3	Western Power / Australia	100
11.4	Other cooperations	101
11.5	BAUR Diagnostic platform	101
12	Appendix – Case Studies combined diagnostics.....	102
12.1	Case Study A 1 - 11153	102
12.1.1	Cable Layout.....	103
12.1.2	TD result 06.12.2011.....	103
12.1.3	PD Result recorded on 06.12.2011	104
12.1.4	Required action and conclusion – step 1.....	106
12.1.5	Cable Dissection.....	107
12.1.6	TD result 31.01.2012.....	108
12.1.7	Result comparison, before and after joint replacement.....	109
12.1.8	PD result 31.01.2012.....	110
12.1.9	Required action and conclusion – step 2.....	110
12.2	Case Study H 2 - 5532	111
12.2.1	Cable Layout.....	112
12.2.2	TD result.....	112
12.2.3	TD result interpretation	113
12.2.4	PD Result	114
12.2.5	PD interpretation	115
12.2.6	Diagnostic analysis	115
12.2.7	Conclusion and recommendation.....	116
12.3	Case Study H 3 - 5360	117
12.3.1	Cable Layout.....	118
12.3.2	TD result 16.04.2013.....	118
12.3.3	TD result interpretation	119
12.3.4	PD Result 16.04.2014.....	120

12.3.5	Diagnostic Analysis.....	121
12.3.6	Recommended approach - action.....	122
12.3.7	TD result 10.05.2014, <i>retest after joint replacement</i>	123
12.3.8	Result comparison, before and after joint replacement	124
12.3.9	PD result 31.01.2012 - after joint replacement.....	124
12.3.10	Conclusion	124
12.4	Case Study H 4 - 4285	125
12.4.1	Cable Layout / Structure	126
12.4.2	History	127
12.4.3	TD & PD Measurement results	128
12.4.4	TD Result recorded on 13 JUL 2011	129
12.4.5	PD measuring result after replacement of 169m cable section on 13 JUL	131
12.4.6	TD PD Diagnostic Summary.....	132
12.4.7	Cable fault on 30 JUL 2011.....	132
12.4.8	TD Measurement on 31 JUL 2011.....	133
12.4.9	Joint dissection.....	136
12.4.10	Required action and conclusion.....	137
12.5	Case Study H 5 -391	138
12.5.1	History	139
12.5.2	Partial Discharge Measurement 06.06.2010	142
12.5.3	TD PD Diagnostic Summary.....	142
12.5.4	Further action applied	142
12.5.5	Further happening	143
12.5.6	Investigation.....	143
12.5.7	Conclusion & recommendation	145
12.5.8	Result of Case Study.....	145
13	References	146
13.1	Bibliography	146
13.2	Table of Figures and Tables	147

Testing and Diagnostics

on Medium Voltage Underground Cable Networks based on VLF

1 Introduction

Inspection and commissioning of newly installed HV equipment especially for the power transmission and distribution network is an important procedure to ensure the reliability and performance of the power supply. Since many years HV DC and HV AC testing at power frequency under laboratory and field conditions have been reliable tools for insulation assessment.

Beyond recent development in the international standards, new methods and testing frequencies were added to these new standards like VLF – rather than power frequency. The assessment of ageing and preventing damages of medium and high voltage underground cable system is highly important for the utilities today. Due to the quality of the power distribution network and the high cost of increasing demand of reliability in the power supply, the underground cable system needs more performance testing and control. [1]

Technologies and standards have been developing during the last decade. Numerous technical papers have been presented on international platforms and conferences. Physical and chemical procedures around and about medium voltage underground cables and its accessories have been elaborated and analysed into very detail. Technologies that can understand and measure the phenomenas have been developed and evaluated.

Today, an interested engineer or operations manager can read hundreds of articles and detailed papers but it is hard to keep the overview.

This book shall help maintenance engineers, operation managers and all other interested experts to keep to focus on a selection of documents that are summarized here. Accordingly, several sections have been taken from papers directly and cited accordingly.

2 VLF Testing

2.1 Why should VLF be used for testing of MV underground cables?

For insulation coordination it is a need to test the withstand strength of equipment with a stress similar to the stress in operation. Diagnostic procedures are more or less free in the stress of the insulation. Requirements are first not to damage proper insulation and second to achieve a sufficient recognition of the status. DC testing conflicts both requirements when testing PE / XLPE insulated power cables.

Very Low Frequency test voltages have first been introduced for testing high power generators. Recognizing the danger of DC testing of PE/XLPE cables, VLF was one of the possible alternatives. First VLF was used as a possible withstand at typically $3U_0$ for one hour. Later dissipation factor (DF) measurement ($\tan \delta$) and partial discharge (PD) measurements have been introduced as diagnostic tools. [2]

2.1.1 Withstand Test with VLF

VLF withstand tests are successfully introduced and standardized for power cables [VDE], experience e.g. described in [Moh, 2003]. According to [Goc, 2000], fig. 1 the withstand voltage of non pre damaged insulation at VLF (0.1 Hz) is two times higher compared to PLF (50 Hz). I.e. even if higher test voltages are used, non pre-damaged parts of the insulation are not endangered during these VLF tests. [2], [3]

Several reasons of advantage can be mentioned to test the underground cable system network with VLF.

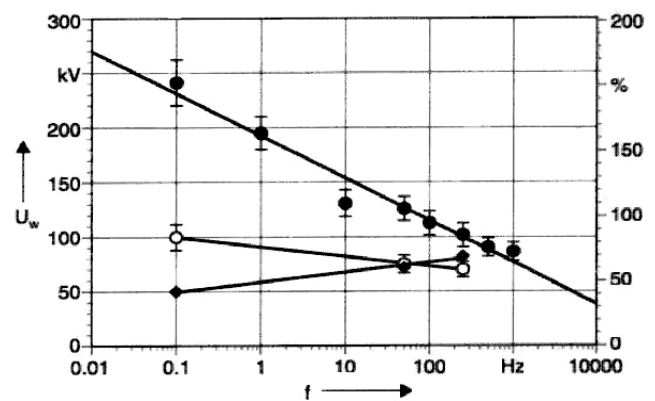

Figure 1 Withstand voltage as a function of the frequency for model cables without and with mechanical damages [Goc, 2000]: [3]
 ● Withstand voltage without mechanical damage,
 ○ Withstand voltage with mechanical damage,
 ◆ Ratio between withstand voltage with and without mechanical damage [1]

2.1.2 Why DC test may not be used for XLPE cables?

Many power utilities had been using DC voltage for on-site testing of cables. The same practice was retained when XLPE cables were introduced into the system about 20 years ago. However recent study on cable failures in developed utilities revealed the fact that this traditional method of cable testing, which is relatively reliable on PILC cables, is ineffective in detecting hidden defects in XLPE insulation. It was found that DC voltage testing could induce trapped space charges in the polymeric material, which are detrimental to the dielectric strength of the cables. After successfully passing the DC voltage, these cables would breakdown again shortly after being re-energized. Similar behavioral pattern was also observed in the medium voltage (MV) cable failures. [4]

Space charges can be visualized by distributing the voltage distribution during a DC test between the sheath and core over the distance of insulation. The voltage distribution indicates that voids that are acting as small capacitors at particular positions can store certain energy. Depending on its position along the diameter the voltage can reach quite high after several minutes of DC test. After the test has been completed, the core is discharged and kept grounded. The voltage distribution along the insulation will remain for a certain time. Voids that are charged may keep their charge due to the surrounding highly insulating XLPE material.

Cables that are switched on after a successful DC test may face that those locations with voids will receive overstress and might fail soon after the switching on sequence.

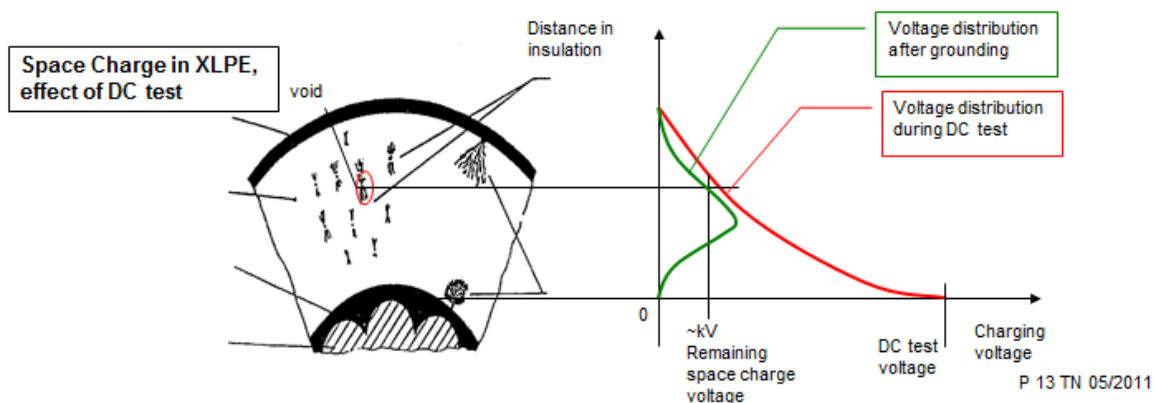

Figure 2 Space Charges in voids of XLPE during DC test [5]

2.1.3 Requirements for Cable Testing and Standards

New standards, like IEC 60060-3 – 2006, defines the VLF voltage source as an adequate waveform for HV field testing; it represents today's state of the art of different HV excitation voltage sources. In fact, the VLF cable field tests, based on the standard mentioned before has become a worldwide accepted field test and diagnostic **method for commissioning and maintenance work** within medium and high voltage applications.

Furthermore the given standards are minimum requirements.

The operators are free to choose higher levels of criteria than the standard requirements like IEC 60060-3, IEEE STD 400.2 or VDE 60620 HD S1.

Specification according to a standard motivates the suppliers and the users of underground cable systems to improve the system reliability. Regular diagnostic controls protect the user of incipient failures on underground distribution systems. By any reason of faults, damages related to liability or guarantee procedures, the user or supplier is protected (insured) if the cause of failure can be analysed and localized in a non-destructive way. [1]

2.1.4 Technical reasons using VLF

- Weight and volume of test equipment
- Mobility for field application
- Higher efficiency in finding insulation defects
- Higher sensitivity and precision on TD measurement compared to power frequency or oscillating wave
- Diagnostic efficiency, using truesinus® HV source for PD measurements
- Fault distance monitoring during commissioning and proof tests with PD monitoring
- **VLF testing is far more effective than DC**
- **DC may produce space charges in the dry cable insulation with long term damage to the cable [1]**

2.1.5 Commercial reasons using VLF

In respect of maintenance strategies the following facts are to be considered:

- Power consumption (may cause very high cost)
- Event based maintenance (high cost)
- Cost of repair – refurbishment (low cost) [1]

2.1.6 General strategic reasons using VLF

- Improve wide scale system reliability
- Reduce hours lost/user/per year
- Condition based maintenance (medium high cost)
- Preventive maintenance (very high cost)
- Replacement, decisions on partial replacements
- Reliable system for life time considerations and system assessment data evaluation [1]

2.2 Standards for high voltage field testing for HV cables

In the mid-1980s, alternative field test methods were presented for underground medium voltage cable by means of solid dielectric using very low frequency in the range of 0.01 to 1 Hz. Besides power frequency, also VLF test can be used alternatively. Large field and laboratory tests have clearly proofed not only practicability but also benefits of the new testing equipment. The most common VLF high voltage waveform worldwide is **sinusoidal according to IEC 60060-3**.

VLF testing started to be defined in standardization committees in 1996. The European Harmonization Committee CENELEC released the first standard HD 620 S1 field testing for MV cables, in the range of 6 kV to 36 kV. In 2004 the IEEE published a first field testing guide IEEE STD 400.2-2004® for VLF field testing on high voltage MV cables. [1]

In 2014, the CENELEC HD 620 S1 has finally been implemented in the new IEC 60502 standard. Now VLF testing has been officially named to be the recommended testing standard especially for extruded XLPE underground cables. **Monitored Withstand Test is further mentioned to be a recommended approach for advanced VLF test.**

The overall field guide IEEE 400-2012 for application of field tests explains the different available technologies for testing and evaluation of the insulation of shielded power cable systems rated 5kV and above. VLF testing in particular is described in the technology specific field guide IEEE400.2 with latest version of 2013.

The latest IEC 60060-3 standard, which has been released in 2004, is dealing with test equipment especially for on-site testing and includes VLF test equipment. IEC 60060 standards are so called horizontal standards. This means their validity covers all components (such as cables, transformers, rotating machines, etc.) and all voltage ranges above 1 kV. As a horizontal standard IEC 60060-3 does not define values. The test levels are left to the component relevant standards (such as IEC 60502-2014, CENELEC HD 620 and 621, VDE 0267 or IEEE 400.2 for cables).

Therefore, the diagnostic approach with VLF can be describes as **“Testing and Diagnostic according to standards!”**

The most important new items of IEC 60060-3 are:

- VLF test equipment is included
- Accuracy levels for test voltages on site are given
- Record of performance for on-site test equipment is introduced
- Performance test and performance check is being defined for on-site test equipment

The benefit for the customers is to get and maintain reliable on site test equipment of certified accuracy and performance. The values for accuracies for on-site equipment are adapted to the needs and the cost structure of on-site equipment. [6]

2.3 Testing and Diagnostic according to standards

Testing Standards for Underground Power Cable Networks 6kV – 500kV

	Medium Voltage Cables <i>Mittelspannungskabel</i> 6 – 69kV			
	IEC 60502-2 2014	CENELEC HD 620 – 1996	IEEE400.2- 2013	Example Utility Standard <i>Bsp.</i> <i>EVU-Richtlinien</i>
Commissioning testing <i>Abnahmeprüfung</i>	3xU _o 15min - VLF 0.1Hz - ACRT 15min, 20-300Hz - no-load test, 24h, 1.0U _o 50/60Hz - TD/PD recommended - 4xU _o , 15min, DC	2.0xU _o 60min - 45-60Hz 3xU _o 60min - VLF 0.1Hz Oversheath testing <i>Mantelprüfung</i>	Testing 2.2 – 2.8U _o 15 – 60min - VLF - VLF MWT (TD / PD) Diagnostic max. 2.0U _o - VLF TD - VLF PD	Testing 3xU _o 30/60min - VLF 0.1Hz 3xU _o 5min - VLF + PD
Maintenance testing <i>Instandhaltung</i>			Testing 1.8 – 2.2 15 – 60min - VLF - VLF MWT Diagnostic Max. 1.5U _o - VLF TD - VLF PD	Testing 3xU _o 10min VLF 0.1Hz Diagnostic Max. 2.0U _o - VLF TD - VLF PD

Table 1 overview testing and diagnostic standards for MV cables

	High Voltage Cables <i>Hochspannungskabel</i> 30-150kV		Extra High Voltage Cables <i>Höchstspannungskabel</i> 150kV – 500kV	
	IEC 60840	IEC 60229 Sheath test / <i>Mantelprüfung</i>	IEC 62067 -2000	IEC 60229 Sheath test / <i>Mantelprüfung</i>
Commissioning testing <i>Abnahmeprüfung</i>	1.7 -2.0U _o -ACRT 60 min, 20-300Hz -no-load test 24h, 1.0U _o 50/60Hz Oversheath testing <i>Mantelprüfung</i>	4kV/mm max. 10kV 1min	1.1– 1.7U _o - ACRT 1h, 20-300Hz -no-load test 24h, 1.0U _o 50/60Hz	4kV/mm max. 10kV 1min

Table 2 overview testing and diagnostic standards for HV and EHV cables

2.3.1 IEC 60060-3

IEC 60060-3 standard was released in 2004. It is considered as horizontal standard that defines the characteristic and requirements for VLF testing voltage.

<p>9.3 Test voltage</p> <p>9.3.1 Voltage wave shape</p> <p>The test voltage should be an alternating voltage having a frequency between 0,01 Hz and 1 Hz.</p> <p>NOTE With respect to the wide frequency range the relevant Technical Committee should specify the frequency dependent on the test object, the test duration and the voltage value.</p> <p>Sinusoidal VLF voltage waveshape shall approximate a sinusoid with both half-cycles closely alike. The result of a high voltage test is thought to be unaffected by small deviations from a sinusoid if the ratio of the peak to r.m.s values is within $\sqrt{2} \pm 15\%$.</p> <p>NOTE If the ratio of peak to r.m.s values is not within $\sqrt{2} \pm 5\%$, it should be verified that positive and negative peaks do not differ by more than 2 %.</p> <p>Rectangular VLF voltage wave shape shall approximate a rectangular wave with both half-cycles closely alike. The polarity change should be controlled to avoid overvoltages caused by transients. The ratio of peak to r.m.s. value shall be within $1.0 \pm 5\%$.</p> <p>9.3.2 Tolerance</p> <p>The measured value of the test voltage shall be within $\pm 5\%$ of the specified value unless otherwise specified by the relevant Technical Committee.</p>
--

Figure 3 Extract of IEC60060-3 definition of maximum distortion value of $\pm 5\%$ [7]

Definition acc. to IEC 60060-3:

The VLF wave form is defined as an alternating voltage with a frequency of 0.01Hz to 1Hz. The waveform can vary from sinusoidal to rectangular. The tolerance of the measured value shall be within $\pm 5\%$. This value is limiting the acceptable distortion value.

2.3.2 IEC 60502-2 Edition 3.0 / 2014-02



IEC 60502-2

Edition 3.0 2014-02

INTERNATIONAL STANDARD

**Power cables with extruded insulation and their accessories for rated voltages from 1 kV ($U_m = 1,2$ kV) up to 30 kV ($U_m = 36$ kV) –
Part 2: Cables for rated voltages from 6 kV ($U_m = 7,2$ kV) up to 30 kV ($U_m = 36$ kV)**

2 Normative references

The following documents, in whole or in part, are normatively referenced in this document and are indispensable for its application. For dated references, only the edition cited applies. For undated references, the latest edition of the referenced document (including any amendments) applies.

IEC 60038, *IEC standard voltages*

IEC 60060-1, *High-voltage test techniques – Part 1: General definitions and test requirements*

IEC 60060-3, *High-voltage test techniques – Part 3: Definitions and requirements for on-site testing*

IEC 60183, *Guide to the selection of high-voltage cables*

IEC 60228, *Conductors of insulated cables*

IEC 60229:2007, *Tests on cable oversheaths which have a special protective function and are applied by extrusion*

IEC 60230, *Impulse tests on cables and their accessories*

IEC 60287-3-1, *Electric cables – Calculation of the current rating – Part 3: Sections on operating conditions – Section 1: Reference operating conditions and selection of cable type*

IEC 60332-1-2, *Tests on electric and optical fibre cables under fire conditions – Part 1-2: Test for vertical flame propagation for a single insulated wire or cable – Procedure for 1 kW pre-mixed flame*

IEC 60811 (all parts), *Electric and optical fibre cables – Test methods for non-metallic materials*

Figure 4 Extract IEC 60502-2, page 12, [8]

IEC 60060-3 ... describes the characteristic of the voltage shape applied
IEC 60229:2007 ... standard for cable sheath testing

20.2 DC voltage test of the oversheath

The voltage level and duration specified in Clause 5 of IEC 60229:2007 shall be applied between each metal sheath or metal screen and the ground.

For the test to be effective, it is necessary that the ground makes good contact with all of the outer surface of the oversheath. A conductive layer on the oversheath can assist in this respect.

20.3 Insulation test

20.3.1 AC testing

By agreement between the purchaser and the contractor, an a.c. voltage test in accordance with IEC 60060-3 and in accordance with item a), b) or c) as below may be used:

- a) test for 15 min with the phase-to-phase voltage U , at a frequency between 20 Hz to 300 Hz shall be applied between the conductor and the metal screen/sheath;
- b) test for 24 h with the normal rated voltage U_0 of the system;
- c) test for 15 min with the RMS rated voltage value of $3 U_0$ at a frequency of 0,1 Hz applied between the conductor and the metal screen/sheath.

NOTE 1 During the a.c. test, $\tan \delta$ and/or partial discharge may be monitored.

NOTE 2 For installations which have been in use, lower voltages and/or shorter durations may be used. Values should be negotiated, taking into account the age, environment, history of breakdowns and the purpose of carrying out the test.

[8, p. 43]

With the new version of IEC 60502, item c) VLF testing has been added. Note 1 applies for VLF testing. Monitoring of TD and PD may be done. According to IEEE400-2012 this is described as monitored withstand testing.

2.3.3 CENELEC HD 620 (S1), VDE 0267 HD S1 (1996)

The CENELEC Harmonization Document HD 620 S1, is defined as pre-version of the internationally released IEC standard. The harmonization document has been released already in 1996. In Europe, this harmonization document is already used as a VDE standard VDE 0267 HD 620S1 (1996) and is handled as common standard for Cable After Laying Testing.

It is expected to be released as IEC Standard in short term world-wide.

Page 5-C-19
HD 620 S1:1996
Part 5 Section C

3. Test requirements (concluded)

5. Recommended tests after installation, if required

	Test	Requirements	Test method
1.	Voltage test on insulation ^{1) 2)}		
1.1	a.c. test voltage 45 to 65 Hz - test voltage (r.m.s) $2U_0$ - test duration 60 min	no breakdown	
	alternatively:		
1.2	a.c. test voltage 0.1Hz - test voltage (r.m.s) $3U_0$ - test duration 60 min	no breakdown	

Figure 5 Extract of CENELEC HD 620 (S1) or VDE 0267 HD 620 S1 (1996) [9]

2.3.4 IEEE STD. 400.2

There is a controversy concerning the testing voltage levels due to the unknown ageing level of the cable insulation and possible damage and degradation [6]. Therefore, a testing standard with $3U_0$ is recommended to apply **only for commissioning and after laying tests**. [1]

To secure the distribution network on a long term view, reliability and performance tests using VLF HV field tests related to the recommended standards can avoid incipient faults in the URD (Underground Distribution) system [3,4]. Today adequate portable VLF test equipment for field use are available on the market. Latest research findings regarding power frequency, VLF testing and diagnostic results support the idea of Very Low Frequency. Newly designed state of the art VLF HV sources use solid state high precision amplifiers.

It's a technique to produce a true-sinusoidal output signal and allowing high precision partial discharge and harmonic free HV sources to secure TD and PD requirements for precise diagnostic measurements [10,11]. [1]

IEEE 400.2-2001 / IEEE 400.2-2004 / IEEE400.2/D12 Jan 2012 / IEEE400.2-2013

The IEEE committee basically is a committee of experts of power utilities, universities as well as equipment manufacturers. Together, guidelines for practical application of testing methods had been summarized. These guidelines give a recommendation to apply different test voltage levels for different tests. The applications are categorized in Installation Test, Acceptance Test and Maintenance Test.

1.2 Purpose

This guide is intended to provide troubleshooting and testing personnel with information to test shielded medium- and high-voltage cable systems rated 5 kV through 69 kV using VLF ac techniques.

Figure 6 Definition of the purpose of IEEE400.2-2013, [10, p. 2]

According to IEEE400.2-2013, these tests are defined as following: [10, pp. 3,4]

Installation test: A field test conducted after cable installation but before jointing (splicing), terminating or energizing. The test is intended to detect shipping, storage, or installation damage. It should be noted that temporary terminations may need to be added to the cable to successfully complete this test, particularly for cables rated above 35 kV.

Acceptance test: A field test made after cable system installation, including terminations and joints, but before the cable system is placed in normal service. The test is intended to detect installation damage and to show any gross defects or errors in installation of other system components.

Maintenance test: A field test made during the operating life of a cable system. It is intended to detect deterioration and to check the serviceability of the system.

These test voltage levels are defined differently for cosine-rectangular waveform (defined with peak value) and sinusoidal waveform (defined with RMS value). The Guide for Field Testing of Shielded Power Cable Systems Using Very Low Frequency (VLF) [10] defines test levels related to Peak or RMS voltages.

Table 3: VLF withstand test voltages for sinusoidal and cosine-rectangular waveforms¹

Waveform	Cable System Rating (Phase to Phase) [kV]	Installation (Phase to Ground)		Acceptance (Phase to Ground)		Maintenance ² (Phase to Ground)	
		[kV rms]	[kV peak]	[kV rms]	[kV peak]	[kV rms]	[kV peak]
Sinusoidal	5	9	13	10	14	7	10
	8	11	16	13	18	10	14
	15	19	27	21	30	16	22
	20	24 ³	34 ³	26	37	20	28
	25	29 ³	41 ³	32	45	24 ³	34 ³
	28	32	45	36 ³	51 ³	27	38
	30	34	48	38	54	29 ³	41 ³
	35	39	55	44	62	33	47
	46	51	72	57	81	43	61
	69	75	106	84	119	63	89

Waveform	Cable System Rating (Phase to Phase) [kV]	Installation (Phase to Ground)		Acceptance (Phase to Ground)		Maintenance ² (Phase to Ground)	
		[kV rms]	[kV peak]	[kV rms]	[kV peak]	[kV rms]	[kV peak]
Cosine Rectangular	5	13	13	14	14	10	10
	8	16	16	18	18	14	14
	15	27	27	30	30	22	22
	20	34	34	37	37	28	28
	25	41	41	45	45	34	34
	28	45	45	51	51	38	38
	30	48	48	54	54	41	41
	35	55	55	62	62	47	47
	46	72	72	81	81	61	61
	69	106	106	119	119	89	89

Note 1: If the operating voltage is a voltage class lower than the rated voltage of the cable, it's recommended that the maintenance test voltages should be those corresponding to the operating voltage class unless it is known that the accessories are the same class as the cable, in which case the test voltages should be those corresponding to the rated voltage.

Note 2: The maintenance voltage is about 75% of the acceptance test voltage magnitude.

Note 3: Some existing test sets have a maximum voltage that is up to 2 kV below the values listed in the Table. These test sets are acceptable to be used.

*VLF ac voltage testing methods utilize AC signals at frequencies in the range of 0.01 Hz to 1 Hz. The most commonly used, commercially available **VLF ac voltage test frequency is 0.1 Hz**. VLF ac voltage test voltages with cosine-rectangular and the sinusoidal wave shapes are*

most commonly used. While other wave shapes are available for testing of cable systems, recommended test voltage levels have not been established.

Other commercially available frequencies are in the range of 0.001 Hz up to 1 Hz. Frequencies lower than 0.1 Hz may be useful for diagnosing cable systems where the length of the cable system exceeds the limitations of the test equipment at 0.1 Hz. However, if tests at frequencies below 0.1 Hz are carried out, consideration should be given to extending the test duration to ensure that there are a sufficient number of cycles to cause breakdown if an electrical tree is initiated.

Some comments on reliability can be made based on data collected from approximately 16,000 km (10,000 miles) of cable systems since 2000 from several North American utilities. VLF withstand tests can be performed on a large range of cable lengths (~75 m to ~4.5 km). Thus the risk of failure on test can be considered on two levels as shown in Table 4 of [11]:

1. risk of failure on test as a function of cable length.
2. risk of failure on test for a specific length of cable, e.g., 300 m.

Figure 7 Table 3, of IEEE400.2-2013, [10, p. 11]

Practical experience of power utilities following these recommendations confirmed the published technical papers showing case studies.

Diagnostic is today's alternative solution!

Without any unnecessary pressure test, all performance details can be analysed by TD Tangens Delta Dissipation Factor measurement (TD or DF) and PD Partial Discharge Diagnostic.

Beside the recommendation of test voltage levels, the since the year 2001 "IEEE 400.2-2001 Guide for Field testing of Power cables" publishes recommended evaluation criteria for TanDelta dissipation factor values for XLPE cables. [12, p. 23]. In 2013 "IEEE4002.-2013 Guide for Filed testing of Shielded Power Cable Systems" the practical experience over a decade was summarized in new criteria values.

Figure 8 Extract of IEEE 400.2-2001, 9.3 Method of TD evaluations [12, p. 23]

The new version of the field guide “IEEE400.2-2013” summarized the experience, that was collected over the past decade with the definition of different evaluation criteria for PE, XLPE, TRXLPE, EPRs and paper-type insulations. A differentiation on diagnostic evaluation criteria between new and aged cables is defined. In addition, the criteria for TD evaluation have been extended with the value of tangent delta stability (VLF-TDTS).

5.4 Tangent delta/differential tangent delta/tangent delta stability/leakage current/harmonic loss current tests with VLF sinusoidal waveform

5.4.1 Measurement and equipment

VLF Tangent delta, differential tangent delta, tangent delta stability, leakage current, and loss current harmonics measurements may be used to monitor aging and deterioration of cable systems (Werelius [B35]). However, tangent delta (VLF-TD), differential tangent delta (VLF-DTD), and tangent delta stability (VLF-TDTS) measurements are the most commonly used methods in the field. A correlation between an increasing 0.1 Hz tangent delta and a decreasing insulation breakdown voltage level at power frequency has been reported (Bach, Kalkner, and Oldehoff [B3]; Hvidsten, et al. [B24]; Hernandez-Mejía, et al. [B21]) for PE and cross linked polyethylene (XLPE) cables. The 0.1 Hz tangent delta, differential tangent delta, and tangent delta stability are mainly determined by degradation of the cable insulation (water-trees), corroding metallic shields, insulation moisture, and degraded accessories. The measurement of the tangent delta, differential tangent delta and/or tangent delta stability with a 0.1 Hz sinusoidal waveform offer comparative assessment of the aging of PE, XLPE, TRXLPE, EPRs, and paper-type insulations and can be used as a diagnostic test. The test results permit differentiating between new, defective, and highly degraded cable systems (Baur, Mohaupt, and Schlick, [B6]; Hernandez-Mejía, et al. [B21]; Hampton, et al. [B20]; Hampton and Patterson [B18]).

Cable systems can be tested in preventive maintenance programs and returned to service after testing. The measurements at VLF can be used to make decisions on cable/accessory replacement, cable rejuvenation, or repair expenditures.

Figure 9 Extract of IEEE 400.2-2013, 5.4 VLF-TD, VLF-DTD, VLF-TDTS with VLF sinusoidal waveform [10, p. 15]

Table 2—Usefulness of VLF ac voltage testing methods for selected cable and/or insulation conditions

Cable condition	Diagnostic test methods				
	Simple withstand test methods	VLF-MW	VLF-TD VLF-DTD VLF-TDTS VLF-DS	VLF-PD	VLF-LC VLF-LCH
Cables with metallic shield corrosion	Acceptable	Acceptable	Acceptable	Poor (see Note 1)	Poor
Extensive water treeing	Acceptable	Good	Good	Poor (See Note 2)	Good
Few large defects or few localized electrical trees	Good	Acceptable/Good (see Note 3)	Acceptable/Good (see Note 2)	Acceptable/Good	Acceptable/Good (see Note 3)
Defective splices and terminations	Acceptable/ Good (see Note 4)	Acceptable/Good (see Note 3)	Acceptable (see Note 3)	Acceptable (see Note 2)	Acceptable (see Note 3)
Mixed insulation (extruded and/or laminated)	Good	Good (see Note 4)	Poor/Good (see Note 4)	Good (See Note 5)	Poor/Good (see Note 4)

Note 1: PD testing can be less sensitive on aged taped shielded cables due to corrosion of the shield overlaps and the resulting changes of current distribution within the tape.

Note 2: PDs are detectable only if there are one or more active electrical trees or tracking sites or there are voids in the cable insulation or accessories. Moreover it should be noted that PD inception conditions at VLF can be different to those at other frequencies.

Note 3: Supplemental testing is recommended to distinguish a severe localized defect from general overall deterioration.

Note 4. As this test technique measures the average of all the insulations under test, supplemental testing is recommended to measure individual sections of the insulation. VLF-TD, VLF-DTD, VLF-TDTS, VLF-DS or non VLF techniques can be used to differentiate mixed cable insulations. If individual sections cannot be measured, the usefulness may be poor.

Note 5. The different propagation characteristics of the various cable sections (different sizes and/or insulations) may make localisation difficult.

Table 3, Table 2, page 9 of IEEE400.2,2013, [10, p. 9] Usefulness of VLF TD PD Testing and Diagnostic methods

3 Monitored Withstand Test (MWT)

NEETRAC has been working on extensive practical research projects for the past years. Among the latest projects, the investigation of the **dielectric parameters during the Simple Withstand Test** has been carried out.

The National Electric Energy Testing, Research and Applications Centre (NEETRAC) is a non-profit, member supported electric energy research, development and testing centre, housed in the Georgia Institute of Technology's

Utilities	
American Electric Power	FirstEnergy
Ameren	FPL
BC Hydro	Hydro Quebec
CenterPoint Energy	NRECA
Consolidated Edison	Pacific Gas & Electric
Dominion	PacifiCorp
Duke Energy	SCE&G
EPRI	Southern California
Exelon	Southern Company

Figure 10 participating members in the NEETRAC research organization [13]

Stating the interpretation on the practical experience of conventional withstand tests, the corporate authors of the paper “First Practical Utility Implementations of Monitored Withstand Diagnostic in the USA” [13] have pointed out well known side effects of a conventional withstand test as per following chapter.

“Proof or withstand tests have been used for a very long time in the cable industry and find their origins in the well-known routine tests carried out in accessories and cable factories. Although this test continues to serve the industry well, when a simple Withstand is implemented in the field users continue to be concerned by three issues:

- There is no way to estimate the quality of the cable system, and hence the risk of failure, prior to the application of the proof voltage.
- There is no way to adjust the extent of the test (either be decreasing or increasing) according to the quality of the cable system.
- There is no way to judge the quality of the pass, should the cable system support the proof voltage i.e. was the pass a good one or a marginal one. “

It had been suggested that if a diagnostic parameter, such as **dielectric loss, leakage or partial discharge, were monitored during a proof test then all of the three issues noted above might be addressed.** Consequently since 2008 the authors have been conducting Monitored Withstand Tests (MWT) on utility systems using very low frequency (VLF) waveforms to assess the practicality of the initial hypothesis. Experience has shown that the Monitored Withstand whether using Partial Discharge or Dielectric Loss does bring considerable and useful information to the utility engineers.

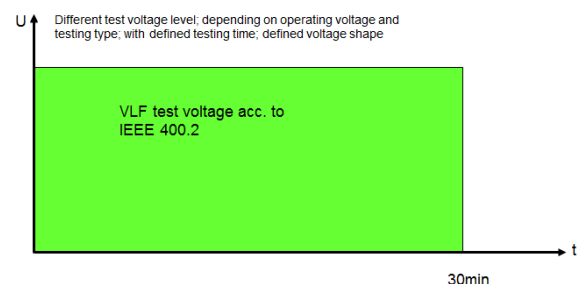

Figure 11 Simple VLF Test acc. to IEEE400.2 [10]

One of the drawbacks of Simple Withstand tests is that there is no straightforward way to estimate the “Pass” margin – once a test (say 30min at 2 Uo) is completed, it is impossible to differentiate among those passing segments. That is, it is impossible to distinguish the segments that would survive 120min from those that would have only survived 40min. Thus, it is useful to employ the concept of a Monitored Withstand Test whereby a dielectric property or discharge characteristic is monitored to provide additional data.

There are four ways these data are useful in making decision during the test.

1. Provide an estimate of the “Pass” margin.
2. Enable a utility to stop a test after a short time if the monitored property appeared close to imminent failure on test, thereby allowing the required remediation work to take place at a convenient (lowest cost) time.
3. Enable a utility to stop a test early if the monitored property provided definitive evidence of good performance, thereby increasing the number of tests that could be completed and improving the overall efficiency of field test.
4. Enable a utility to extend a test if the monitored property provided indications that the “Pass” margin was not sufficient large, thereby focusing test resources on sections that present the most concern.

In a Simple Withstand test, the applied voltage is raised to prescribed level, usually 1.5 to 2.5 times the nominal circuit operating voltage for a prescribed time. The purpose is to cause weak points in the circuit to fail during the elevated voltage application when the circuit is to supplying customers and when the available energy (which may be related to the safety risk) is considerably lower. Testing occurs at a time when the impact of a failure (if it occurs) is low and repairs can be made quickly and most effectively.

When performing a Monitored Withstand test, a dielectric or discharge property is monitored during the withstand period. The data and interpretation are available at real time during the test so that the decisions outlined above might be made. The dielectric or discharge values monitored are similar to those described in earlier sections. However, their implementation and interpretation differs due to the requirement of a fixed voltage and a relatively long period of voltage application. Within these constraints, leakage current, Partial Discharge (magnitude and repetition rate) and Tan Delta (Stability and magnitude) might readily be used as monitors.

As described in [13] Figure 12 the schematic also includes a commonly implemented MWT sequence in a form of stepped increase in voltage and a hold period.

The critical part of the test is the measurement and interpretation during the withstand test. The step / ramp in voltage allows an evaluation before the start of the withstand test. This approach is valuable in that it enables the field engineers to assess the condition of the cable system before embarking on the MWT.

Weak cable conditions can be formed at a concentrated point (puncture) or a wider distributed general aging.

Accordingly, the only way in which a cable system may “Pass” a MWT is if there is no dielectric puncture and compliant information from the monitored property. Stable data (narrowly varying data) and low magnitude are the main criteria for assessment.

At this stage, it is instructive to examine the differences between the interpretations of Standard Dielectric Loss measurements compared to the assessment of the same property in a MWT.

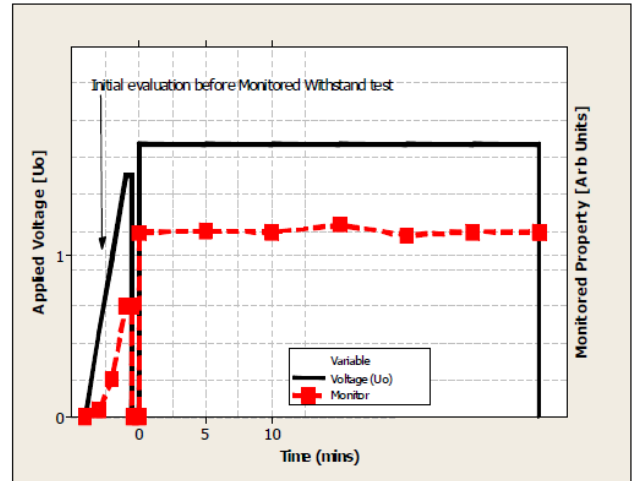

Figure 1: Schematic of a Monitored Withstand Test (black) with Optional Diagnostic Measurement (red)

The interpretation of the dielectric Loss Measurement shall focus on

- Stability within a voltage step assessed via the Standard Deviation of the TD measurement
- Tip Up (difference in the mean value of Tan Delta at two selected voltages) Tan Delta (mean value at U_0).

Figure 12 Schematic of a MWT (black) with Optional Diagnostic Measurement (red) [13]

When using the monitoring mode, the constant voltage employed does not permit the assessment of the Tip Up. However, this information can be available if a voltage ramp is used on the way of the withstand voltage level. Otherwise Tip-Up cannot form part of the standard hierarchy for Monitored Withstand.

Table 1 Comparison of Diagnostic Features (Tan Delta) for Step (incl pure Tan Delta tests) and Hold Portions of Monitored Withstand tests

	Voltage Step Portion & Tan Delta Assessment	Voltage Hold (Withstand - Constant Voltage) Portion
Stability (Standard Deviation)	over 6 to 12 measurements at U_0	extended time at IEEE400.2 voltage level
Voltage Dependence of Tan Delta (Tip Up)	between $1.5U_0$ & $0.5U_0$	-
Tan Delta (Mean)	over 6 to 12 measurements at U_0	extended time at IEEE400.2 voltage level
Change in Tan Delta with time	-	between 0 & 10 minutes

There are similar issues with the mean TanDelta. A mean Tan Delta can be computed for the entire withstand period of the test. However, since this is a MWT, testing occurs at voltages above U_0 , the voltage commonly used for standard Tan Delta assessments.

Figure 13 Comparison of Diagnostic Features for Step and Hold portions of MWT [10]

The concept of mean TanDelta is useful even at this higher voltage, but the critical values for assessment cannot be the same as those used for Tan Delta at U_0 . In fact, these values are likely to be higher than those used for the standard TanDelta assessment.

Table 2: Criteria for Condition Assessment Criteria of Paper Insulations (PILC) for Dielectric Loss and Monitored Withstand Modes

Condition Assessment	Tan δ Stability Measured @ U_0 [E-3] (Dielectric Loss Mode)	Tan δ Stability Measured @ IEEE Std. 400.2 Withstand levels [E-3] (Monitored Withstand Mode)
No Action Required	<0.3	<1.4
Further Study Advised	0.3 to 0.4	1.4 to 2.8
Action Required	>0.4	>2.8

In the approach detailed that is explained here, the stability has been assessed by considering the difference between initial and 10minute cases. 10 minutes has been chosen in that it is

Figure 14 Criteria for PILC cables [13]

sufficiently long to determine the underlying trend, yet sufficient time remains for the user to make an active decision on whether they wish to curtail the test at 15 minutes.

Generally the stability is the most useful parameter to assess the behaviour during the withstand test. Further it is stated that it is most important to note that the attributes are similar for the Ramp and Hold Phases but that the levels will be quite different due to the differences in the voltages and times of application.

Trend within the monitored period. These are likely to be categorical attributes:

- Flat,
- upward trend
- downward trend, etc.
- Stability within the monitored period
- Monitored property (mean value at withstand voltage)

In the context of a MWT the Condition Assessment (no action required, etc.) may also be used to determine real time guidance for the prosecution of the withstand test. The current recommended approach by the authors of [13] is to use the Condition Assessment to suggest how the IEEE 400.2 standard withstand test time might be modified by the cable system condition in respect of testing time:

The results of a VLF AC- sinusoidal MWT in which the TanDelta was monitored continuously for the 30minutes appears in Figure 16.

No Action Required	standard 30 minute test time may be reduced to 15 minutes
Further Study	retain standard 30 minutes
Action required	standard 30 minutes test time should be increased to 60minutes.

Table 3 Test Time Guidance and Condition Assessment for Monitored Withstand tests on MV cable systems

Test Time Guidance	Condition Assessment	Change in Tan Delta between 0 and 10 mins (E-3)		VLF-TD Stability (standard deviation) at Maintenance Level [10^{-3}]		Mean VLF-TD at Maintenance Level [10^{-3}]
PE-based Insulations (i.e. PE, XLPE, WTRXLPE)						
Reduced to 15 Mins	No Action Required	<0.25	and	<0.25	and	<5
Retain 30 Mins	Further Study Advised	>0.25 and <17	and	>0.25 and <6	and	>5 and <45
Extended to 60 Mins	Action Required	>17	or	>6	or	>45
Paper Insulations (i.e. PILC)						
Reduced to 15 Mins	No Action Required	<1.3	and	<0.7	and	<75
Retain 30 Mins	Further Study Advised	>0.13 and <4	and	>0.7 and <3.5	and	>75 and <135
Extended to 60 Mins	Action Required	>4	or	>3.5	or	>135

Figure 15 Test Time Guidance and Condition Assessment for MWT [13]

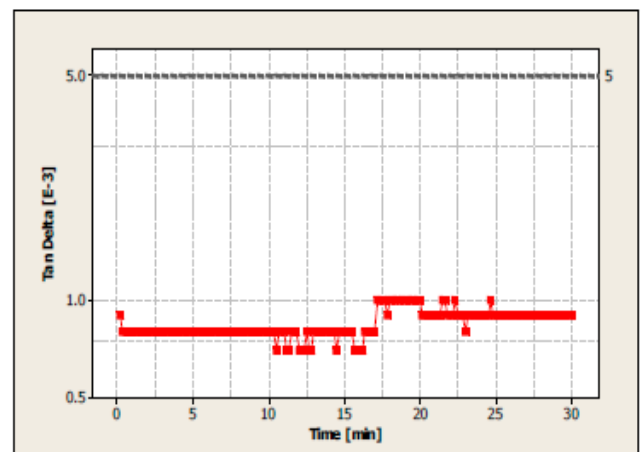

Figure 4: Tan delta Monitored Withstand Data on service aged XLPE cables

Figure 16 Tan Delta MWT on service aged XLPE cable [13]

When the criteria are applied to the example in Figure 16, the test results lead to the following assessment:

Tested segment did not have a dielectric puncture
change between 0 and 10 min: 0 E-3
Stability: 0.79 E-3
Tan Delta: 0.90 E-3

The Monitored Withstand assessment of this performance would likely be “No Action Required” and **test time may be reduced to 15minutes.**

In this case the utility chose not to reduce the test time even though it was possible in this case.

Summarizing, the challenges for the MWT is to find a way to take the available test data and make it available in a way to cover the wide range of situations that might develop in the field. [13]

The paper published in the 8th International Conference of Insulation Power Cables Jicable 2011 was the first official paper that addressed the critical questions behind the Simple Withstand test. The paper illustrates that practical approach that can be implemented by utilities.

In the last chapter of this work, several practical case studies are illustrating cases, where a MWT would have been helpful in order to recognize the marginal “Pass” of Simple Withstand test.

The utility mentioned in the case study welcomed the fundamental knowledge input offered by the paper [13]. The difficulties that are faced in the latter case studies are given by the complexity that cable networks can have. In dense cities with high population and highly developed metropolitan district, cable constellations have developed throughout the past 50 years. In the early 1980’s the first generation of XLPE cable had been implemented. Cable section of prior PILC cables had been replaced. In the later stage, the late 1980’s the second generation of XLPE was started to be implemented. Today cable constellations that contain old PILC cable section, 1st generation XLPE that are later called Water Tree Prone Cable Sections, 2nd generation XLPE and so on and so for. Due to the mixed constellation, evaluation criteria for Mixed Cables are very difficult to establish. Certain sections of water tree prone cables can sometimes not be identified as critical as they are over casted in the overall leakage condition of PILC sections. Water tree aging cannot be detected by PD measurement. Accordingly, in cases where the TD values show even relatively good condition, a potential threat due to highly service aged condition in a particular WTPC section would not become visible. With the understanding of these complex situations, the utility still utilizes a Simple Withstand test according to IEEE400.2. The minimum time of 15minutes is applied in order not to overstress in an unnecessary range in order to gain time for improvement works.

After implementation of the said maintenance procedure it was discovered that the strategy of 15min VLF test at 2Uo only guarantees at ~60% performance certainties. In other words, 40% of the tested cables have passed the Simple Withstand test with a marginal “Pass”. The extreme cases showed up as cable failure within a few hours after re-energizing.

The implementation of the monitored withstand test will allow to prevent on-load outages soon after re-energizing.

Summary – Monitored Withstand Test MWT

1. Stage: Ramp-up

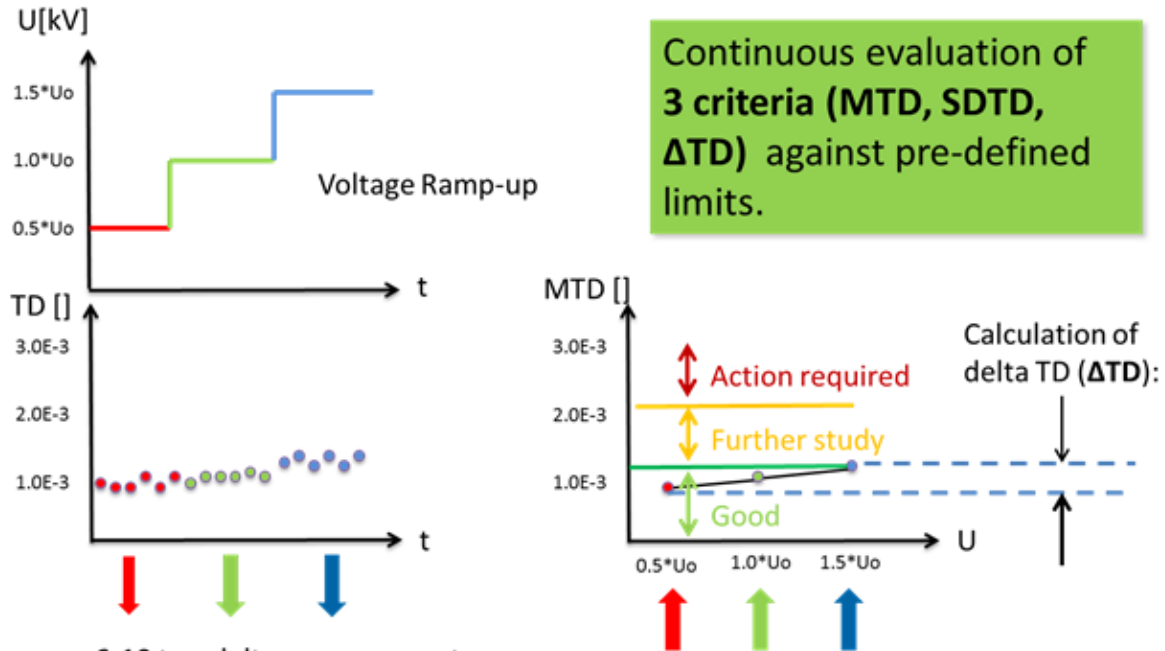

6-10 tan-delta measurements:

- Calculation of mean value (MTD) and plot the MTD versus test voltage
- Calculation of standard deviation (SDTD)

Figure 17, illustration of MWT-Ramp up stage

2. Stage: MWT (or hold)

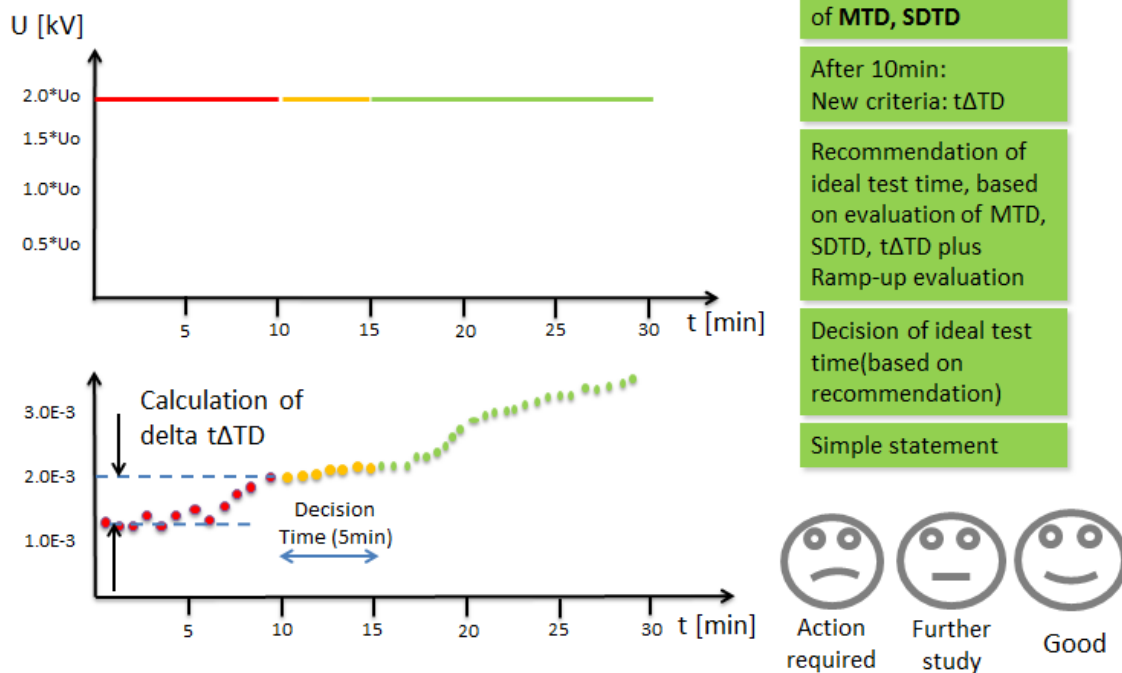

Figure 18, illustration of MWT / Hold stage

Example MWT 1: XLPE cable in good condition

Ramp-up curve

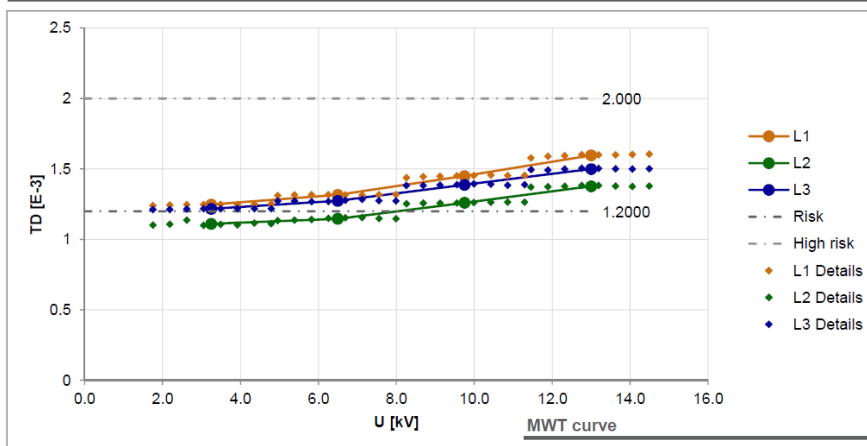

Figure 19, Ref. 8438CM, Ramp-up, XLPE stable condition

Ramp-up

- Low MTD
- Low SDTD
- Low Δ TD

MWT / Hold phase

- Low MTD
- Low $t\Delta$ TD
- Low SDTD

MWT curve

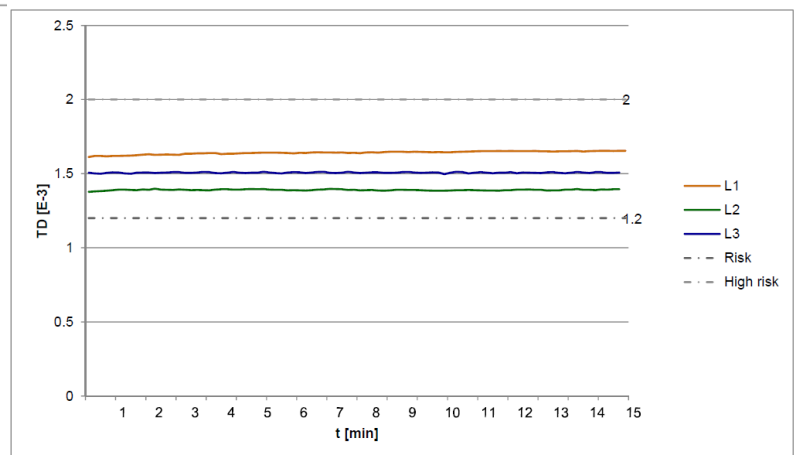

Figure 20, Ref. 8438CM, MWT/Hold phase, XLPE stable time stability

Example MWT 2: XLPE cable with influence of humidity

Ramp-up curve

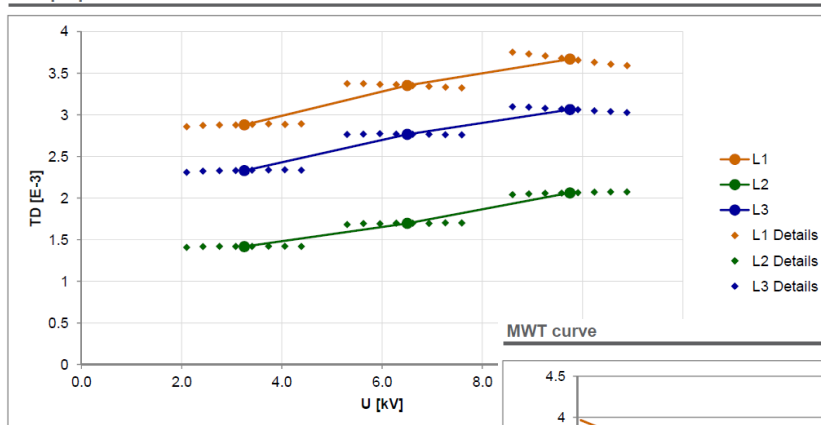

Figure 22, Ref. 12518CM, Ramp-up, decreasing trend

Ramp-up

- increased MTD
- increased SDTD
- decreasing Δ TD

MWT / Hold phase

- increased MTD
- high $t\Delta$ TD
- increased SDTD

MWT curve

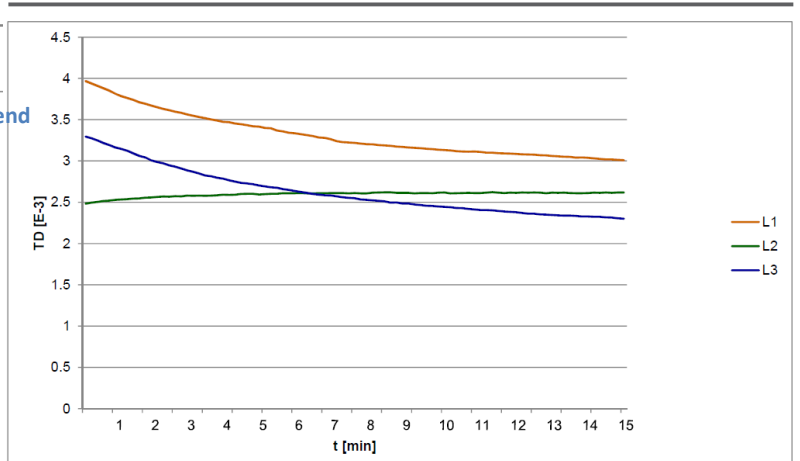

Figure 21, Ref. 12518CM, MWT/Hold phase, XLPE with decreasing $t\Delta$ TD

Example MWT 3: mixed cable with aged PILC, joint failure during test

Ramp-up curve

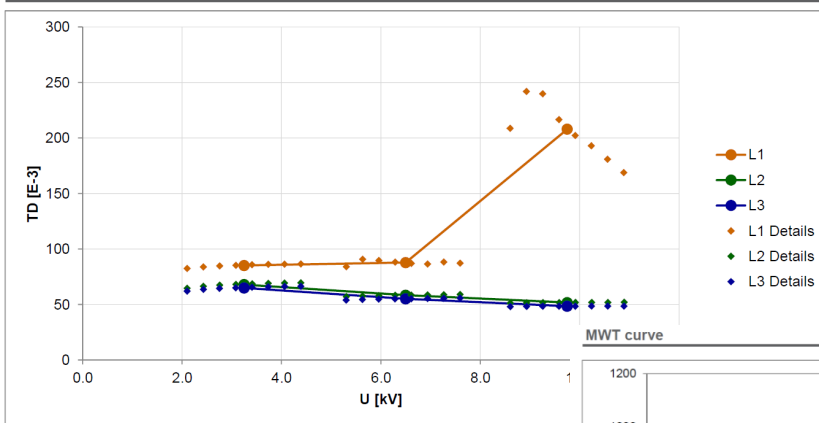

Figure 23; Ref. 3730-31, Ramp-up, tracking & moisture in L1, decreasing DTD, aged PILC

Ramp-up

- High MTD value, highly service aged PILC
- Very high MTD value in L1 at 1.5Uo
- increased SDTD
- decreasing Δ TD in L2, L3 .. indicates aged PILC

MWT / Hold phase

- stable MTD in L2 and L3
- decreasing $t\Delta$ TD in L1, indication of moisture in a joint
- breakdown after 4 minutes

MWT curve

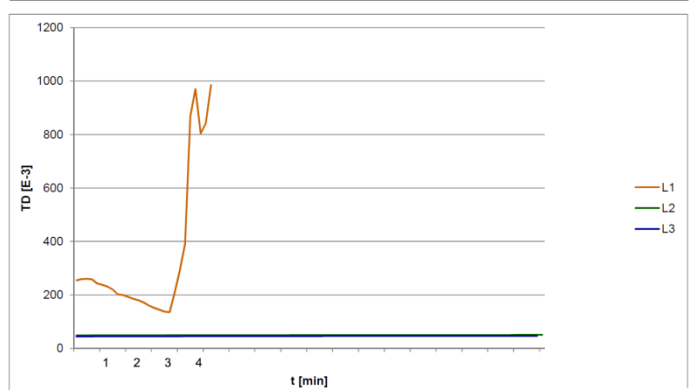

Figure 24; Ref. 3730-31, MWT / Hold phase, joint breakdown after 4 minutes

4 Practical recommendation for implementation of testing voltages in respect to the standards

After Laying Test			66kV cable	38kV U _o	33kV cable	19kV U _o	11kV cable	6.3kV U _o
CENELEC/ VDE HD 620 IEC 60502	3xU _o	60min	n.a.	3xU _o	57kVrect. 42.5kVrms	3.0xU _o 2.2xU _o	19kVrms	3xU _o
IEEE400.2- 2013	2- 3xU _o	15- 60min	n.a. (80kV)	2.1xU _o	40kVrms	2.1xU _o	18kVrms	2,8xU _o
MWT PD	2xU _o	15-60 min	42.5kV	1.1xU _o	40kVrms	2.1xU _o (max. 2.2U _o)	18kVrms	2,8xU _o

Maintenance								
VDE	3xU _o	10min	n.a.	3xU _o	57kVrect. 42.5kVrms	3.0xU _o 2.2xU _o	19kVrms	3xU _o
IEEE400.2	2- 3xU _o	15-60 min	60kVrect	1.6xU _o	30.4kVrms	1.6xU _o	14kVrms	2,2xU _o
MWT TD	Up to 2xU _o 0.5 – 1.0 – 1.5 ::2.0- 2.2U _o	15-60 min	Max. 42.5kVrms	Max. 1.1xU _o 0.5 -0.75 – 1.0 - 1.1xU _o	40.4kV (0.01- 0.1Hz)	2.0xU _o	14kVrms	2,2xU _o
TD Diagnostic	Up to 1,5xU _o	3 steps	Max. 42.5kVrms 1.0U _o =38kVrms	Recom- mended 0.5 -0.75 – 1.0U _o	30.3kVrms	1,5xU _o	9,5kVrms	1,5xU _o
PD Diagnostic	Up to 1,7xU _o	4 steps	Max. 42.5kVrms 1.1U _o = 42.5kVrms	Max. 1.1xU _o 0.5 -0.75 – 1.0 - ::1.1xU _o	33kVrms	1,7xU _o	11kVrms	1,7xU _o

Table 4 practical implementation of testing voltages in relation to the selected testing instrument Viola TD PD

Table based on **Viola TD PD** testing system

kVrms Truesinus®

kVrect ... peak value, rectangular

5 Discussion on Dielectric Response in XLPE/PILC Cables

A degraded insulation system shows increase of losses and decrease of dielectric strength. Dielectric response in its all appearance is a tool which can indicate the degradation and hence condition of electrical insulation of any kind. Water trees initiate and grow under electric field after water has penetrated into polymeric insulation. Water trees have long time been recognized as the most hazardous factor in life of XLPE distribution cables and the major cause of insulation failure.

Water trees increase the $\tan \delta$ and capacitance and decrease the electric strength of polymer-insulated cable. In addition, water and water trees modify leakage currents, DC absorption current, polarization and depolarization current as well as discharge voltage decay and return voltage. Field measurements of some of these parameters have proven to be a suitable means to detect degradation and presence of water trees. However, many measurement techniques have disadvantages, which have prevented their widespread application. For instance, $\tan \delta$ measurement gives overall condition of the cable system and not that of the deteriorated part of the cable. Also leakage current in joint and termination appear in the leakage current of the cable system.

The existing methods for cable diagnostic such as the measurement of the DC leakage current and or $\tan \delta$ require an interruption in electrical service and needs extensive installation work. For these reasons, in Japan some on-site on-line diagnostic methods such as the DC component current method and the DC superposition method are used to detect water tree deterioration. Accuracy of the DC component current method and the DC superposition method is compared. As a conclusion the on-line diagnostic methods are considered as efficient as the DC leakage current method. However, the method based on the DC superposition may not be applicable to all cables on-site. This is because with a low voltage (< 100 V), water tree can be detected in some cable, while in others superimposed voltage of 10 kV or more is necessary. At these relatively high DC voltages one must expect breakdown.

Combination of the measurement of $\tan \delta$ and the total harmonic distortion in the loss current is a new method for diagnostic on power cable systems. However, this method is still on the laboratory level. Moreover, the significance of the relative values of $\tan \delta$ and the total harmonic distortion current in the insulation is not yet understood. Results of accelerated ageing studies show that $\tan \delta$ and water trees of polymeric cable increase with acceleration time and voltage, which both are important. However, as an example, acceleration at 16 kV for 2000 h increased $\tan \delta$ more than acceleration at 20 kV for 1000 h. Even with 2000 h acceleration at 12 kV, the water treeing is more pronounced than with 1000 h at 20 kV.

The $\tan \delta$ and capacitance of water-treed cable (e.g. at 70 °C), measured at power frequency (50 Hz) but variable voltage seems to decrease with increasing voltage. This is mainly due to heating of water in the trees due to long lasting measuring voltage (hand balanced Schering bridge). Reason for this is that relative permittivity of water decreases with temperature

($\epsilon_r = 80$ at 20 °C and e.g. 60 at 60 °C), and long lasting measuring voltage application heats the water. Thus, this effect is not real but result of measuring conditions, and it is reversible. Also the water tree canal diameters decrease due to heating thus decreasing, the capacitance and $\tan \delta$.

Independent of conditions, $\tan \delta$ and capacitance have very good correlation.

Dielectric Response as Diagnostic Tool for Power Cable Systems

Many research groups have carried out measurement of dielectric response of oil-paper insulation systems either in time domain or frequency domain. The dielectric response in both domains provides novel diagnostic methods for quality control of medium and high voltage cables. However, the information obtained in frequency and time domain is equivalent only if the insulation system is linear. In addition, dielectric response measurements in both domains indicated that measurement of non-linearity in the dielectric response could become the basis for diagnosis of water tree degradation in cable. Non-linearity in the dielectric response has been subject of study in many doctoral theses.

Measurement of loss angle of oil-paper cables as a function of frequency is normally performed using a low voltage power supply. Higher moisture content of insulation will increase loss angle. Anyhow, this behavior is not so clearly seen through whole frequency range. Loss angle curves representing different moisture contents can cross each other. The loss angle has a minimum value which tends to increase with higher moisture content. This means that the assessment of insulation condition for different mass impregnated cables regarding its moisture content can be based on the minimum of loss angle.

Polarization (charging) and depolarization (discharging) currents of oil-paper insulation will increase with moisture content. In addition to dielectric response function, the time domain measurement of polarization and depolarization currents allow for estimation of the conductivity of the test object. Increase in moisture content will increase conductivity. It is important to observe that the conductivity of oil paper system is strongly dependent upon the temperature. Without knowledge of temperature no simple criterion based upon the conductivity can be used to estimate the moisture content. Dielectric response gives an overview of average condition of the insulation system under study, but no localization of the possible deteriorated areas. Predicting the remaining life of the insulation system based on DR and/or other measurements requires still further research work. [14], [15]

6 Combined TD/PD Cable Diagnostic

The BAUR VLF Diagnostic System is the outstanding equipment on the market and has become approved by numerous power utilities during the past decade. Together with the BAUR VLF generators a compact testing and diagnostic system is available which is unbeaten in reliability, performance and effectiveness.

The most important advantages of BAUR equipment can be summarized as follows:

The BAUR **TanDelta** diagnostic equipment is rigid and **independent on external influences**. The system is well proven with 100'000 of measurements around the world. This gives an enormous database of which all customers get benefit from. More than 300 systems are in operation world-wide. The measurement time is only 10 min per phase or approx. 1h for a complete system roll on and off. The system is easy to use and operate. The interpretation of results is mostly automatized by the computer.

The BAUR **PD** system as well as the TD system is an **integrated system**, giving a very low weight and dimensional addition to the generator.

VLF testing and PD diagnostic at the same time is very useful **during installation and maintenance testing**. The BAUR PD system is the technically most advanced one on the market. More than 400 systems operating throughout the world show reliable data. [6]



Figure 25 BAUR VLF TD series: PHG80 TD (57kVrms); VIOLA TD (42,5kVrms); FRIDA TD (24kVrms)

6.1 Why to use VLF Diagnostic

6.1.1 Dissipation factor: VLF versus power frequency

Due to the time effect of depolarisation, **water trees (WT) in solid dielectrics are more sensitive to the dissipation factor using lower frequencies.** The classification of a good, medium or severely WT aged cable condition is more effective by using VLF, compared to 50 Hz or variable frequencies.

Loss Factor simulations using mathematical correlations, e.g. **based on damping factor of an oscillating wave, is fully dependant on the length of the measured cable.** Furthermore the Tan Delta (TD) and delta TD at voltage rise and descent can give a more detailed answer on diagnosing water ingress in joints or terminations [14]. The user has to rely on a consistent data base, especially if severe criteria are used that are expensive and need maintenance. Calibration and validations procedures have to be carefully handled; wrong decisions in field environment may become very costly. [1]

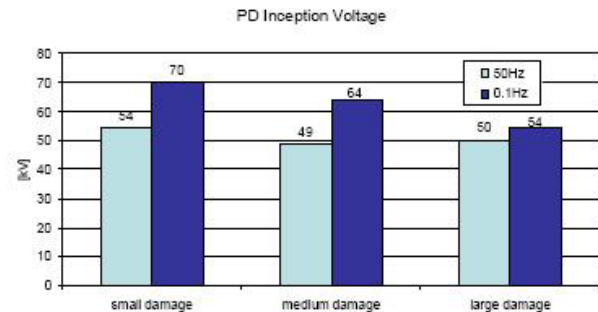

Figure 26 PD Inception voltage on a 110 kV XLPE cable (9,10), [1]

6.1.2 PD: VLF versus Power Frequency

The comparative characteristics of Partial Discharge behaviour at 0.1 Hz and 50 Hz is shown in Figure 27. They show that VLF at 0.1 Hz has the **highest coincidence in relation to 50Hz**, whereas Cos-Rect. VLF waveform or oscillating wave OWTS are highly different in PD level and rate.

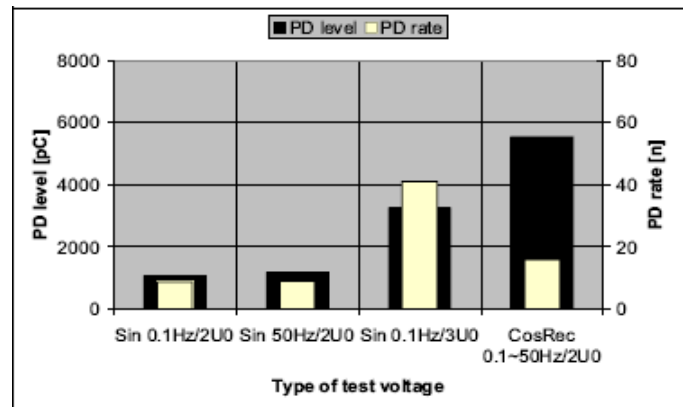

Figure 27 PD levels with 0.1 Hz sinusoidal wave shape, 50 Hz power frequency and Cos-Rectangular 0.1 Hz [16]

Results, based on sinusoidal waveform are shown in Figure 28. Quite similar results can be found in respect of PDIV. The **ratio is varying in all cases with less than 10%**. As we can see, also at higher voltage levels up to 80kV, the VLF is showing comparative results. Very similar PD patterns at higher sinusoidal voltage levels on different artificial joint faults on a 110 kV XLPE cable have been identified. [16]

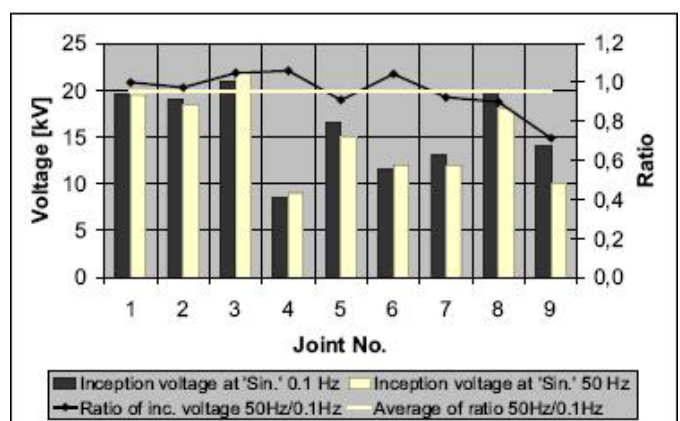

Figure 28 Partial discharge inception voltage in comparison with HV source [16]

7 TD Loss Factor Measurement - TanDelta

7.1 Basic background of Tan δ Dissipation factor (TD)

Tan δ is a measure of the degree of real power dissipation in a dielectric material and therefore its losses.

In the case of underground cables, this test measures the bulk losses rather than the losses resulting from a specific defect. Therefore, Tan δ measurement constitutes a cable diagnostic technique that assesses the general condition of the cable system insulation. Tan δ can be employed to all cable types; however, test results must be considered with respect to the specific cable insulation material and accessory type.

For modelling, the cable insulation system is simply represented by an equivalent circuit that consists of two elements; a resistor and a capacitor, see Figure 30.

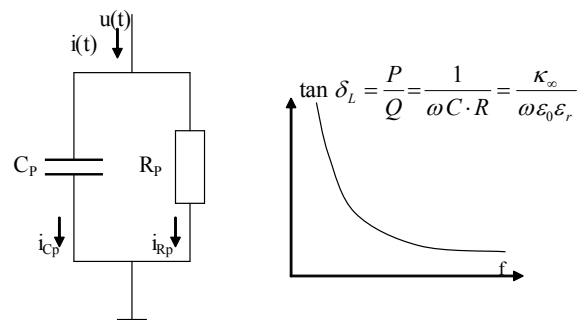

Figure 29 Simplified single line diagram used to describe DPF at one single frequency [12]



Figure 30 Extract of IEEE 400.2-2001, Fig.6 – Phasor diagram for high loss dielectric material [12]

When voltage is applied to the cable the total current (I) will be the contributions of the capacitor current (I_C) and the resistor current (I_R). Tan δ is the ratio between the resistor current and the capacitor current. The angle δ is the angle between the total current and the charging current when they are represented as phasors. [12]

The measurement of the Tan δ value is often also described as Tan Delta, TD, Loss Factor or Dissipation Factor measurement.

Figure 31 shows the different Tan δ values for different polymer insulated cables. The values indicate that Tan δ at 0.1Hz is different from 50Hz.

Diagnostic methods, like partial discharge (PD) and dissipation factor (TD) measurements are recommended in order to control the insulation condition under HV stress, based on a voltage waveform which is conform to the IEC 60060-3 standard. Diagnostic tests, starting at a voltage level of **0.5U_o rising to a maximum of 2U_o**, are common in practice and are, therefore, **comparable with values between phases and historical data**. The maximum diagnostic voltage level should be carefully handled avoiding incipient cable failures, especially on aged cable systems. If the cable condition is unknown or in a critical stage, the applied **voltage level should never reach higher limits as recommended by the manufacturer or user**.

Avoiding a possible breakdown of the insulation, the operator might limit the voltage level far below the dielectric strength or at least reaching TD tip up criteria or the partial discharge inception voltage level. [2]

Acc. Figure 32 the dissipation factor should be strongly depending on frequency. Due to the resonant frequency of space charge polarisation the measured values are nevertheless comparable. For different insulating materials $\tan \delta$ might be higher or lower.

Figure 34 shows the high sensitivity of $\tan \delta$ measurements at 0.1Hz on water trees compared to 50Hz measurements. Figure 33 show the $\tan \delta$ at 0.1Hz increases significantly with test voltage level. This resulted in the expression of limits for XLPE and PE cables mentioned below. [2]

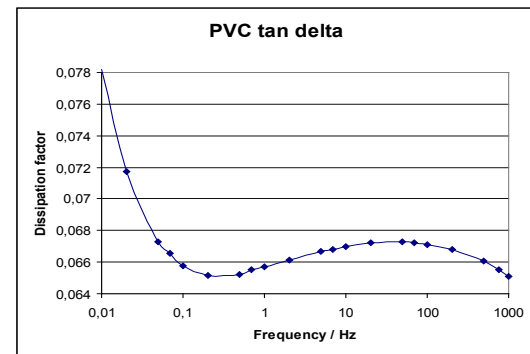
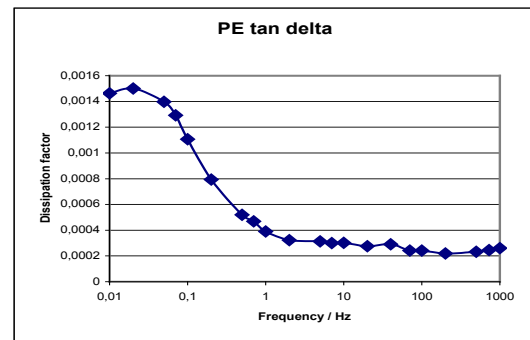

Figure 32 Frequency domain spectroscopy of service aged PE and PVC cables [2]

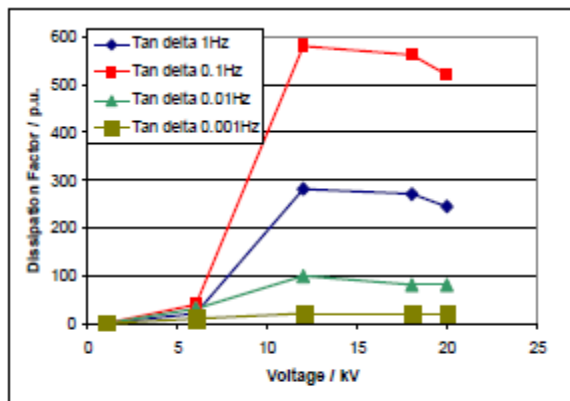

Fig. 5: Comparison of non-linearity in the frequency domain of a heavily watertree aged XLPE cable [Kus, 1998]

Figure 33 Comparison of non-linearity in the frequency domain of a heavily watertree aged XLPE cable [Kus, 1998] [2]

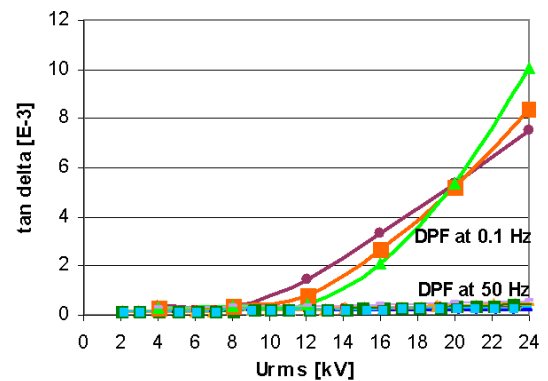

Figure 34 Nonlinearity of DPF at service aged XLPE cables at 0.1Hz and at 50Hz dug out 2008 [2]

7.2 Water Tree - Electrical Tree

The experience over the past years has shown that water-treeing is the major factor that determines the durability, especially of first-generation polymeric cables. While installation and mounting errors tend to be locally repairable, watertreeing occurs in areas where extension of the equipment life can only be

Figure 37 Illustration of "bow-tie" trees and "vented" trees

achieved through the replacement of sections or through chemical refurbishment. Water-treeing is an effect to the physical background which has not yet been fully explained despite various theories. Basically, water trees are channel-shaped structures which develop in the form of minute trees in the insulating material as a result of moisture and electrical fields emanating from defects. The electrical conditions prevalent in these water-trees, which are mostly invisible to the naked eye, differ from those in the healthy surrounding insulating material and this feature can be utilised for their measurement. The development of water-trees is a procedure that takes several years. Water-trees can occur continuously in a cable without reducing its functional capacity. The critical phase is entered when the PD-inception field strength at the tips of a water-tree is exceeded. Water-trees can be determined by the TanDelta measurement, as they are influencing the leakage current along the cable. As they are not accompanied by partial discharges, water trees cannot be located like partial discharges.

Electrical treeing is a process which, unlike water-treeing, takes place only at sports **of high local electrical field strength** and is followed by a series of partial discharges. The resulting hollow channel-shaped structures are however visible to the naked eye (Figure 39). The final **breakdown** of the insulation path under the influence of electrical trees is sometimes just a question of **minutes or hours**.

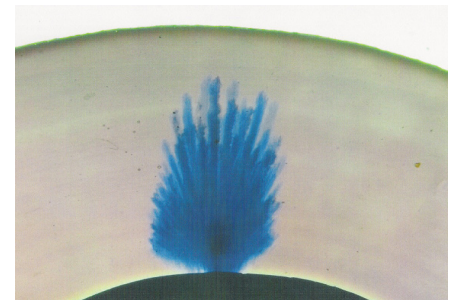

Figure 36, water tree, channel shaped structure

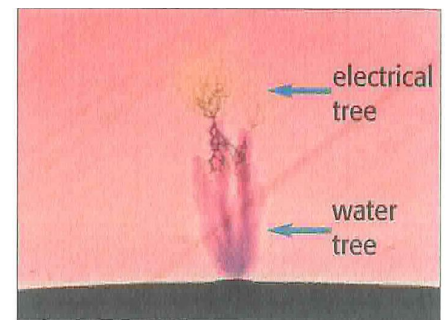

Figure 35, water tree with developing level of electrical tree, PD activity

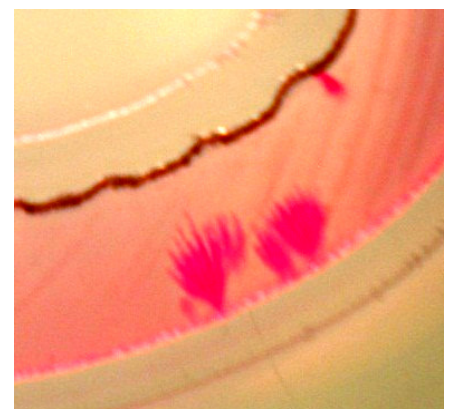

Figure 38, water tree, channel shaped structure

Unlike Water-Treeing, **Electrical Treeing can be detected by PD measurement.**

Since long water-trees in the insulating material are likely to pave the way for future electrical trees, they can also be used to measure the ageing condition of a plastic insulated cable. A method of diagnostic which does not give just a "go/no-go" appraisal, but which also evaluates the overall condition of the cable insulation, must produce a measurement value which will correlate very well with the "concentration" of long water-trees. Even though this "insight" into the cable insulation can only give an **integrated result**, significant similarities can be detected in most cases between the results of the measurements and the actual state of the cable using appropriate methods of diagnostics.

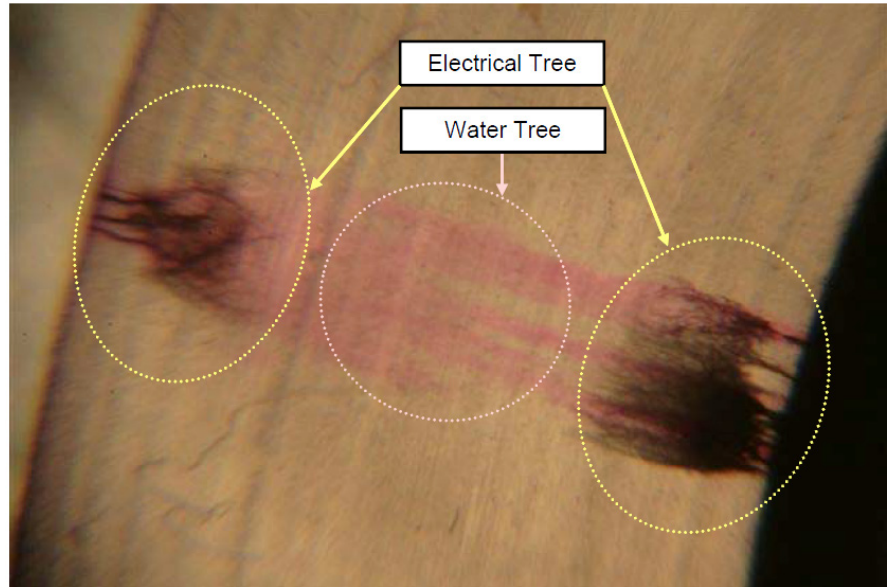

Figure 39 Photo of actual water tree and electrical tree after dissection (XLPE cross section)

The higher the dissipation factor of the insulation, the lower is dielectric strength.



Figure 41 Aged XLPE insulation, voids in XLPE, 115kV cable

Figure 40 Incomplete degassing of the cable in the factory, after 14 months in operation

7.3 Tan δ Measurements on Service Aged Cables

In the past few years, most of the industrialized countries beside Europe also started to follow the diagnostic guidelines established in Europe. Due to different design of particular cables, the test voltage up to $2U_0$ has been questioned. Based on this, NEETRAC performed numerous field tests and carried out research works. Results and experience shall be summarized in the following chapter.

In this section, Tan δ measurements carried out in the field are considered. The testing has been performed at one of the utilities participating in the CDFI project. Its name is not revealed here because of the confidential nature of the data. The utility decided to conduct Tan δ measurements on 25 kV XLPE direct buried cable system that initially operated at 15 kV and was upgraded to 25 kV operations in 2006. A considerable number of failures occurred after the system was upgraded and the utility seriously considered total replacement of affected subdivisions.

Tan δ measurements were conducted at 0.5, 1.0, 1.5 and 2.0 x U_0 . Figure 42 shows the cumulative distribution functions of the Tan δ field data for all test voltages.

The results show that if the values given by the IEEE Std. 400 (Clause 8.4) [12] are considered for assessment, 64% of the cables are considered to be highly degraded, 16% to be aged, and only 20% is considered to be in good condition.

These proportions seem to be extreme in the sense that a follow-up record of onsite failures after testing has been kept and to date no more failures have occurred. This test was conducted in July 2006. Similar results are obtained when evaluating the data using the tip-up criteria. This could be an indication that the values as given for the standard are probably too conservative or that more features for evaluation are needed.

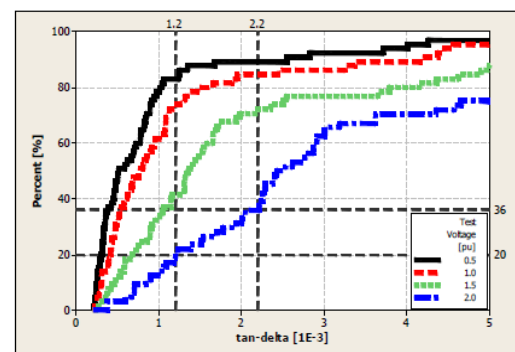

Figure 42 Cumulative distribution functions TanDelta field data for >10.360m of cable measured [17]

Influence of some field condition issues on the interpretation using the standard equivalent circuit:

Tan δ measurements are most often interpreted in terms of a simple circuit within a parallel connected resistance and capacitance. This equivalent circuit lumps all of the contributions along the length into single circuit elements. Thus it should be clear that to achieve the correct interpretation the correct equivalent circuit needs to be used. In the course of the work reported here it has been determined that there are at least three important cases where the assumption of the simple equivalent circuit may not be completely appropriate:

- The presence of Partial Discharge (PD).
- Corroded Neutral wires.
- Non-uniform water tree degradation.

It has been seen in the laboratory measurements that there is an effect of PD on the measurements of $\tan \delta$.

This is for at least two cases:

- Corona at the terminations and PD from large voids within the cable insulation. The first case may perturb the measurement in that the corona discharge current adds to the measured leakage current. Thus this may not really be considered as adding to the cable loss. Nevertheless, it does indicate the importance of ensuring discharge free terminations when conducting any sort of measurement in the field.
- For the second case of large void discharge within a cable, the presence of internal PD can increase the measured $\tan \delta$ value for XLPE cables by almost an order of magnitude. If tested lengths of cable contain PD, which often comes from accessories, then this effect can complicate diagnostic.

There is no question that the simple equivalent circuit does not account for this situation. A more elaborate model should be used. At the present, there is no indication on which model to use; thus, research efforts are required in this area.

When there is significant corrosion of the neutral wires, the $\tan \delta$ value will also contain a contribution from the equivalent model series resistance. The simple model approach assumes that the series resistance, comprised of the shield resistance, the neutral wire resistance and any contact resistance are small. When there is significant corrosion of the neutral wires then the previous assumption is incorrect. In this case the $\tan \delta$ will contain a contribution from the length dependent series resistance. Therefore, it is expected that there will be an increment in the $\tan \delta$ value that is a function of length when the neutral wires are corroded. In other words, the total power losses will be the result of the contribution of the bulk insulation losses and the length dependent series resistance losses. This leads to a situation similar to the one for partial discharge but with different diagnostic features. This situation has been observed in other field $\tan \delta$ measurements conducted by the CDFI Project. [17]

If higher density regions of water trees exist only in part of the cable segment length; their effect on $\tan \delta$ would not be reflected in the measurement. In other words, the overall $\tan \delta$ value may be lower than the value that corresponds to the high density regions of water trees.

Figure 43 shows two cases for a cable section with non-uniform water tree degradation; the situation can be modelled by making the proper modifications to the equivalent circuit in order to identify useful diagnostic indicators for the $\tan \delta$ values and tip-up. [17]

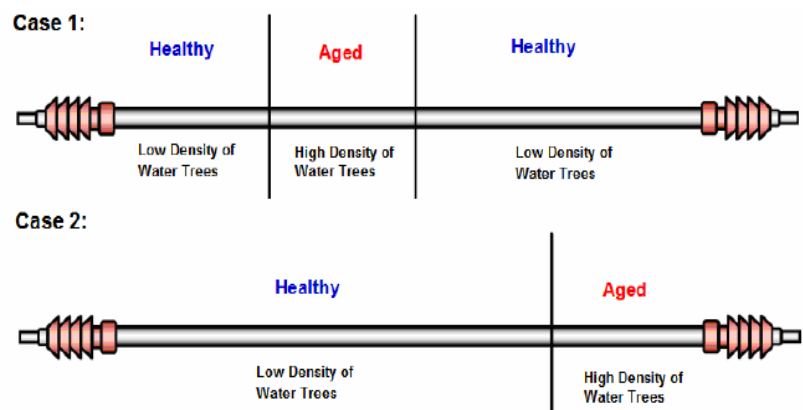

Figure 43 cable section with non-uniform water tree degradation

7.4 $Tan \delta$ - Measurement at lower test voltages

The field data has revealed a way in which $Tan \delta$ values may be collected and compared to data at lower stresses or testing voltages. The conditioning and comparison methods enable existing success criteria used at the higher stresses to be mapped to lower levels of stress. Thereby providing the same level of discrimination, but delivering this at lower stresses. This significantly reduces the risk of failure under the test.

The level of risk reduction may conveniently be estimated from an appropriately parameterized version of the well-known Weibull Equation as mentioned before.

Figure 44 shows the correlation between $Tan \delta$ measurements from field testing at 2.0 U_0 and 1.5 U_0 for modified diagnostic criteria. The voltage of 1.5 U_0 represents a lower risk of failure during testing to the cable system.

The plot shows a relationship between the data collected at the different voltages. The clarity of the plot is improved by adopting logarithmic scales which further facilitate the identification of the relationship. In this case, the relationship is linear in logarithmic terms, but this need not be so. It is sufficient that the relationship is clear.

The vertical lines represent the already established success criteria from the IEEE Std. 400. In the absence of the relationship it is clear that an engineer wishing to utilize the experience set out in IEEE Std. 400 is constrained to test at 2.0 U_0 . This forces the engineer to accept a higher level of risk than he may be comfortable with.

With the relationship, it is a straightforward procedure for the engineer to translate the success criteria from the higher stress (1.2, 2.2 and 4 values on the upper X axis for 2.0 U_0) to a lower stress (0.7, 1.3 and 2.3 on left right hand Y axis for 1.5 U_0) thus reducing the risk. Therefore, such a relationship demonstrates that it is possible to develop criteria for different voltages in a very convenient way.

New evaluation criteria for TD measurement on aged cables are also discussed in the new recommendation mentioned in the IEEE400.2 D12 draft 2012 [18].

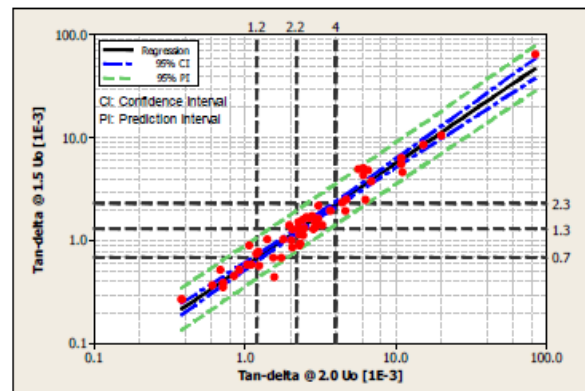

Figure 12: Correlation between $Tan \delta$ measurements from field testing at 2.0 U_0 and 1.5 U_0 for modified diagnostic criteria

Figure 44 Evaluation criteria adapted to 0.5 U_0 to 1,5 U_0 [17]

7.5 TD Evaluation – important parameters / Influences

7.5.1 Important Parameter for TD interpretation

1. Absolute TD Value

Acc. To IEEE 400.2-2001 ... up to $2 \times U_0$

Acc. To IEEE400.2-2013
for service aged cables ... up to $1,5 \times U_0$

Cables actually are still in **good condition**,
do not have to be replaced:

$\tan d (2 U_0) < 1.2 \text{ ‰}$

Cables **with high operating risk**:

$\tan d (2 U_0) > 2.2 \text{ ‰}$



TD graph: Cable in good condition, $< 1.2 \cdot 10^{-2}$ @ $2 U_0$, IEEE

Figure 45 Evaluation of TD results, TD Average Value Criteria [19]

2. Delta Tan Delta DTD

DTD (Delta TD)

$[2 U_0] - [U_0]$ Defined in IEEE

Indication of

=> **PD activity or Water trees**

Cables actually are still in **good condition**:

$[\tan d (2 U_0) - \tan d (U_0)] < 0,6 \text{ ‰}$

Cables **with high operating risk**

$[\tan d (2 U_0) - \tan d (U_0)] > 1,0 \text{ ‰}$

Reference: EWE, acc. to IEEE 400.2

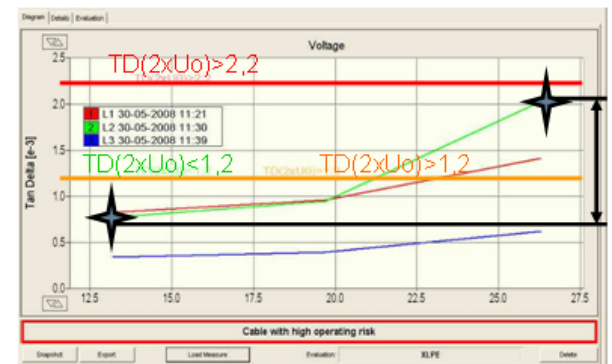

TD graph: Cable with high operating risk,
DTD ($2U_0 - U_0$) $> 1.0 \cdot 10^{-3}$, IEEE 400.2

Figure 46 Evaluation of TD results, DTD [19]

3. Graph comparison

Comparison of L1, L2, L3

same condition in all phases

=> same TD graph

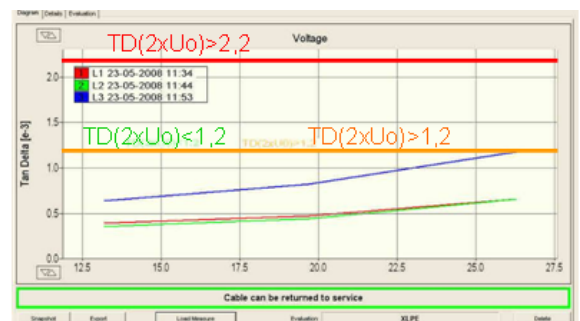

TD graph: Cable in good condition, $< 1.2 \cdot 10^{-2}$ @ $2 U_0$, IEEE

Figure 47 Evaluation of TD results, Phase comparison [19]

4. Stability – Standard Deviation

Details:

#	Time	Voltage KV	Current mA	Tan Delta E-3
1	13:04:48	6.5	8.1	0.22
2	13:04:59	6.5	8.1	0.22
3	13:05:08	6.5	8.1	0.22
4	13:05:19	6.5	8.1	0.22
5	13:05:29	6.5	8.1	0.22
6	13:05:39	6.5	8.1	0.22
7	13:05:50	6.5	8.1	0.22
8	13:06:00	6.5	8.1	0.22

```
Phase .....: L1
Date/Time .....: 12-07-2007 13:06:01
Step .....: 1
Avg. Value Tan Delta .....: 0.217 E-3
Standard Deviation .....: 0.001 E-3
No. of Tests .....: 8
Load .....: 1989.3 mF
Test sample VSE current .....: 36.0 uA
Generator VSE current .....: 2.0 uA
```

Definition of Standard Deviation

The standard deviation is defined as the average amount by which scores in a distribution differ from the mean, ignoring the sign of the difference.

$$s = \sqrt{\text{var}} = \sqrt{\frac{\sum(X - \bar{X})^2}{N - 1}}$$

The TD Standard Deviation established to be a very useful figure in analyses of the reason for degradation.

Further, the trend direction is very important!

TD-Stability as indicator of weakness in the cable

Std. Deviation / Stability	Indication	Required measurement	Required action	Comment
< 0,010	- Cable in good condition - Water trees - only few PD's	TD PD	No immediate action, cable in good condition	DTD usually low No PD or no intensive PD
0,010 to 0,100	Water trees + PD Only concentrated PD	TD PD	Moderate water tree aging if no PD; PD concentration to be analysed	Moderate water tree aging => no immediate action Replacement of joint if PD concentrated
0,100 to 0,500	water ingress in joints	TD PD may not show high PD values	Only TD can indicated this effect PD results to be considered as damped due to the presence of water. PD value criteria cannot be applied!	Sheath fault location might indicate the location of the joint w/ water ingress. Water in – leakage current out; joints indicating low PD have to be investigated even the PD value is low. PD calibration graph might deliver information on the location of the joint with water ingress
> 0,500	Very high water ingress in joint	TD PD are widely eliminated in affected joints	Only TD shows this effect PD does not show any weak point; immediate replacement of joint Investigation of PD calibration graph	Sheath fault location might indicate the location of the joint w/ water ingress. Water in – leakage current out PD calibration graph might deliver information on the location of the joint with water ingress

Table 5, TD Stability interpretation, suitable as general guideline [19]

5. Information of TD Details – TD Stability over time

#	Time	Voltage kV	Current mA	Tan Delta E-3
1	11:47:14	1.4	0.0	0.40
2	11:47:24	1.4	0.0	0.41
3	11:47:33	1.4	0.0	0.42
4	11:47:44	1.4	0.0	0.42
5	11:47:54	1.4	0.0	0.42
6	11:48:04	1.4	0.0	0.42
7	11:48:14	1.4	0.0	0.43
8	11:48:24	1.4	0.0	0.43

Phase : L1
 Date/Time : 04-11-2010 11:48:25
 Step : 1
 Avg. Value Tan Delta : 0.419 E-3
 Standard Deviation : 0.009 E-3
 No. of Tests : 8
 Load : 41.4 nF
 Test sample VSE current : 8.0 uA
 Generator VSE current : 0.0 uA

#	Time	Voltage kV	Current mA	Tan Delta E-3
1	11:49:45	2.9	0.1	2.55
2	11:49:55	2.9	0.1	2.65
3	11:50:05	2.9	0.1	2.73
4	11:50:15	2.9	0.1	2.81
5	11:50:25	2.9	0.1	2.80
6	11:50:35	2.9	0.1	2.86
7	11:50:45	2.9	0.1	2.90
8	11:50:55	2.9	0.1	2.94

Phase : L1
 Date/Time : 04-11-2010 11:50:56
 Step : 2
 Avg. Value Tan Delta : 2.781 E-3
 Standard Deviation : 0.124 E-3
 No. of Tests : 8
 Load : 41.0 nF
 Test sample VSE current : 16.0 uA
 Generator VSE current : 0.3 uA



Upward trend 0.40 to 0.43 E-3 // 2.55 to 2.94
 Losses are developing, tracking
 PD track-development
 Water tree presence

#	Time	Voltage kV	Current mA	Tan Delta E-3
1	11:52:16	4.3	0.1	5.27
2	11:52:26	4.3	0.1	4.90
3	11:52:36	4.3	0.1	4.65
4	11:52:46	4.3	0.1	4.46
5	11:52:56	4.3	0.1	4.46
6	11:53:06	4.3	0.1	4.26
7	11:53:16	4.3	0.1	4.08
8	11:53:26	4.3	0.1	3.92

Phase : L1
 Date/Time : 04-11-2010 11:53:27
 Step : 3
 Avg. Value Tan Delta : 4.500 E-3
 Standard Deviation : 0.412 E-3
 No. of Tests : 8
 Load : 40.8 nF
 Test sample VSE current : 24.0 uA
 Generator VSE current : 2.0 uA

#	Time	Voltage kV	Current mA	Tan Delta E-3
1	11:54:47	5.8	0.2	4.26
2	11:54:57	5.8	0.2	4.13
3	11:55:07	5.8	0.2	4.02
4	11:55:18	5.8	0.2	3.86
5	11:55:27	5.8	0.2	3.87
6	11:55:37	5.8	0.2	3.73
7	11:55:47	5.8	0.2	3.61
8	11:55:58	5.8	0.2	3.50

Phase : L1
 Date/Time : 04-11-2010 11:55:58
 Step : 4
 Avg. Value Tan Delta : 3.872 E-3
 Standard Deviation : 0.240 E-3
 No. of Tests : 8
 Load : 41.1 nF
 Test sample VSE current : 34.0 uA
 Generator VSE current : 2.0 uA

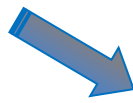

Downward trend
 5.27 to 3.92 E-3 // 4.26 to 3.50 E-3
 Humidity vaporizing during appl. of high voltage
 ⇒ TD measurement shall be repeated. Value will stabilize when water is vaporized.

Figure 48 TD Stability Trend interpretation [19]

7.5.2 TD Stability Trend Analysis

TD Stability Trend, as indication of leakage behaviour

⇒ Possible indications for TD trend behaviour in XLPE cables

<ul style="list-style-type: none"> • Stable values throughout the voltage stages • Low Std. Deviation <p>⇒ Stable condition</p> <p>⇒ Indication of PD activity, moderate water tree presence</p>	
<ul style="list-style-type: none"> • Increasing TD throughout the voltage stages • Moderate level of Std. Deviation <p>⇒ Development of leakage, tracking, thermal current</p> <p>⇒ Development of water tree to advance stage, electrical tree</p> <p>⇒ Indication of increase of leakage during appl. of voltage</p>	
<ul style="list-style-type: none"> • Decreasing TD throughout the voltage stages • Higher decreasing rate at higher voltages • moderate Std. Deviation <p>⇒ Indication of humidity presence</p> <p>⇒ Indication of PD, TD is increasing with the voltage</p> <p>⇒ Water/humidity will vaporize after the voltage is applied for a certain time</p> <p>⇒ Indication of water / humidity presence at terminations or joints</p> <p>⇒ Repeating measurement is recommended</p> <p>⇒ Water / humidity will vaporize and values will become more stable when repeating the TD measurement</p>	
<ul style="list-style-type: none"> • Negative DTD, dropping TD value over the voltage • Decreasing TD throughout the voltage stages • Higher decreasing rate at higher voltages • High Std. Deviation <p>⇒ Indication of humidity/ water presence</p> <p>⇒ Water will start to vaporize as soon as the voltage is applied</p> <p>⇒ Indication of water presence at terminations or joints</p> <p>⇒ Repeating measurement is recommended</p> <p>⇒ Water will vaporize and values will get more stable</p>	

Table 6, overview of TD trend pattern

To get a better overview of the stability trend during each of the voltage steps the arrow indication tool is used. Arrows pointing upward indicate positive trend of the TD value during one voltage step. A horizontal arrow indicates stable condition. An arrow pointing downwards indicates a decreasing TD value during one voltage level. The visualization of the stability trend allows getting a better understanding when comparing the behavior individual behavior for each phase. Three arrows are used for three voltage steps. The vertical position of the arrow allows drawing the absolute value of the TD average value at each voltage level.

7.5.3 Basic pattern of TD Trend Analysis based on cable elements

The below indicated TD Trend pattern are based on practical field examples. The project was carried out in cooperation with an Asian power utility that covered several hundred of medium voltage cables (11kV). Detailed cable information was available for each circuit. Combined TD / PD diagnostics and VLF testing results were combined and detailed case investigation was carried out. The database, where the individual TD trend patterns were recorded was finally evaluated with respect to the outcome of the case investigation. The below TD Trend pattern show the behavior of the TD time stability during each voltage step in correlation with the TD absolute values in respect to the applied voltage.

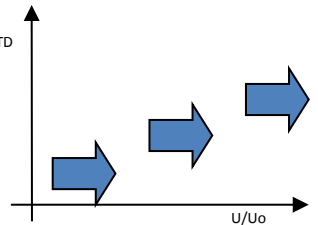
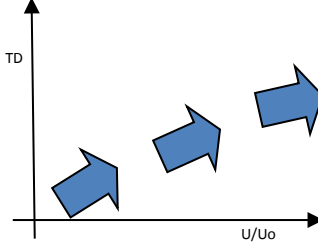
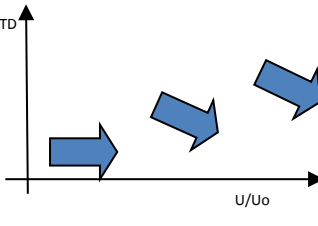
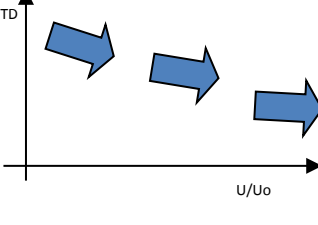
The key patterns allow understanding TD trend pattern for each of the possible elements that can be involved in Medium Voltage cable networks.

- XLPE cable in good condition, no water tree aging, no PD activity in joint(s)
- XLPE cable with water tree aging, no PD activity in joint(s)
- XLPE cable in good condition, PD activity in joint(s)
- XLPE cable in good condition, with joint(s) with minor water ingress, tracking in joint

- PILC cable in good condition, no PD activity
- PILC cable in aged condition, with PD activities
- PILC cable with tracking in a joint, minor PD activities
- PILC cable, highly service aged, with minor PD activities

Indicator	Calculation	Information
tan δ stability (SDTD)	Standard deviation of 6-10 measurements at U_0	<ul style="list-style-type: none"> - Partial discharges - Wet joints
delta tan δ (ΔTD)	Difference of the average values at 1.5 U_0 and 0.5 U_0	<ul style="list-style-type: none"> - Water trees - Partial discharges - Vaporization effects
mean tan δ (MTD)	Average value of 6-10 measurements at U_0	<ul style="list-style-type: none"> - Water trees - Ageing effects (Thermal, chemical)

7.5.3.1 TD Trend pattern – XLPE cable in good condition

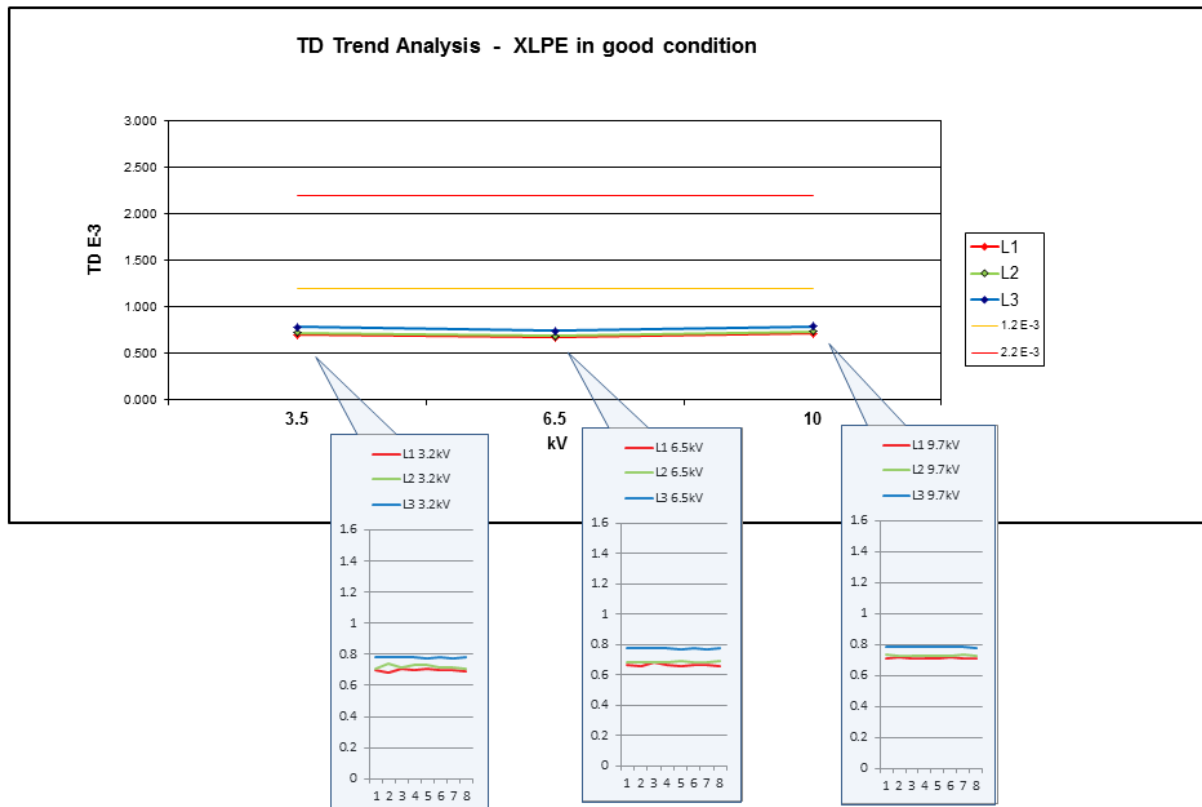

Figure 49 TD trend pattern - XLPE in good condition [19]

XLPE in good condition

- Low TD values
- Low DTD
- Low Std. Dev. < 0.010 E-3
- Stable Trend behaviour in all 3 voltage levels

Side information:

- No PD activities
- Total cable length 1688m
- 14 joints
- (7943S10)

7.5.3.2 TD Trend pattern – XLPE with high water tree aging

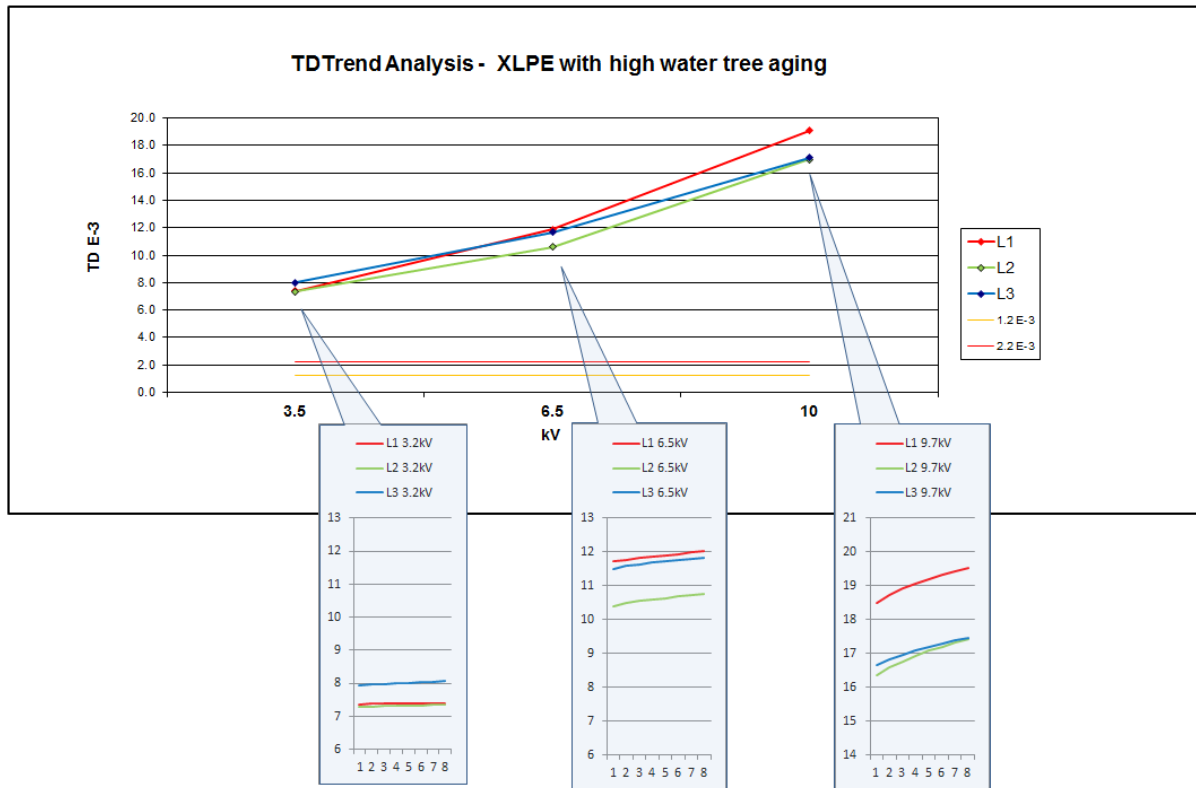

Figure 50 TD trend pattern, XLPE with high water tree aging [19]

XLPE with high water tree aging

- Increasing TD values
- High DTD
- Increased Std. Dev. < 0.500 E-3
- Increasing Trend behaviour with higher voltage

Side information:

- No PD activities
- Total cable length 933m
- 15 joints
- Water tree prone cable section (90%)
- (3814S03)

7.5.3.3 TD Trend pattern – XLPE cable with PD activities in joint(s)

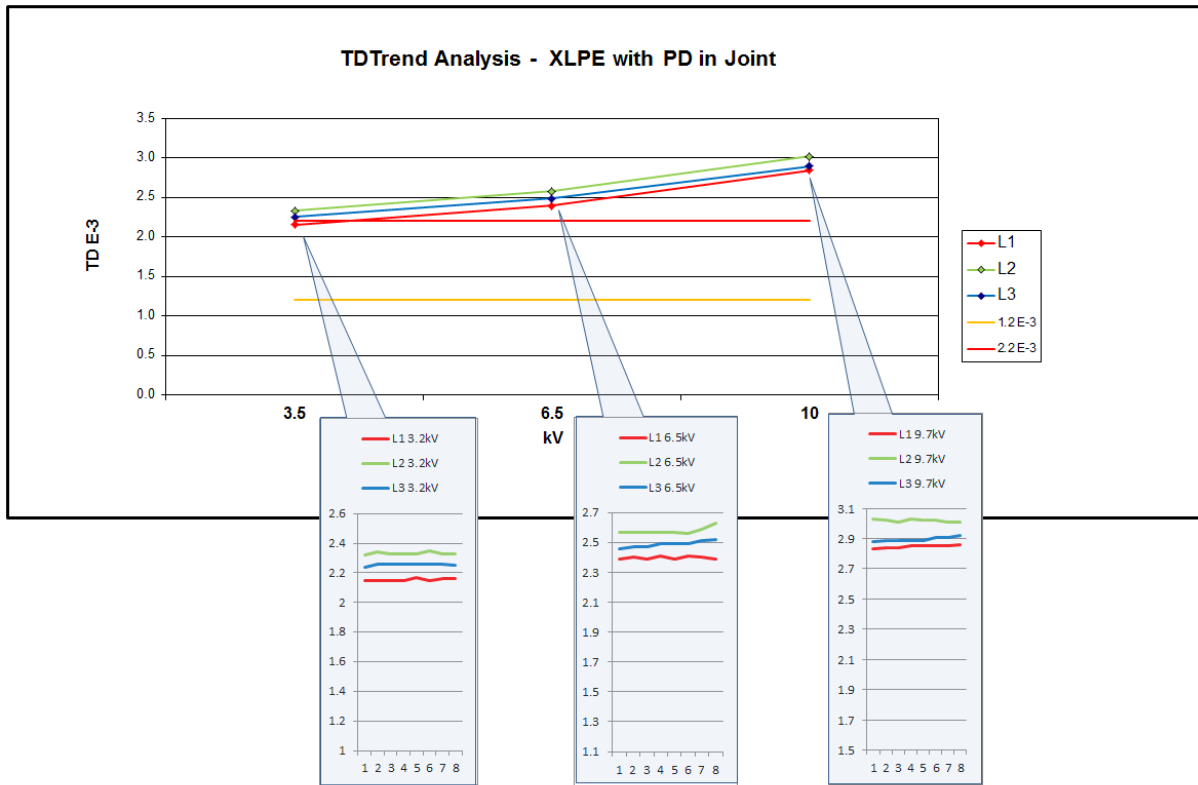

Figure 51 TD trend pattern, XLPE with PD activities in joints [19]

Side information:

- PD activities up to 3000pC
- Total cable length 102m
- 2 joints
- New XLPE
- (4579S11)

7.5.3.4 TD Trend pattern – XLPE cable with joint(s) with minor water ingress, tracking in joint

Figure 52 TD trend pattern, XLPE with joint with minor water ingress, tracking [19]

XLPE with joint with minor water ingress, tracking in joint

- High TD values
- Very high DTD
- High Std. Dev. > 0.500 to 5.0 E-3
- Decreasing Trend behaviour in the higher voltage levels possible

Side information:

- PD activities up to 300pC only
- Total cable length 186m
- 2 joints
- (12070S07)

7.5.3.5 TD Trend pattern – PILC cable without PD activities

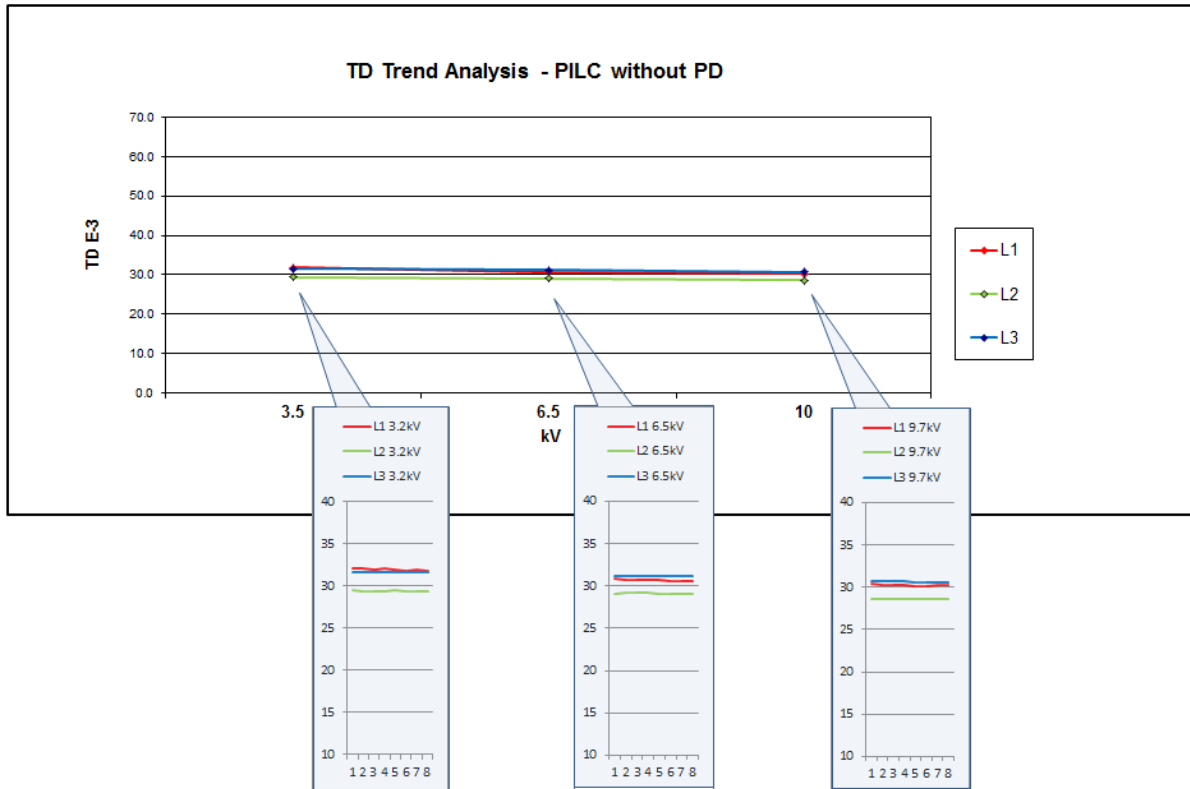

Figure 53 TD Trend pattern, PILC without PD activities [19]

PILC cable without PD

- low TD values (~ 30 E-3)
- very low DTD
- low Std. Dev. < 0.120 E-3
- stable Trend behaviour in all voltage levels

Side information:

- PD activities up to 1000pC in one joint
- Total cable length 1681m
- 12 joints
- (SS10850)

7.5.3.6 TD Trend pattern – PILC cable with PD activities

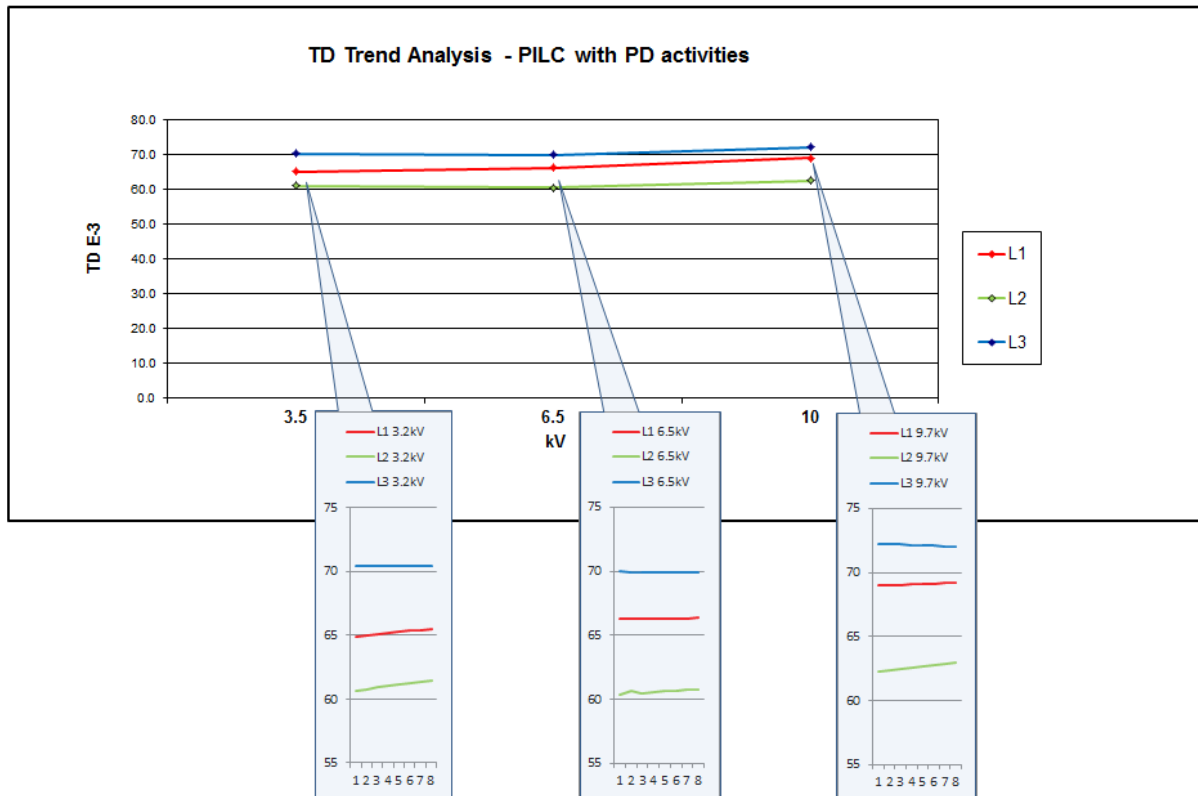

Figure 54 TD Trend pattern, PILC cable with PD activities [19]

PILC cable with PD activities

- TD values (~ 30 E-3)
- very low DTD
- low Std. Dev. < 0.120 E-3
- rather stable Trend behaviour in all voltage levels
- only slight tip up at $1.5U_0$

Side information:

- PD activities in PILC section up to 1000pC
- Total cable length: 481m
- 11 joints
- (1426S08)

7.5.3.7 TD Trend pattern – PILC cable with tracking in a joint, minor PD activities

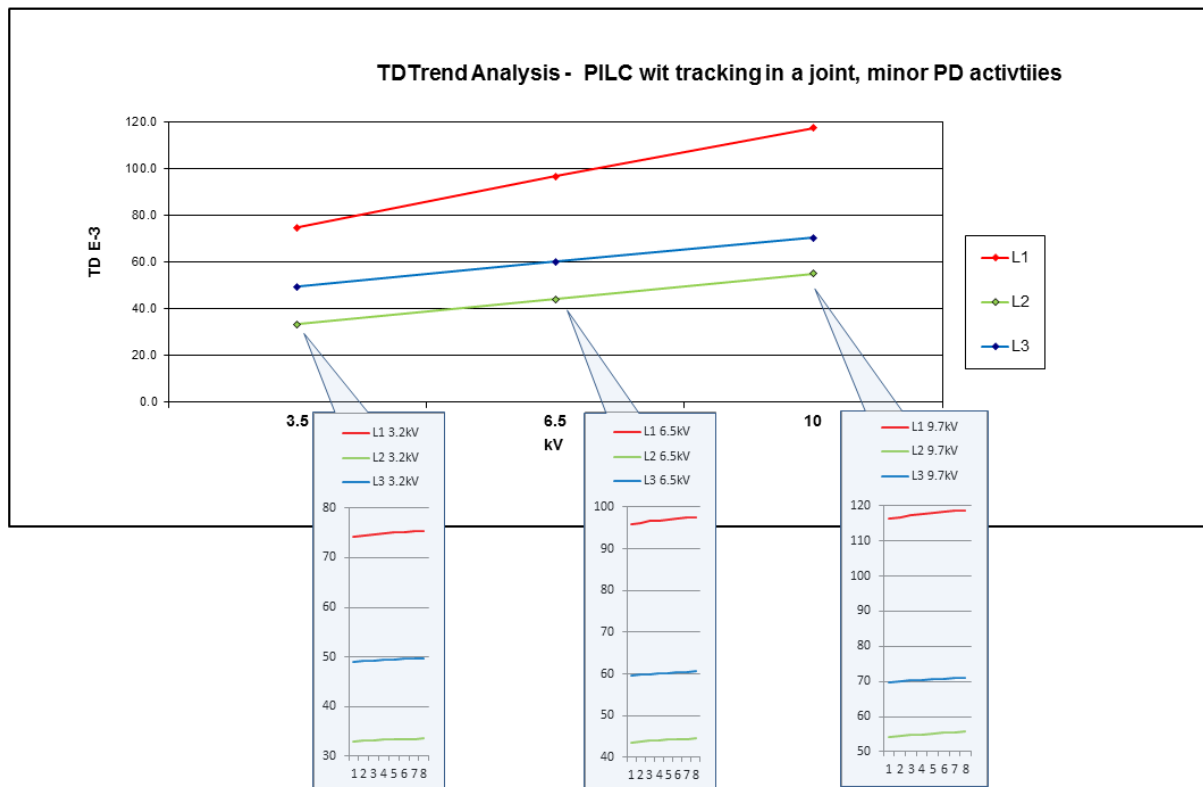

Figure 55 TD Trend pattern, PILC cable with tracking in a joint, minor PD activities [19]

PILC cable with tracking in a joint, with minor PD activities

- Increasing TD values > 70 E-3
- Very high DTD
- High Std. Dev. >0.500 E-3
- increasing Trend behaviour in the higher voltage levels

Side information:

- PD activities in PILC section up to 400pC
- Total cable length: 195m (mixed cable, 30% PILC AP)
- 2 joints
- (4892S12)

7.5.3.8 TD Trend pattern – highly service aged PILC cable, with minor PD activities

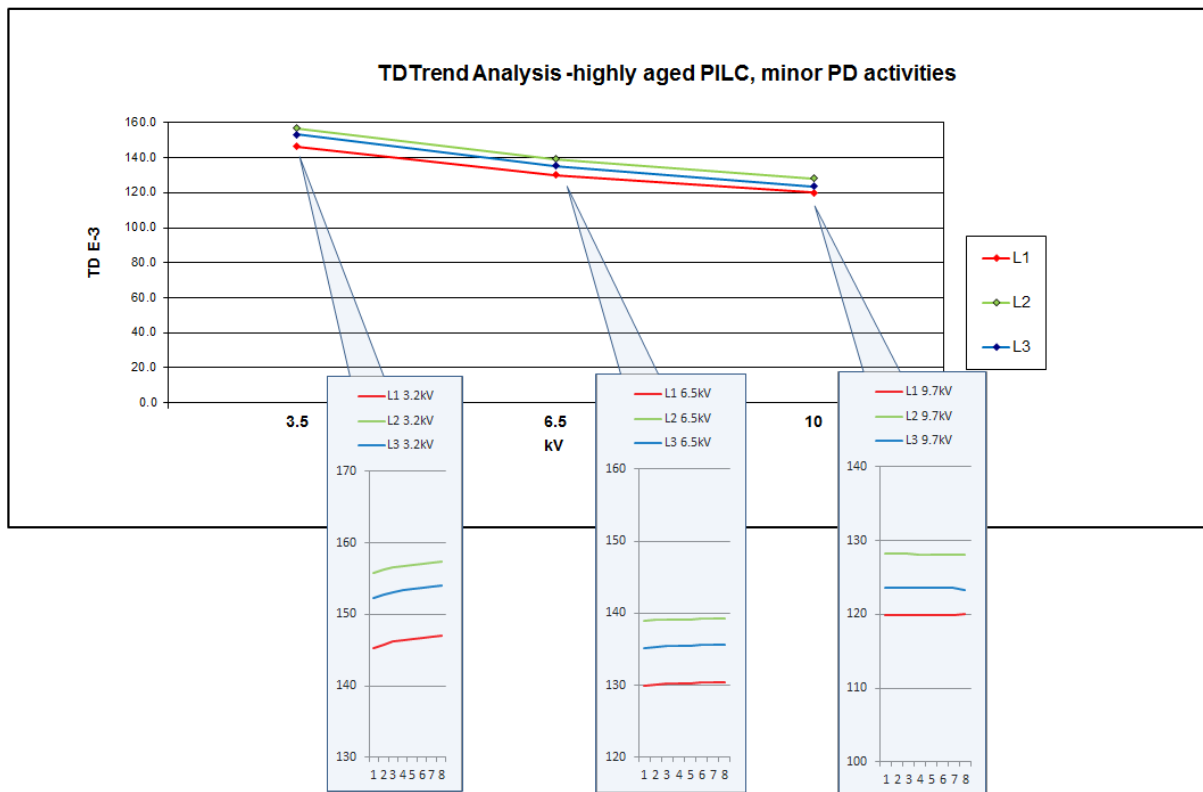

Figure 56 TD Trend pattern, PILC cable, highly service aged, minor PD activities [19]

Highly aged PILC cable with minor PD activities

- Moderate to high TD values > 70 E-3
- decreasing DTD
- high Std. Dev. > 0.500 E-3
- increasing Trend at low voltage level, stable and/decreasing Trend at higher voltage level

Side information:

- PD activities in PILC section up to 300pC
- Total cable length: 557m (mixed cable, 30% PILC AP)
- 2 joints
- (5525S04)

7.5.3.9 Summary on TD result analysis

TD analysis is a complex topic. Analysis need to combine different point of views:

- 1. Absolute TD value
- 2. Delta Tan Delta DTD
- 3. Phase Comparison
- 4. Analysis Stability at each voltage level
- 5. Analysis of Trend behaviour at each voltage level

Combinations of differently influencing components are very common. TD patterns represent the sum of all influencing components.

Like any other diagnostic technique for power cables, Tan δ is not free of issues. The issues are important because they can influence the outcome of the diagnostic assessment thus leading to a wrong evaluation. Therefore, a clear understanding on how the issues could influence the measurements and therefore the diagnostic is of paramount importance.

This section addresses some of the major issues of Tan δ measurements in field testing applications. As mention previously, the Tan δ can be considered as a measure of the integral condition of a cable.

A progressive increase of Tan δ value over time does indicate the presence of gradually growing water trees and therefore degradation. Thus in order to recognize this trend, records must be maintained over a period of time, typically several years.

In this case, when the Tan δ measurements exceed historically established thresholds of its value and changes with voltage (tip-up) for a particular insulation type, cable design, and voltage levels; the cable may be evaluated to be degraded and therefore it could be scheduled for replacement.

Cable accessories such as splices and terminations could have a significant effect on the measured Tan δ values. In fact, the accessories themselves could dominate the measurement since the losses for certain type of accessories are much higher than the cable insulation losses.

Therefore, when performing Tan δ measurements, the number of accessories and types must be considered in order to evaluate their effects on the measurement.

7.5.4 Examples for TD measurement – Trend of stability

Example 1:

L2, L3 stable condition

L1 water ingress in a joint, decreasing trend

Ramp-up curve

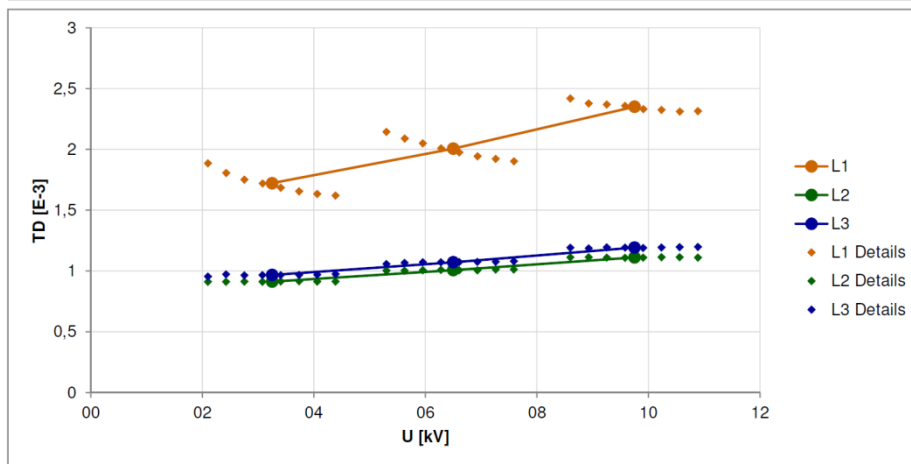

Figure 57, Ref. 2215CM, example L2, L3 stable condition, L1 water ingress in a joint

Example 2:

L2, L3 indication of tracking in at least one of the joints

L1 stable condition

Ramp-up curve

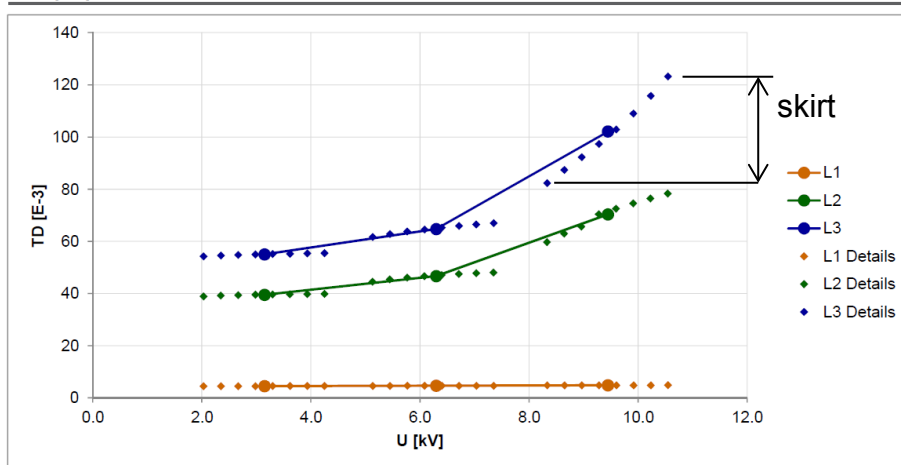

Figure 58, Ref. 8444CM, example L2, L3 tracking in joint, L1 stable condition

7.5.5 TD measurement – Result comparison over time

Tan Delta measurement as integral insulation performance measurement tool can be used as excellent tool to monitor the aging behaviour of cable circuits. The development of the dielectric losses over the time can be used as method to recognize the changing characteristic over time.

Very often, TD values are categorized as “further studies advised”. If no clear assessment of the source of degradation is possible, the retest after 6 month, 1year or 3 years is recommendable.

Comparing the values at different points in time allows understanding the reason for degradation and the urgency for further action can be defined easier.

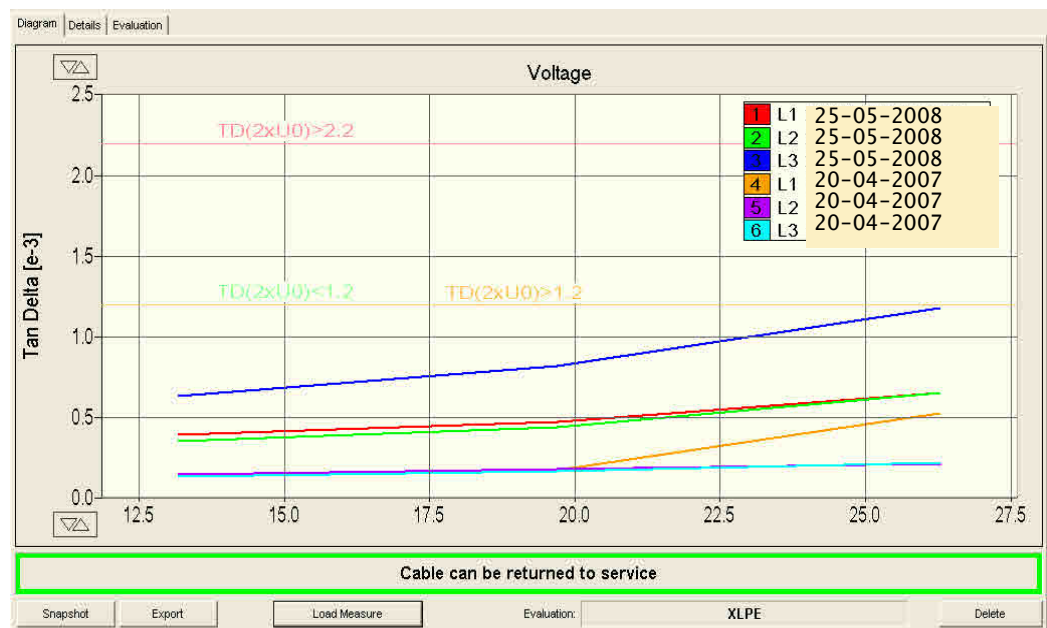

Figure 59 TD comparison of same XLPE cable after 1year; visible aging effect

7.5.6 Influence of surface currents in open terminations

Open terminations are subject to pollution, humidity and mechanical damage. These influences are mostly the reasons for high surface currents that may act as high leakage current during the TD measurement and therefore may influencing the result a lot.

Proper cleaning may help to reduce the surface conductivity of the termination in many cases but only to a certain extent. In certain environments a high relative humidity does not allow to eliminate this influence completely.

The complete and definite elimination of the influence of surface currents is most important. The application of the connection technique using guard rings and VSE-box (Virtual Safety Earth connection arrangement) is used.

Depending on the applied voltage level furthermore, the electric field at the termination lugs have to be homogenized by means of corona hoods.

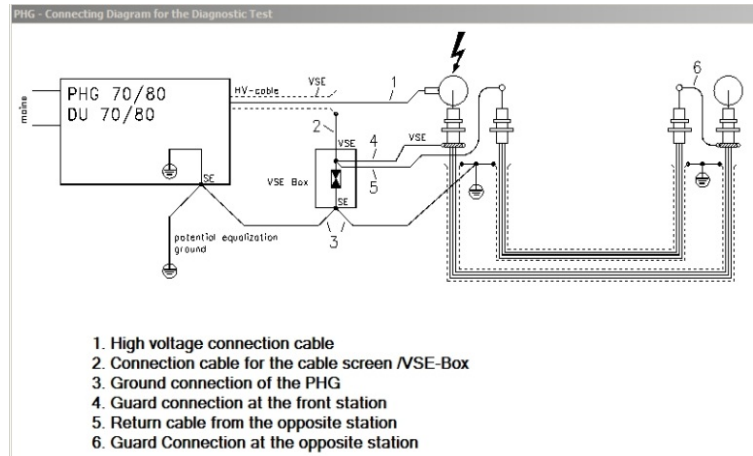
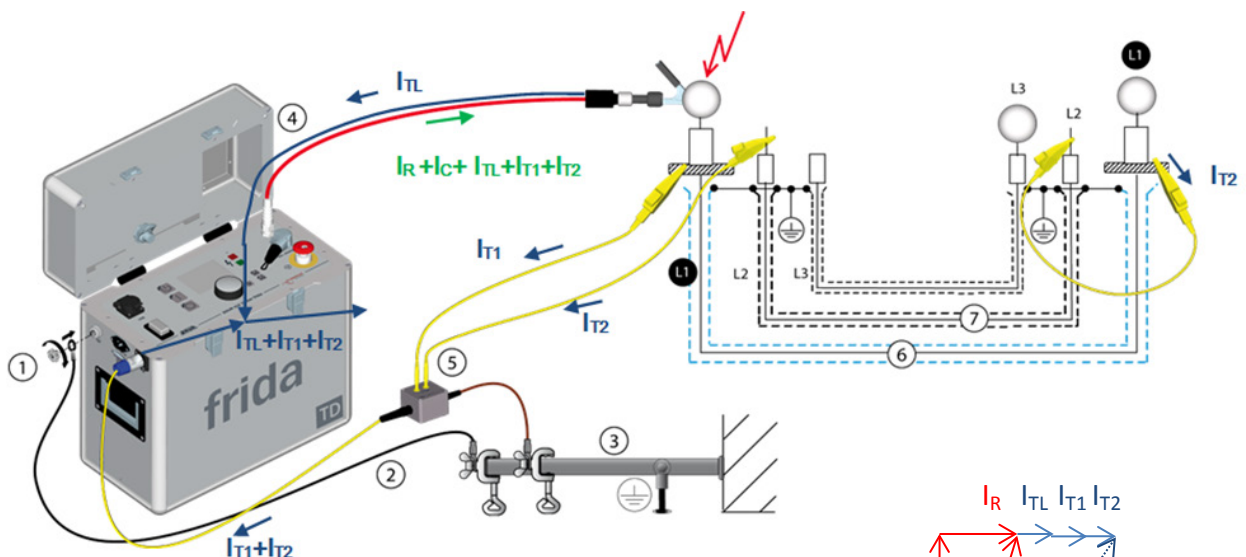

Figure 60 Programmable High voltage Generator (PHG) Connection Diagram for TD with guard ring application



TD Current: $I_{TD} = I_R + I_C + I_{TL} + I_{T1} + I_{T2} - I_{TL} + I_{T1} + I_{T2} = I_R + I_C$
 I_{TL} ... test lead leakage
 I_{T1} ... surface leakage current termination 1 (near end)
 I_{T2} ... surface leakage current termination 2 (far end)

Figure 61 Guard Ring connection technique with VSE box

The shown TD graph shows an example, where the termination had been cleaned properly. The relative humidity was very high. Only by means of the guard ring application, the real loss factor of the cable could be measured.

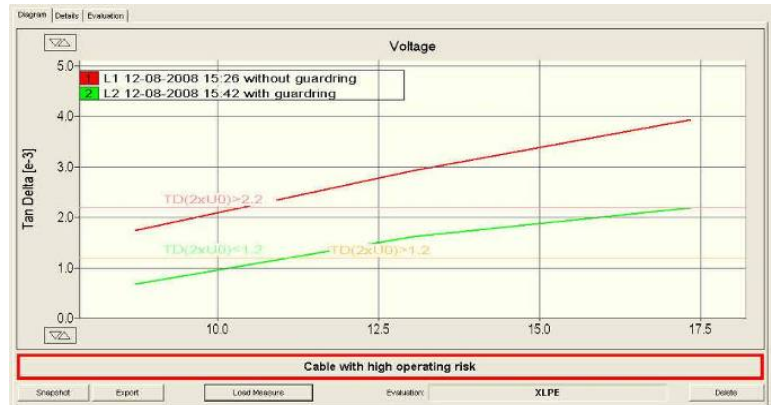

Figure 62 direct comparison of the TD value with guard ring application and without guard ring application

Figure 63, connection arrangement with guard ring and corona hoods (left), without guard ring (right); relative humidity 80%, 30°C

Figure 64, connection arrangement with guard ring and corona hoods, VSE box, Frida TD connection

7.6 Recommended approach for TD Evaluation

7.6.1 Loss factor measurement at XLPE cables

Evaluation criterions are defined in IEEE400.2-2013 [10]. The new guide differentiates between “service-aged” cables and newly installed cables.

For **service-aged** PE-based insulated cables, the applied voltage levels are defined with 3 steps from 0,5xU_o up to 1,5xU_o only. The VLF-TD criteria are defined at the middle value at 1,0U_o.

- If $\tan \delta$ measured at 1,0x U_o < 4×10^{-3} and difference of $\tan \delta$ measured at 1,5x U_o and 0,5x U_o is < 5×10^{-3} cable is in **good condition and “No Action required”**.
- If $\tan \delta$ measured at 1,0 x U_o > 50×10^{-3} or difference of $\tan \delta$ measured at 1,5x U_o and 0,5xU_o is > 80×10^{-3} cable is in **bad condition and “Action required”**

7.6.2 Loss factor measurement at PILC

Unlike for XLPE cables no single evaluation criterions exist for PILC cables because of different types of cable construction and insulation liquids are used. What is known by experience is that all 3 cores of a PILC cable should behave similarly and the increase of the $\tan \delta$ value of aged cables measured at 0,5 x U_o and 1,5 x U_o should be small.

Experience in European countries that have been using a lot of paper cables such as France, Spain and Portugal show, that absolute TD values up to 70×10^{-3} and differences of 10 to max. 20% between measurements at U_o and 2 x U_o are considered to be acceptable. Some of the utilities limit the max. value at 50×10^{-3} or even less. For highly aged circuits the applied voltage for TD Loss Factor measurement shall be limited to 0,5 x U_o to 1,5 x U_o which is similar to XLPE cables.

7.6.3 Loss factor measurement at mixed cable circuits:

Loss factor measurement results of mixed cable traces have to be evaluated in consideration of the length (capacity) relation between the XLPE part and PILC part. The loss factor of the PILC section, that is much higher than the loss factor of the XLPE section, is the most contributing factor.

For a rough calculation the capacity/km of XLPE and PILC can be considered same. As an example the loss factor measured for a cable circuit consisting 50% of XLPE and 50% of PILC is half the value of the PILC part. ($\tan \delta = 1/(\omega * C * R)$).

If the XLPE section is twice the PILC section loss factor measured is 1/3 of the loss factor of the paper section and vice versa.

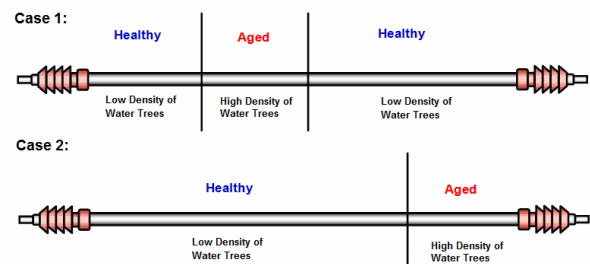

Figure 65 Some possible cases for a cable section with non-uniform water tree degradation [17]

7.6.4 Viewing points / Definitions used for evaluation:

- „1.5U₀ mixed cable evaluation“ evaluation criteria applied for **mixed cables**
- „1.5U₀ XLPE cable evaluation“ evaluation criteria applied for **XLPE and WTP-XLPE cable (Water Tree Prone Cables)**
- Average value ... following IEEE 400.2-2013 [10]
- Delta Tan Delta DTD ... following IEEE 400.2-2013 [10]
- Standard Deviation / Stability ... following IEEE 400.2-2013 [10] & BAUR TD diagnostic guidelines V4 03.2013 [19]
- TD Trend analysis ... BAUR TD diagnostic guidelines V4 03.2013 [19]

Standard Deviation / Stability is handled according to BAUR’s internal “tan delta diagnostic-guidelines V4 03.2013”. The mentioned values are closely correlating to IEEE400.2-draft 12 (Jan. 2012) and the new field guide IEEE400.2-2013.

Extract IEEE400.2-2013, Table I.1 for XLPE (outside North America) or New Cables

Condition Assessment	TD Stability (measured by standard deviation) at U ₀ [10 ⁻³]		Differential TD (difference in mean TD) between 2.0U ₀ and U ₀ [10 ⁻³]		Mean TD at 2U ₀ [10 ⁻³]
No Action Required	<0.1	And	<0.6	And	<1.2 to <2,2
Further Study Advised	0.1 to 0.5	Or	0.6 to 1	Or	1.2 to 2
Action Required	>0.5		>0.6 or >1		>2.2

Table 7, IEEE400.2-2013 for XLPE cables 1.0 - 2.0 U₀ [10, p. 48]

The mentioned values stated in the IEEE400.2-2013 (Table I.1) are for TD measurement from 1.0U₀ to 2.0U₀. As the main studies of practical results were focused on power utilities in North America, IEEE summarizes the above criteria as “outside North America”. Wide experience of BAUR supports that the IEEE400.2-2013 values that are defined for America can also be applied worldwide very well.

Extract IEEE400.2-2013, Table I.4 for paper insulations PILC, also applicable for Mixed Cables

Condition Assessment	TD Stability (measured by standard deviation) at U_0 [10^{-3}]		Differential TD (difference in mean TD) between $2.0U_0$ and U_0 [10^{-3}]		Mean TD at $2U_0$ [10^{-3}]
No Action Required	<0.5	And	-20 to 20	And	<50
Further Study Advised	0.5 to 1	Or	-20 to -50 or 20 to 50	Or	50 to 100
Action Required	>1		< -20 or >50		>100

Table 8, IEEE400.2-2013, International figures for PILC cables (1.0U₀ to 2.0U₀) [10, p. 49]

Adapted Evaluation Criteria for TD measurements from 0.5U₀ to 1.5U₀:

Condition Assessment	TD Stability (measured by standard deviation) at U_0 [10^{-3}]		Differential TD (difference in mean TD) between $1.5U_0$ and $0.5 U_0$ [10^{-3}]		Mean TD at $1.5U_0$ [10^{-3}]
No Action Required	<0.1	And	<0.6	And	<1.2 to <2,2
Further Study Advised	0.1 to 0.5	Or	0.6 to 1	Or	1.2 to 2
Action Required	>0.5		>0.6 or >1		>2.2

Table 9, Adjusted table I.1 of IEEE400.2-2013 acc. to BAUR experience for 0.5U₀ to 1.5U₀ XLPE Cables

The values from IEEE 400.2-2013 for new XLPE are directly applied to measurement values from 0.5U₀ to 1.5U₀. Marginal differences are not considered.

Applied evaluation criteria:

Name of Evaluation XLPE 1,5U₀

Criterion	Comment
TD(1.0xU ₀)>2.2	Cable with high operating risk
TD(1,5xU ₀)-(0.5U ₀)>1.0	Cable with high operating risk
TD(1.0xU ₀)>1.2	Highly service aged cable
TD(1.0xU ₀)<1.2	Cable can be returned to service
TD(1.5xU ₀)-(0.5U ₀)<0.6	Cable can be returned to service

Condition Assessment	TD Stability (measured by standard deviation) at U_0 [10^{-3}]		Differential TD (difference in mean TD) between $1.5U_0$ and $0.5U_0$ [10^{-3}]		Mean TD at $1.5U_0$ [10^{-3}]
No Action Required	<0.5	And	-10 to 10	And	<50
Further Study Advised	0.5 to 1	Or	-10 to -20 Or 10 to 20	Or	50 to 70
Action Required	>1		< -20 or >20		>70

Table 10, Adjusted table I.4 of IEEE400.2-2013 acc. to BAUR experience for 0.5U₀ to 1.5U₀ PILC & Mixed Cables

Applied evaluation criteria

Name of Evaluation PILC, mixed 1,5U₀

<i>Criterion</i>	<i>Comment</i>
TD(1.0xU ₀)>70.0	Cable with high operating risk
TD(1.5xU ₀)-(0.5xU ₀)>20.0	Cable with high operating risk
TD(1.0xU ₀)>50.0	Cable highly service aged
TD(1.5xU ₀)-TD(0.5xU ₀)>10.0	Cable highly service aged
TD(1.0xU ₀)<50.0	Cable can be returned to service
TD(1.5xU ₀)-TD(0.5xU ₀)<10.0	Cable can be returned to service

7.6.5 TanDelta as measuring tool for humidity in cable accessories

VLF TD Hysteresis at voltage rise and voltage decay

A new TD effect was found in 1999, using VLF delta TD at increasing voltage over time to locate bad mounted accessories. Brincourt et al. EDF, France and NEETRAC could clearly prove water or humidity ingress in accessories using a delta TD method.

Decreasing TD values at rising voltage is usually caused by humidity which can evaporate in a short time. As a consequence, the drying out effect becomes measureable within a short time - usually in one or two minutes. If the TD measurement is used with increased and with decreased voltage levels, a TD hysteresis can be correlated with higher moisture content in the insulation.

The probability of bad mounted joints and water ingress can be assumed. In many practical cases a TD measurement before and after replacement of joints can solve the problem.

Internally, in the cable insulation embedded moisture defects are showing very small or no hysteresis effects. Since long time stress with HV to the already degraded insulation is not appreciable, a new practice of TD hysteresis methodology was introduced by BAUR.

The hysteresis of dissipation factor is evaluated by using a VLF voltage rise and decay in a single process Figure 66. [1]

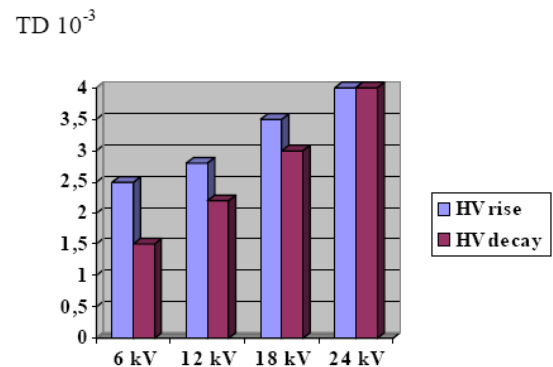

Figure 66 Hysteresis of dissipation factor TD at VLF voltage rise and voltage decay [1]

TD values on other type of insulations like PILC, EPR, TR-XLPE, Co-Polymers are showing other start up (new) TD levels, they develop in respect of ageing, however, very similar to XLPE. Individual criteria levels for each type of insulation and TD comparison between phases are very helpful tools for qualification.

The TD stability evaluation delivers further very informative indications. Negative stability trend indicate small amount of water ingress in joints or humidity influence at terminations. Additionally, negative DTD (Delta Tan Delta) behaviour indicates less leakage influence over time. High amount of water ingress in joints may not necessarily be influenced by the applied voltage during the TD measurement. High fluctuations of the TD value throughout each of the voltage steps are the only significant indicator.

7.6.6 Newly implemented Evaluation Criteria for TanDelta Loss Factor Measurement acc. to IEEE 400.2-2013

Annex I: Tan Delta Criteria Used Outside North America [10, p. 48]

Tables 4 to 6 in this guide are based on data obtained on North American cable designs and installations.

Tables I.1, I.2, I.3 and I.4 list the ranges in the TD assessment criteria for different cable insulations used in different countries outside North America by industry and utilities. Lower and upper TD and differential TD limits are individually applied. The number of utilities or countries is not known and no information is available about failure occurrences or service conditions.

Table I1: Alternate figures of merit for condition assessment of PE-based insulations (i.e. PE, XLPE) TD Measurement up to 2U₀

Condition Assessment	TD Stability (measured by standard deviation) at U ₀ [10 ⁻³]		Differential TD (difference in mean TD) between 2U ₀ and U ₀ [10 ⁻³]		Mean TD at 2U ₀ [10 ⁻³]
No Action Required	<0.1	And	<0.6	And	<1.2 to <2,2
Further Study Advised	0.1 to 0.5	Or	0.6 to 1	Or	1.2 to 2
Action Required	>0.5		>0.6 or >1		>2.2

Table I2: Alternate figures of merit for condition assessment for PE-with additives based insulations (i.e. TRXLPE, Co-Polymers) ¹⁾ TD Measurement up to 2U₀

Condition Assessment	TD Stability (measured by standard deviation) at U ₀ [10 ⁻³]		Differential TD (difference in mean TD) between 2U ₀ and U ₀ [10 ⁻³]		Mean TD at 2U ₀ [10 ⁻³]
No Action Required	<0.5	And	<1.5	And	<8
Further Study Advised	0.5 to 1	Or	1.5 to 3	Or	8 to 10
Action Required	>1		>3		>10

1) Note: Due to a long term polymerization effect the mean TD results at 2U₀, immediately after production of Co-Polymers insulations may be measured significantly higher. After one or two years the absolute TD values may decrease close to levels similar to XLPE or PE insulations.

Table 11, Table I1/I2 IEEE400.2-2013, [10, pp. 48-49], ANNEX I, Evaluation criteria for outside North America

Table I3: International figures of Insulations (i.e. EPR) - TD Measurement up to 2U₀

Condition Assessment	TD Stability (measured by standard deviation) at U ₀ [10 ⁻³]		Differential TD (difference in mean TD) between 2U ₀ and U ₀ [10 ⁻³]		Mean TD at 2U ₀ [10 ⁻³]
No Action Required	<0.5	And	<4	And	<10
Further Study Advised	0.5 to 1	Or	4 to 10	Or	10 to 80
Action Required	>1		>10		>80

Table I4: International figures for Condition of Paper Insulations (i.e. PILC) - TD Measurement up to 2U₀

Condition Assessment	TD Temporal Stability (measured by standard deviation) at U ₀ [10 ⁻³]		Differential TD (difference in mean TD) between 2U ₀ and U ₀ [10 ⁻³]		Mean TD at 2U ₀ [10 ⁻³]
No Action Required	< - 0.5	And	-20 to 20	And	<50
Further Study Advised	0.5 to 1	Or	-20 to -50 or 20 to 50	Or	50 to 100
Action Required	>1		< - 50 or > 50		>100

Table 12, Table I3/ I4, IEEE400.2-2013, [10, pp. 48-49], ANNEX I, Evaluation criteria for outside North America

Furthermore, IEEE400.2-2013 states different criteria that shall apply for cable network according to the special experience based on mainly NEERTRAC for the cable types used in North America. As the research focused mainly in the North America market, these values might not fully adapt for other countries.

Table 4: Historical figures of merit for condition assessment of service-aged PE-based Insulations (i.e. PE, XLPE, and TRXLPE) using 0.1 Hz - TD Measurement up to 1.5U₀

Condition Assessment	VLF-TD Time Stability (VLF-TDTS measured by standard deviation) at U ₀ [10 ⁻³]		Differential VLF-TD (VLF-DTD) (difference in mean VLF-TD) between 0.5 U ₀ and 1.5 U ₀ [10 ⁻³]		Mean VLF-TD at U ₀ [10 ⁻³]
No Action Required	< 0.1	and	< 5	and	< 4
Further Study Advised	0.1 to 0.5	or	5 to 80	or	4 to 50
Action Required	> 0.5	or	> 80	or	> 50

Table 13, Table 4, IEEE400.2-2013[10, p. 19] – Evaluation Criteria for service aged PE-based insulation

Table 5: Historical figures of merit for condition assessment of service-aged filled insulations (i.e. EPR & Vulkene)¹ using 0.1 Hz - TD Measurement up to 1.5U₀

Condition Assessment	Filled Insulation System	VLF-TD Time Stability (VLF-TDTS measured by standard deviation at U ₀) [10 ⁻³]		Differential VLF-TD (VLF-DTD) (difference in mean VLF-TD) between 0.5 U ₀ and 1.5 U ₀ [10 ⁻³]		Mean VLF-TD at U ₀ [10 ⁻³]
No Action Required	* If it is not possible to definitively identify a Filled Insulation	<0.1	A N D	<5	A N D	<35
	Carbon Filled (Black) EPR	<0.1		<2		<20
	Mineral Filled (Pink) EPR	<0.1		<4		<20
	** Discharge Resistant EPR	<0.1		<6		<100
	** Mineral Filled XLPE	-		-		<100
Further Study Advised	* If it is not possible to definitively identify a Filled Insulation	0.1 to 1.3	or	5 to 100	or	35 to 120
	Carbon Filled (Black) EPR	0.1 to 2.7		2 to 120		20 to 100
	Mineral Filled (Pink) EPR	0.1 to 1		4 to 120		20 to 100
	** Discharge Resistant EPR	0.1 to 1		6 to 10		100 to 350
	** Mineral Filled XLPE	-		-		100 to 350
Action Required	* If it is not possible to definitively identify a Filled Insulation	>1.3	or	>100	or	>120
	Carbon Filled (Black) EPR	>2.7		>120		>100
	Mineral Filled (Pink) EPR	>1		>120		>100
	** Discharge Resistant EPR	>1		>10		>350
	** Mineral Filled XLPE	-		-		>350

* Experience has shown that it is quite difficult to precisely identify the type of filled insulation of field-installed cable. The issues encountered include: incorrect or missing records, obliterated or obscured markings on the cable jacket, indistinct colouring etc. In these cases it is recommended to use the criteria for the collated data sets.

** Insufficient data have been collected to make precise estimates of criteria, consequently the criteria are likely contain considerable errors, see Appendix G. However they are included here to provide some guidance to engineers encountering these insulation systems in the field.

Table 14, Table 5, IEEE400.2-2013 [10, p. 20] - Evaluation Criteria for service aged filled cables (EPR's)

Very similar values in a simplified version can be found in „Aging Management Program Guidance for Medium Voltage Cable Systems for Nuclear Power Plants” prepared by the Electric Power Research Institute through an interactive Technical Advisory Group review process. [20]

Table 5-1
Preliminary Tan δ Assessment Criteria for Butyl Rubber (in terms of $\times 10^{-3}$; 0.1 Hz test frequency) (Note 1)

Condition	Tan δ		Absolute Value of the Difference in Tan δ Between 0.5 V_0 and 1.5 V_0 (Notes 2 and 3)
Good	≤ 12	and	≤ 3
Further study required	$12 < \tan \delta \leq 50$	or	3+ to 10
Action required	> 50	or	$> 10+$

Notes:
 1. This is based on Figure C-13 in EPRI report *Plant Support Engineering: Medium-Voltage Cable Aging Management Guide* (1016689) [15] and in-plant test results and consultation with tan δ testers.
 2. Differentials may be taken at 1 V_0 and 2 V_0 at the user's option. See text preceding this table.
 3. The difference in tan δ is normally positive. Negative differences should be treated as very significant and may indicate a problem with a test or an indication of the presence of a significant defect.

Figure 67 Table 5-1 - EPRI TanDelta Assessment Criteria for EPR Butyl Rubber cables [20]

Table 5-2
Preliminary Tan δ Assessment Criteria for Black EPR (in terms of $\times 10^{-3}$; 0.1 Hz test frequency) (Note 1)

Condition	Tan δ		Absolute Value of the Difference in Tan δ Between 0.5 V_0 and 1.5 V_0 (Notes 2 and 3)
Good	≤ 12	and	≤ 3
Further study required	$12 < \tan \delta \leq 50$	or	3+ to 10
Action required	> 50	or	$> 10+$

Notes:
 1. This is based on Figure C-1 in EPRI Report 1016689 [15] and associated in plant results and consultation with tan δ testers.
 2. Differentials may be taken at 1 V_0 and 2 V_0 at the user's option. See text preceding these tables.
 3. The difference in tan δ is normally positive. Negative differences should be treated as very significant and may indicate a problem with a test or an indication of the presence of a significant defect.

Figure 68 Table 5-2 - EPRI TanDelta Assessment Criteria for Black EPR cables [20]

Table 5-3
Preliminary Tan δ Assessment Criteria for Pink EPR (Note 1) (in terms of $\times 10^{-3}$; 0.1 Hz test frequency) (Note 2)

Condition	Tan δ		Absolute Value of the Difference in Tan δ Between 0.5 V_0 and 1.5 V_0 (Notes 3 and 4)
Good	≤ 15	and	≤ 3
Further study required	$15 < \tan \delta \leq 30$	or	3+ to 8
Action required	> 30	or	$> 8+$

Notes:

1. This may also be used for "Gray" UniBlend® EPR (approximate time of manufacture from late 1970s on).
2. This is based on Figures C-3 and C-4 in EPRI Report 1016689 [15] and consultation with tan δ testers.
3. Differentials may be taken at 1 V_0 and 2 V_0 at the user's option. See text preceding these tables.
4. The difference in tan δ is normally positive. Negative differences should be treated as very significant and may indicate a problem with a test or an indication of the presence of a significant defect.

Figure 69 Table 5-3 - EPRI TanDelta assessment criteria for Pink EPR cables [20]

Table 5-4
Preliminary Tan δ Assessment Criteria for Brown EPR (in terms of $\times 10^{-3}$; 0.1 Hz test frequency) (Note 1)

Condition	Tan δ		Absolute Value of the Difference in Tan δ Between 0.5 V_0 and 1.5 V_0 (Notes 2 and 3)
Good	≤ 50	and	≤ 5
Further study required	$50 < \tan \delta \leq 60$	or	5+ to 15
Action required	> 60	or	$> 15+$

Notes:

1. This is based on Figures C-3 and C-4 in EPRI Report 1016689 [15] and consultation with tan δ testers.
2. Differentials may be taken at 1 V_0 and 2 V_0 at the user's option. See text preceding these tables.
3. The difference in tan δ is normally positive. Negative differences should be treated as very significant and may indicate a problem with a test or an indication of the presence of a significant defect.

Figure 70 Table 5-4 - EPRI Tan Delta assessment Criteria for Brown EPR cables [20]

Further information on TanDelta evaluation criteria could be found IEEE400.2/D11 but was removed in the later stage of D12 due to not sufficient data.

Table 7: Historical figures of merit for condition assessment of service-aged paper insulations (i.e. PILC) using 0.1 Hz - TD Measurement up to 1.5U₀

Condition Assessment	VLF-TD Time Stability (VLF-TDTS measured by standard deviation at U ₀ [10 ⁻³])		Differential VLF-TD (VLF-DTD) (difference in mean VLF-TD) between 0.5 U ₀ and 1.5 U ₀ [10 ⁻³]		Mean VLF-TD at U ₀ [10 ⁻³]
No Action Required	<0.1	and	-35 to 10	and	< 85
Further Study Advised	0.1 to 0.4	Or	-35 to - 50 or 10 to 100	or	85 to 200
Action Required	>0.4	or	< - 50 Or > 100	Or	> 200

The condition assessment for the cable system may be undertaken by considering the VLF-TD characteristics in the sequence VLF-TD Temporal Stability then Differential VLF-TD and finally Mean VLF-TD. The Condition assessment is given by the most serious condition of any of the features. Any prioritization or extra differentiation between tested cable system portions may be accomplished by looking at the assessments for different features. Examples of condition assessment of cable systems are shown in Table 7 of [10]

Table 15, Table 7, page 21, IEEE400.2-2013 [10, p. 21] - Evaluation Criteria for service aged PILC cables

Note: for DTD in PILC cables

Figure 5 of [21] shows the distribution of Tip Up data for different ranges of Tip Up where Tip Up is the difference in Tan Delta measured at 1.5U₀ and 0.5U₀. As many workers have noted, it is quite common for PILC cables to show a negative Tip Up, however excessive negative values have been considered atypical in the same manner as unusual large ones.

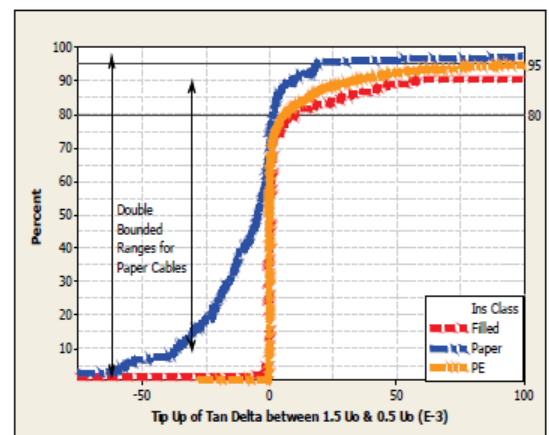

Figure 5: Cumulative Distribution of all Cable System Tip Up Criteria – scale has been expanded to show negative Tip Up on the Paper cables

Figure 71 TD Tip Up distribution in Filled, PILC and PE cables [21]

8 PD Partial Discharge Localization and Level Measurement

8.1 Background



Figure 72 BAUR PHG 70/80 TD PD

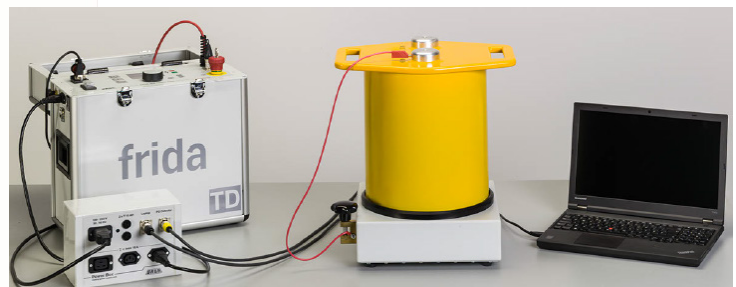

Figure 73 BAUR Frida TD + PD TaD 60

Using partial discharge measurement with source localization, direct allocation of partial discharge activity on cable segments, joints or cable terminations is possible. The partial discharge measurement is based on a VLF truesinus[®] voltage waveform.

The travelling partial discharge pulses are subject to the damping of the cable. Therefore the level to be measured is dependent on the distance from the end to the partial discharge source. For partial discharge source location only the time delay between the first and the reflected pulse is important.

In XLPE cables the partial discharge source is not located in the cable insulation itself, but in the accessories. Would the partial discharge source be located within the cable insulation, this would lead to a breakdown within shortest time (stage of electrical tree) during normal operation. Practical measurement had proven that most of the partial discharge sources are located in the joints. Partial discharge sources outside the joints are rare and in those cases mostly defects on the sheath.

This leads to the fact that for on-site partial discharge diagnostic partial discharge levels in the range of some 100 pC are relevant only. Most important is the knowledge of the location of the partial discharge source.



Figure 74 PD Localization Graph of a XLPE cable with 3 joints with PD activity

8.2 Partial discharge measurement according to IEC 60270

The conventional measurement of partial discharges according to IEC 60270 (High-voltage test techniques – Partial discharge measurement) the partial discharge measurement is performed at the cable end.

Partial discharges inside the cables cause a short term breakdown of the cable insulation. The thereby caused pulse-shaped recharging current is detected at the coupling capacitor over the measurement unit (quadripole) - in parallel to the cable - and converts it into a equivalent voltage signal. This voltage signal is then recorded by the partial discharge detection system and monitored as an impulse on the monitor.

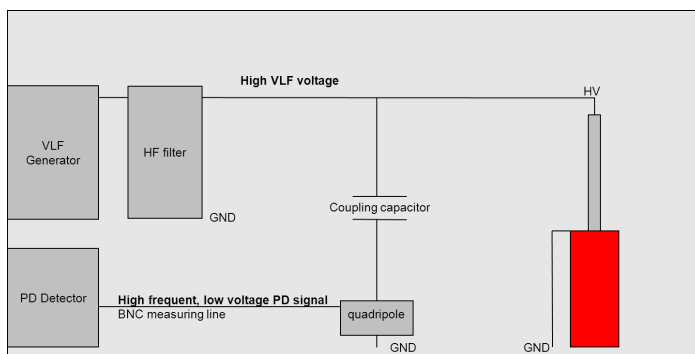

Figure 76 Test setup of BAUR VLF PD System

Figure 75 PD portable connection diagram

Test Setup

- VLF Generator generation of symmetrical sine-wave voltage (truesinus®), frequency 0.1Hz
- HF Filter filtering of generator caused HF disturbance (e.g. from power electronic components)
- Coupling capacitor & quadripole detection of recharging current and conversion into equivalent voltage signal
- PD detector recording of PD discharge events and signal processing for graphical display

Theory of the PD detection

Diagnostic on PE/XLPE and PILC cables

The VLF test and ageing diagnosis at PE / XLPE cables by means of dissipation factor measurement are the criteria, on which the assessment of energy cables can be based. The partial discharge measurement with localisation of the partial discharge source closes the gap in the insulation diagnostics of PILC and assures the assessment of plastic cables.

With the withstand test a pure „go/no go“ statement about the actual expanded dielectric strength of the weakest point within a cable system is made. It is carried out after laying, after repairs or at service aged cables to prove the operational safety.

Diagnostic via VLF dissipation factor measurement delivers information about the global ageing condition of plastic cables.

The partial discharge measuring method provides reliable information on whether there are installation errors or electrical trees on plastic cables that have not yet caused a breakdown.

It can be estimated whether a dissipation factor measurement was possibly influenced by intensive partial discharges (for example in joints).

Using partial discharge measurement with source localisation, direct allocation of partial discharge activity on cable segments, joints or cable terminations is enabled. The person responsible is thus in the position to take preventive measures and thus avoid local faults in the plant.

Beside the application on cables, partial discharge level measurements of other samples is also possible.

The partial discharge level measurement can be implemented into the PHG TD system which then forms the cable test and diagnostic system PHG TD/PD. All important cable data can be stored in the program, so that step-by-step

a cable database is created which enables to make the operational evaluation of the diagnostic results on the basis of the historical evolution of a cable system.

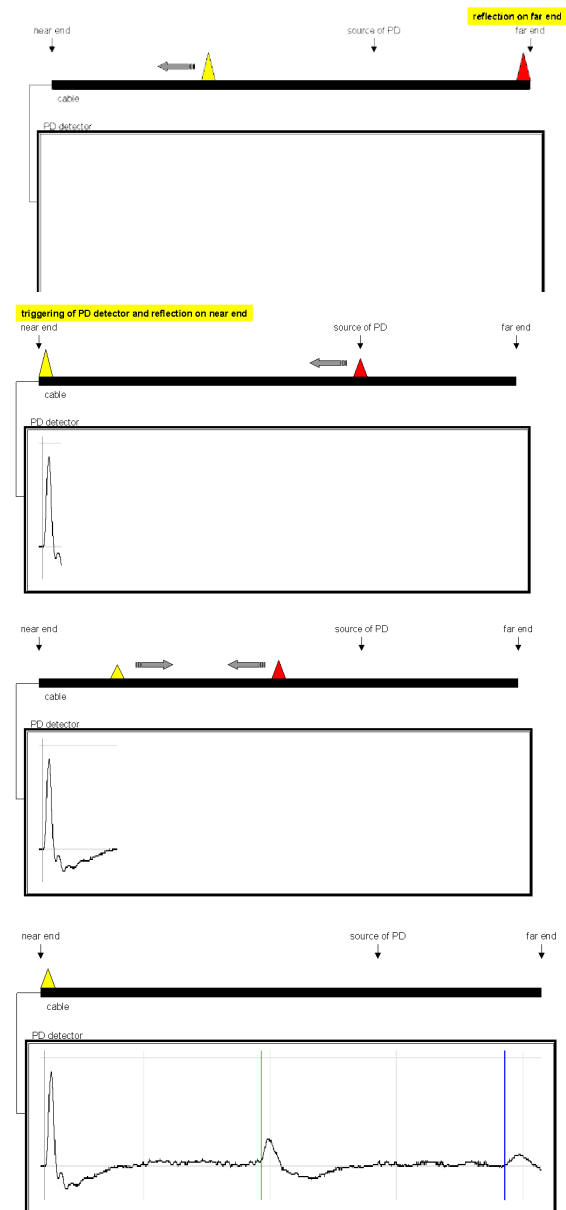

Figure 77 Sequence of graphical PD pulse localization

Experience on paper mass impregnated cables PILC

The PD measurement on paper mass cables in regards to the measuring technique is the same as on XLPE cables. The most important difference exists in the interpretation of the results. From its design a paper mass impregnated cable has a lot of PD activities within its insulation. In comparison to a XLPE cable this is not harmful to the insulation.

The voids in the insulation open and close frequently due to the thermal expansion and viscosity of the insulation mass. The harmlessness of this characteristic is proven by paper mass cables showing nC- values (Figure 78 shows up to 5000pC) of PD but being in operation since more than 80 years. This background PD level of the cable itself depends on type, manufacturer, manufacturing year and condition of the cable and ranges between some 10 pC and some 1000pC without being risky to the cable's service reliability.

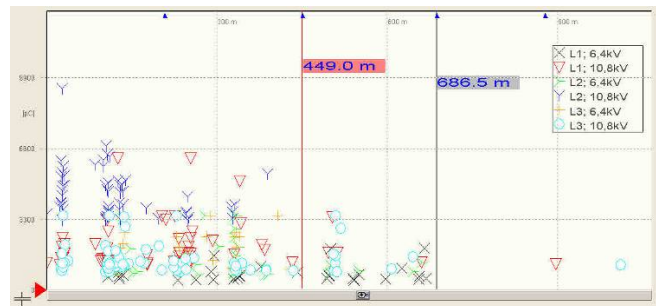

Figure 78 typical example of scattered PD activity along a PILC section

As already described for the XLPE cables, the PD measurement at paper mass cables is done in order to **locate defects in joints and terminations** as well as the cable itself. In some cases defects of the sheath (corrosion of the lead sheath) were detected. In comparison to XLPE cables, the paper mass cables were never routine PD tested at the manufacturer. Therefore the interpretation of the results and the operation risk are much more difficult compared to XLPE cables.

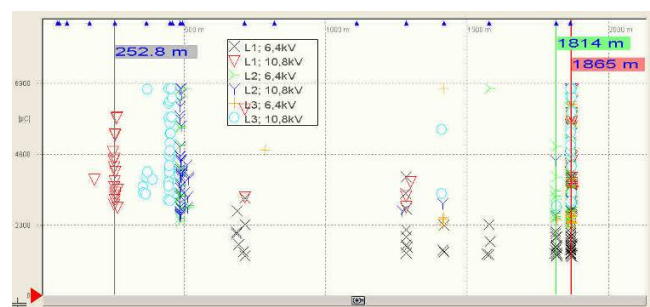

Figure 79 typical example of a XLPE cable with multiple joints showing PD activity

Only **comparison** between the cables of different phases and of same type and manufacturing year enable an clear interpretation. Additionally the measurement itself is more difficult. Many of the (non-risky) discharges in the cable are recorded by the measurement system. Each impulse shows the equivalent position of the source. This leads to a distribution of many pulses all over the cable length. In order to locate a defect which shows up with a PD level higher than this „scattered activity“, many recordings are required. Measurement systems with automatic position recognition are to be favoured. Practical experience of utilities in Germany, Austria, Italy, Russia, Ukraine and other countries have shown, that despite of the above described difficulties a reliable identification of PD sources in PILC as well as mixed cables is possible. Even sheath defects could be identified. In addition frequent lead corrosion at railway crossings and river crossings areas had been detected.

Therefore PD location and measurement on PILC cables is even highly recommended in order to increase the reliability of the grid.

8.3 Calibration

IEC 60270 defines to perform an onsite calibration for each test. As the measured partial discharge charge is damped in amplitude - due to traveling along the length of the cable – and needs to be corrected by a damping factor to detect the apparent charge Q_a . Thereby a known charge (calibration charge in pC) is send into the test-setup. Out of the recorded graph the cable length and charge can be measured.

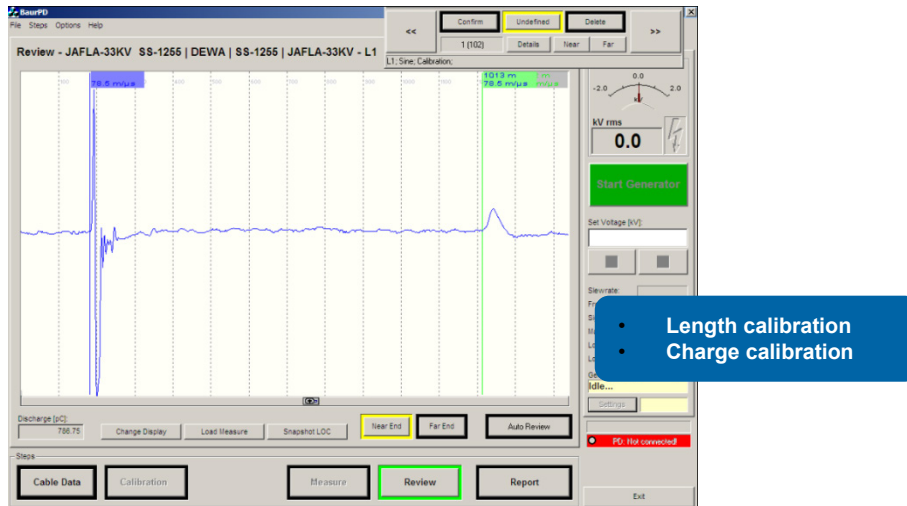

Figure 81 Screenshot of BAUR PD software - Calibration graph

Figure 80 PD coupler CU60 with Calibrator

8.4 Make use of the calibration graph

PD Calibration graph as tool to identify jointpositions:

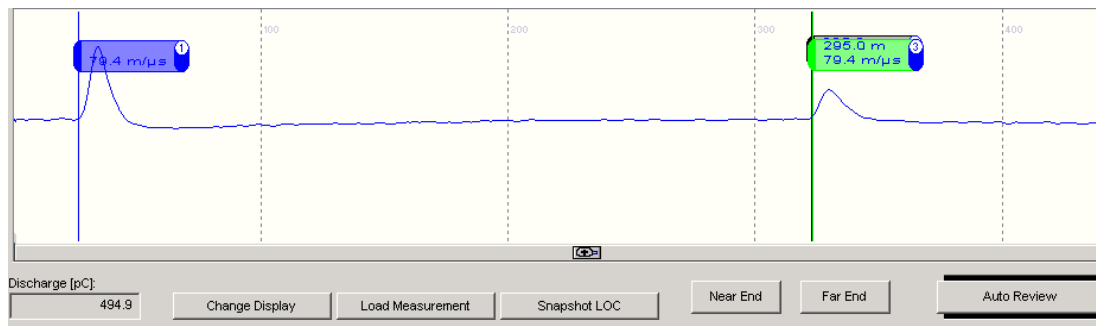

Figure 82 Calibration graph of a cable with 295m without any joint

The calibration sequence is part of every PD measurement on site. The calibration graph is a very helpful tool to identify joint positions.

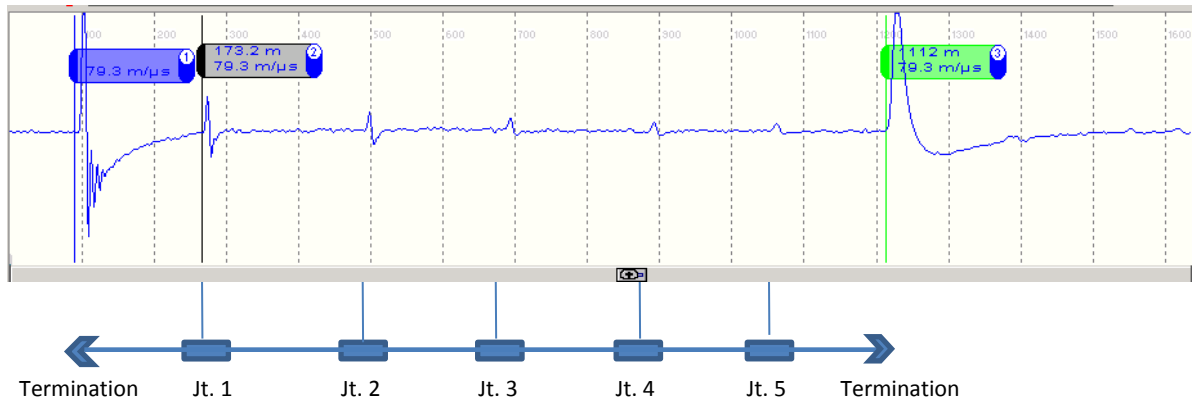

Figure 83 Calibration graph of a new XLPE cable with 6 equal sections and 5 joints

Further detailed graph characteristics have been elaborated in detail by NEETRAC. [22] According to these findings, calibration graphs that are basically TDR graphs and can be used to identify the characteristic of a joint in dependance of it's pulse pattern. [22]

3.2.4 Success Criteria

Typical waveforms and their meaning appear in Table 11. The actual appearance of the waveforms varies and will not exactly match those shown in references. Therefore, there are no unified success criteria for TDR testing.

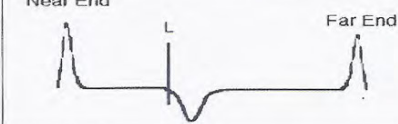
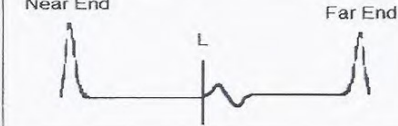
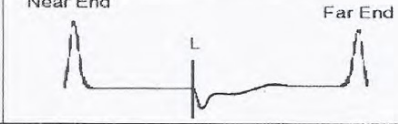
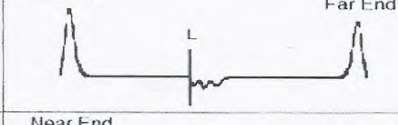

Table 11: Cable Conditions Distinguishable using TDR [64]	
Case	TDR
Uniform cable segment with no joints.	
Uniform cable segment with no joints and shorted conductor at distance L from Near End.	
Cable segment with a joint at a distance L from Near End.	
Cable segment with a wet joint at a distance L from Near End.	
Uniform cable segment with water ingress at a distance L from Near End.	
Uniform cable segment with localized corroded neutrals at a distance L from Near End.	

Figure 84 Table 11 of, TDR graph interpretation to identify cable conditions [22]

Examples for detection of joints with irregular characteristic

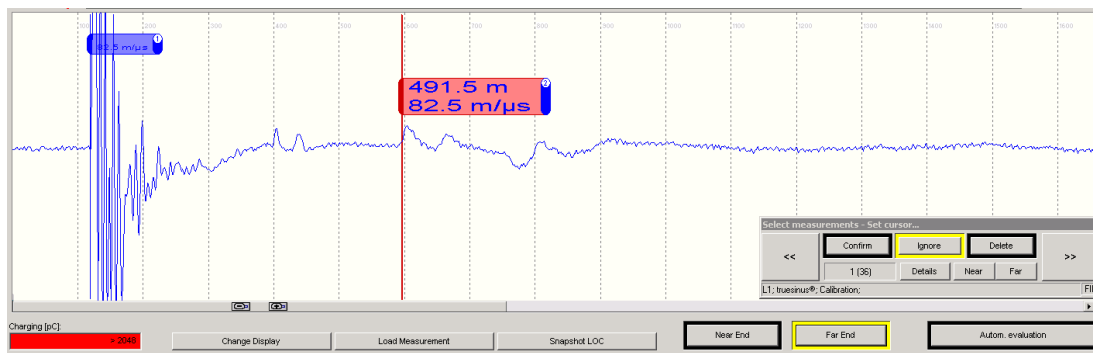

Figure 85 calibration graph with identification of several joints. e.g. 491.5m

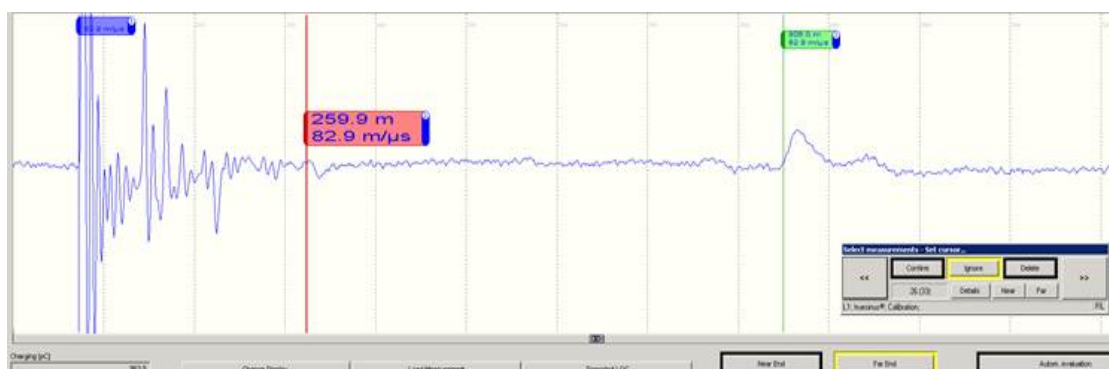

Figure 86, calibration graph with identification of a joint with water ingress at 260m.

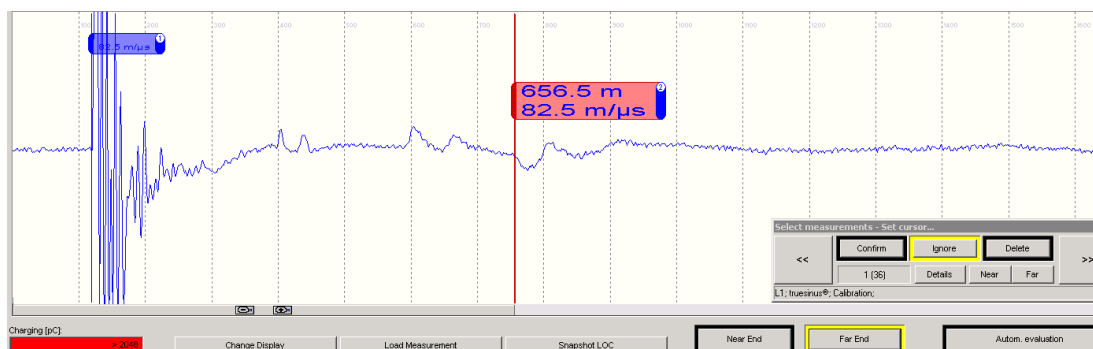

Figure 87, calibration graph with identification of joint with water ingress at 656.5m

TDR analysis is a widely adapted method for fault location. The equipment is light weight and the test time is short. PD diagnostic procedure includes the calibration stage. A calibration pulse is comparable to a TDR impulse. However, there are open issues about this method. The historical data for TDR analysis is to be further studied in order to give confident judgment. The TDR pulse is a low voltage pulse, which are influenced by cable length, high number of joints as well as high noise environment. Operators' skills are required to differentiate between regular impedance changes that are caused by transition joint and irregular impedance changes caused by water ingress. Careful evaluation and interpretation is essential to prevent incorrect judgments.

8.4.1 Partial discharge measurement at VLF and other test voltage waveforms

The VLF PD mapping and PD fault location under field conditions have been in practice for over 10 years.

In 2007, a benchmark test with **different HV waveforms**, on different artificial defects made at RWE EUROTEST in Germany, is showing **non-uniform results** [19]. Interpretations of the PD magnitude and quantity results are incomparable [9]. [23]

Key questions and challenges:

- The users do not have knowledge rules to quantify the level of different type of damages.
- The magnitude does not indicate a severe damage or a less dangerous situation in the cable insulation.
- It is usually not possible to predict possible failures if the cables are not tested up to the breakdown.
- Single spot defects are easily located by using impulse time domain techniques.
- PD magnitude does not always correlate with the highest or most dangerous defect since the type of fault is usually unknown.
- Only historical data might lead to better decisions for replacement or repair process.

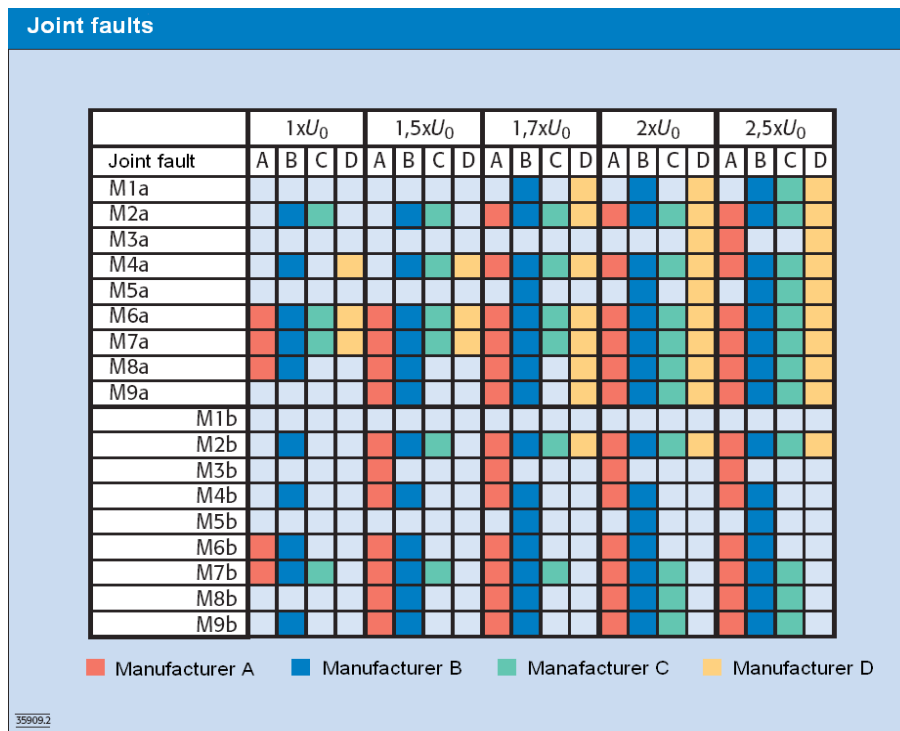

Manufacturer A:	BAUR VLF PD system
Manufacturer B:	50Hz sinewave test equipment (laboratory equipment)
Manufacturer C:	Oscillating voltage near the operating frequency, 50Hz , high attenuation
Manufacturer D:	Oscillating voltage of variable frequency with low attenuation

Figure 88 Matrix of all the measurements performed on the model faults in joints (the boxes with a colour background indicate detected and localized discharge activity) [23]

Based on the questions and challenges nine different PD sources were created and investigated from both cable ends by different techniques.

As seen in Figure 88, all model faults in the joints except M1b can be detected with the aid of the partial discharge measurement. However, the localization rate varies significantly between the various measuring systems. It can be seen that the partial discharge activity increases with increasing test voltage and therefore the detection of a possible fault is made easier. The distribution of the coloured boxes also shows that the test voltage shape has a significant effect on the initiation of a partial discharge. It can also be seen that the detection rate for measurements from the end furthest away from the fault (M1b to M9b) is lower than for measurements from the end near the fault (M1a to M9a).

As general summary, the VLF PD measurement technique used by BAUR shows the closest ability to detect all kind of PD sources compared to the 50Hz PD detection systems that are used in laboratories. Oscillating voltage (at 50Hz and damped oscillating wave) show big deviations in the ability to detect weaknesses in many types of joints.

Further details can be found in the full report [23] (Comparison of available measuring methods, RWE-Eurotest).

8.5 Advantages of VLF PD Diagnostic

- Continuous measurement of Partial Discharge and TanDelta **during a standard test procedure** can be carried out over specified time periods (MWT- Monitored Withstand Test). **Repeatable test conditions** to evaluate PD inception and PD extinction voltage characteristic.
- Calibration according to IEC 60270.
- **Length independent measurement of PD level**
- Highest accuracy in PD location
- PD monitoring over a **definable time span** enables to detect PD sources that are only starting after a certain time of application of high voltage
- PD measurement **during commissioning test** with VLF testing voltage (MWT)
- **PD location pinpointing** for reconfirmation of prelocated location in the field
- **Reproducible PD level and location measurement**
- PD measurement **independent on calibration charge value**
- **Automatic** as well as manual PD result **evaluation**



Figure 89 Portable on-site PD detector with PD location (BAUR PD portable)

8.6 PD Inception (PDIV) and PD Extinction (PDEV) voltage

The characteristic of a partial discharge source is defined by its inception and extinction voltage.

The PD inception voltage (PDIV) is defined as the voltage level where the PD activity is started. This value is most important. In general it is important to know, whether a PD source is active at nominal voltage U_0 what equals to the nominal operation voltage. If the PDIV is lower or at U_0 (Phase to Ground Voltage) the PD source is active during normal service operation of the cable.

In such a case the partial discharge is **continuously active and permanently damaging the insulation**. In dependence of the spot, the insulation material surrounding the location might be more or less resistant to the continuous sparking. As the PD activity is causing the development of heat and carbonisation, PD sources with PDIV at or below U_0 are to be treated as serious threat to the reliability of the cable performance.

In comparison a PDIV above U_0 has to be handled in a different way. Under normal operation voltage this PD source will not be active. Certain switching cycles or short term fault conditions may raise the operation voltage to the PDIV temporarily.

In regard to this condition, it is important to consider the PDEV-level.

The PD extinction voltage (PDEV) is defined as voltage level where the PD source stops its PD activity. Certain PD sources show characteristics where the **PDEV is lower compared to the PDIV**. If the PDIV is only slightly above U_0 a switching sequence, where the voltage is increasing temporarily, may initiate the PD activity. If the PDEV is below U_0 this kind of PD source may stay active also after the network voltage reaches back to the nominal U_0 voltage level again. Such kinds of PD sources have to be treated seriously but are very rare.

8.7 PD result interpretation – guidelines

8.7.1 PD measurements at XLPE cables

In XLPE and EPR cables PD activities mainly occur in cable accessories. PD in the XLPE insulation itself can be detected very rarely. If PD occurs in the XLPE insulation (electrical treeing) the cable will fail within a few days or maximum weeks. Therefore it is very seldom a PD Diagnostic is carried out exactly within this short time period. Another reason for PD activity in the XLPE cable section could originate to severe damages of the outer protective sheath.



Figure 90 PD graph of XLPE cable with PD activity concentrated at 3 joints

New XLPE cable arrangements:

- No PD acceptable during commissioning;
- < 100pC PD level up to 1,7U₀ must be below < 100pC
- In consideration of all terminations, joints as well as the entire cable

Aged XLPE termination/ joints

PDIV > U₀:

- 500pC location to be kept in records, no urgent need for action required
Repeating measurement after 2 years is recommended
- 2000pC location to be considered for medium term replacement.
Repeating measurement after 1 year is recommended

PDIV < U₀:

- 500pC location to be rechecked after 6 month
- 2000pC high potential to failure; to be scheduled for replacement
- 4000pC very high operating risk, to be replaced immediately

Note: Different values to be considered for

- Heat shrink joints / terminations
- Cold shrink joints / terminations
- Transition joints (XLPE- PILC in mixed cables)
- Different joint manufacturers

8.7.2 PD measurements at PILC and mixed cable circuits

PD detected in joints and terminations shows high concentration at a specific location. Double or even triple joints within several meters will lead to a less concentrated PD pattern.

For PILC it is very common to have non concentrated PD all over the length (scattered PD activities). Certain levels are not harmful and even a normal effect due to the cable design. If PD occurs more concentrated over a certain cable length it could indicate cable damage such as corrosion of the lead sheath, dried out sections etc. Dried cable section where oil has drained out will show higher PD levels and can be identified accordingly. Cables installed on hill-side areas often show a draining characteristic in accordance to the slope of the hill.

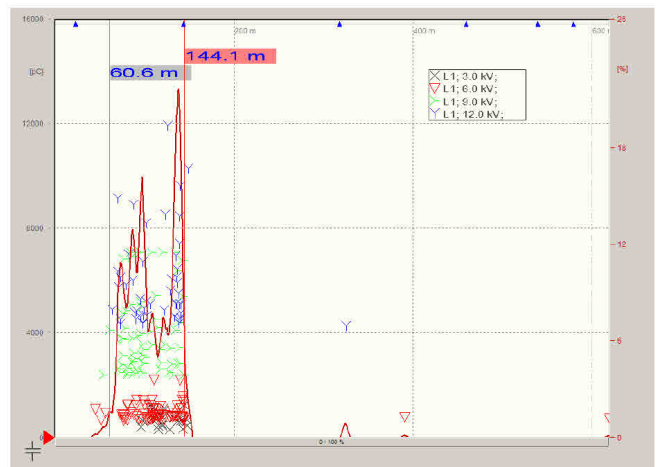

Figure 91 PD graph of mixed cable with scattered PD activity in PILC section

PD activities **along the cable** (dried out sections): ~ 9000pC

PD activities **in accessories** (terminations / joints):

PDIV > U₀:

20.000pC	location to be kept in records, no urgent need for action required Repeating measurement after 2 years is recommended
50.000pC	location to be considered for medium term replacement. Repeating measurement after 1 year is recommended

PDIV < U₀:

10.000pC	location to be rechecked after 6 month
20.000pC	high potential to failure; to be scheduled for replacement
40.000pC	very high operating risk, to be replaced on urgent basis

Note: Different values to be considered for

- Oil filled terminations
- Paper/oil joints
- Transition joints (XLPE-PILC in mixed cables)
- Different PILC cable types

9 Other Dielectric Diagnostic Methods – Their Theory and Suitability

Testing procedures are extremely important before putting cable systems into service, to ensure high reliability during permanent operation. Additionally, the users of cable systems are also interested in more detailed information about the aging stage of the insulation. Figure 92 shows an overall view of diagnostic techniques used and explained.

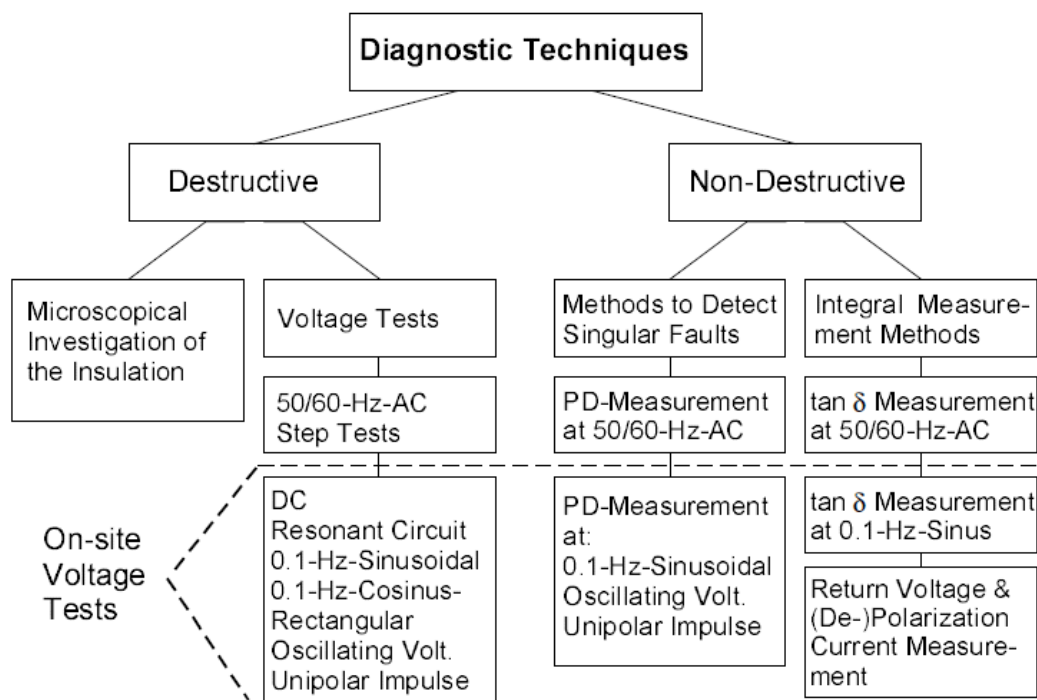

Figure 92 Survey of diagnostic techniques [24]

Polarization and conduction processes in an insulating material such as XLPE are a direct function of the structure of the material. These processes are also influenced by the aging, the water-tree deterioration, the moisture content and thickness of the insulation, etc. The dissipation factor measurement on XLPE-insulated medium voltage cables show that an evaluation of aging-state is possible.

Furthermore it may be the case that the return voltage measurement which is also based on polarization and conduction processes and which is used in testing oil-paper-insulated transformers can also characterize the aging state of polymer-insulated cables. [25]

Both methods shall be explained briefly. Detailed technical description can be found in dedicated papers.

In addition the application of a frequency swept method applied on cables is explained.

9.1 Cable Diagnostic System KDA 1 – IRC - Analysis

The Cable diagnostic instrument KDA 1 (Seba-Dynatronic) is based on the measurement of the depolarization current. The cable under test is charged at 1kV DC for 30 minutes. Then the cable is short-circuited for 5 seconds, and the depolarization currents are measured for the following 30 minutes (Figure 93). The measured data are saved and processed with Isothermal Relaxation Current (IRC) analysis. The depolarization current measured is described as the sum of three experimental functions where parameters a_j , τ_i are strongly correlated with the material properties. The time constant τ_3 is related to water tree degradation of the cable insulation.

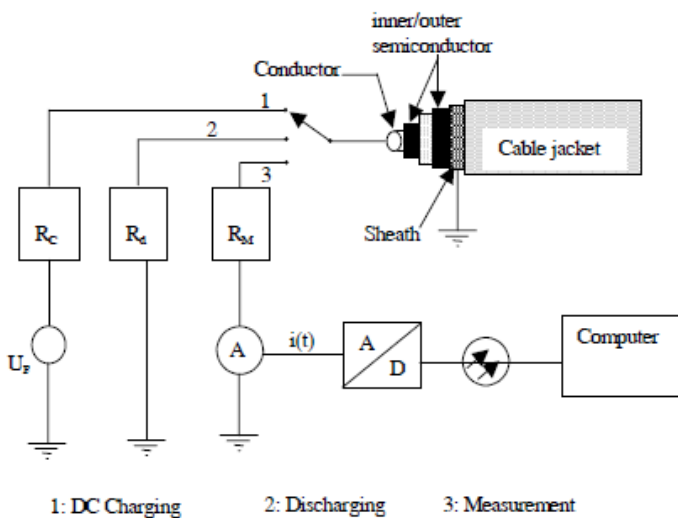

Figure 93 Basic measurement circuit for the IRC – Analysis, KDA1

An empirical ageing factor (A-factor) is calculated to classify the ageing condition of the cable. This factor is calculated from depolarization current based on time constants.

Suitability of KDA1 for underground cables:

- Studies found that the IRC result is not very conclusive in terms of details of the result.
- Time consuming diagnostic method



Bild 5: Prinzip ausgewählter zeitbereichsbasierter Diagnoseverfahren

Figure 94 (picture 5 [24]), prinzipial of selected time-range based diagnostic method

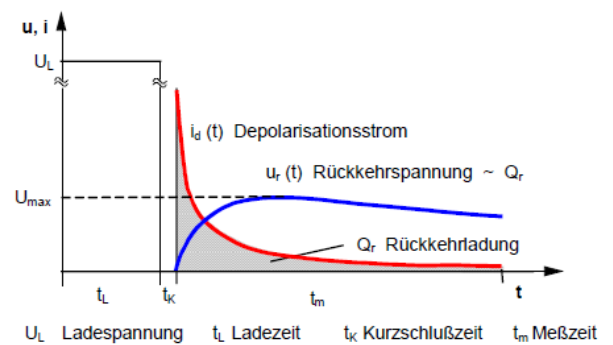

Bild 7: Depolarisationsströme normiert auf 100pF für unterschiedlich stark WT-geschädigte PE/VPE-Homopolymer-isolierte Kabel (sortiert nach elektr. Restfestigkeit U_d); Parameter: Ladedauer 15min, Kurzschlußdauer 1sec, Meßdauer 15min, Ladespannung $1U_0$)

Figure 95 (picture 7 of [24]), depolarization current of different water tree damaged PE/VPE cables

9.2 Cable Diagnostic System CD30/31- Return Voltage Method

The Cable Diagnostic System CD30 is for evaluation of the ageing degree and the damage condition of 1 kV to 30 kV PE and XLPE cables. The model CD31 is for oil-paper cables. The devices base upon measurement of **return voltages** at different charging voltages (Figure 96). The tested cable is charged with DC voltages (0.5, 1, 1.5, $2U_0$) for 5 minutes (switch S_1). Then, the high voltage source is turned off and the switch S_2 closed for two seconds to discharge the cable capacitance over a resistor R_D . (Hagenuk)

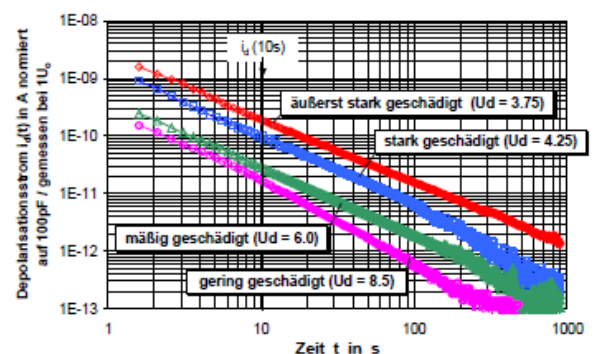
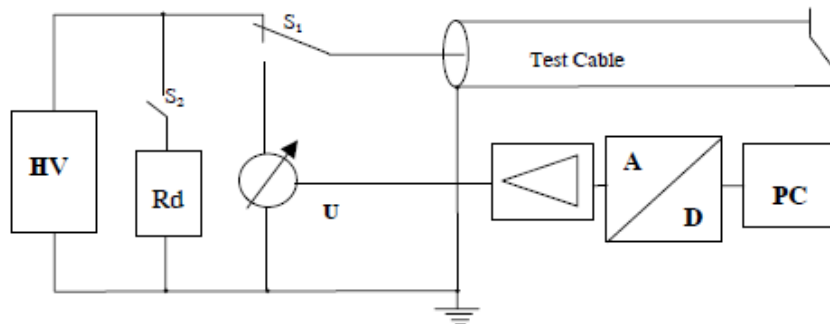

Figure 96 Block Diagram of the return voltage method [14]

After this time the return voltage is measured for 10 to 40 minutes, depending on the cable length. For that, the cable is connected to the high input impedance measurement receiver U (switch S_1). The measured value of return voltage is digitized and forwarded to the PC. The maximum values of the return voltages are plotted as a function of the charging voltage. This relationship can be linear or non-linear. The linearity factor is calculated as the ratio between the maximum values of the return voltage at $2U_0$ and U_0 and used as an indicator of the ageing condition. The factor greater than 2 is considered as a non-linear response and signifies ageing of the cable and the factor 3 indicates a strongly aged cable. [14]



Bild 6: Rückkehrspannungsspeak in Abhängigkeit der Ladespannung für unterschiedlich stark geschädigte PE/VPE-Kabel (Meßbeispiel, $t_L = 5$ min, $t_K = 2$ sec.)

Figure 98 picture 9 of [24], Return voltage peak for differently aged PE/VPE cables

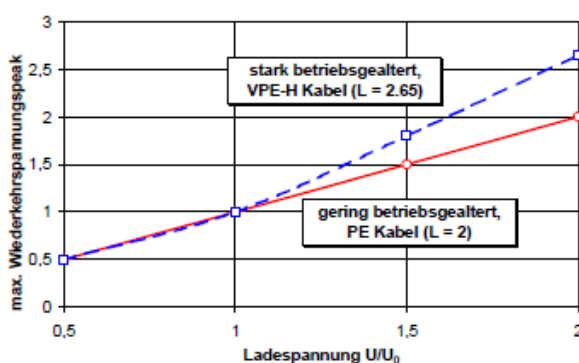

Bild 9: Vergleich zwischen der aus dem Depolarisationsstrom berechneten Rückkehrspannung und der praktisch erzielbaren Rückkehrspannung

Figure 97 picture 6 from [24], Comparison between the Return voltage calculated from Depolarization current and the practically measured return voltage

9.3 Insulation Diagnostic System IDA 200 – Sine Correlation Technique

Insulation Diagnostic System IDA 200 is a system that measures the complex impedance of a cable at a **variable voltage and frequency** (capacitance and $\tan \delta$ at 0.0001-1000 Hz). A digital signal processing unit (DSP) generates a test signal with the desired frequency (Figure 99).

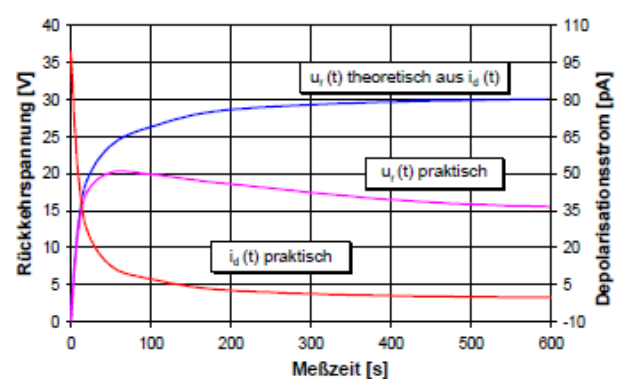
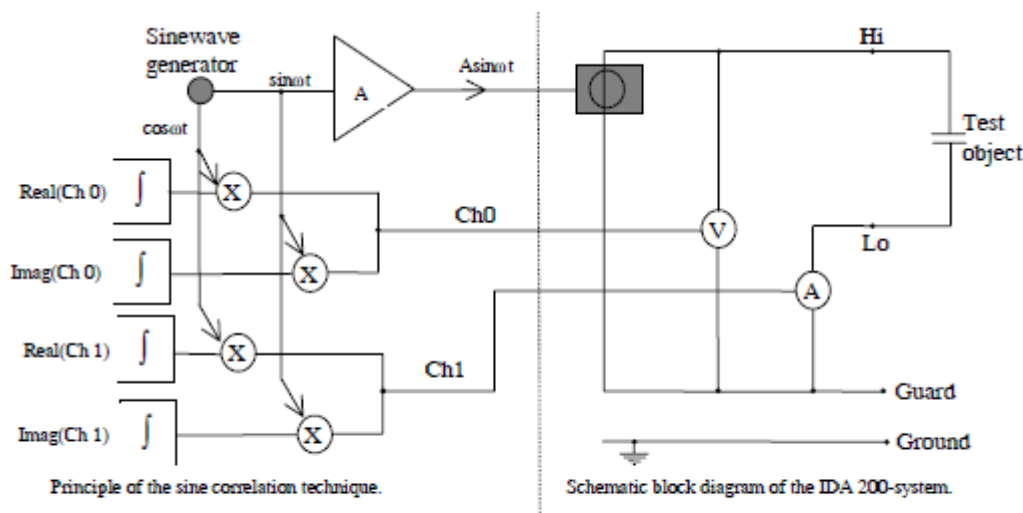

Fig. 10. Schematic block diagram of the IDA 200-system and the principle of the sine correlation technique.

Figure 99 Fig. 10 of [22] Schematic block diagram IDA 200 - system

The signal is amplified with an internal amplifier and then applied to the cable. The voltage over and the current through the specimen are measured with high accuracy using a voltage divider and an electrometer.

For the measuring input, IDA 200 uses a DSP unit that multiplies the input (measurement) signal with a reference sine voltage, and then integrates the results over a number of cycles. With this method, noise and interference is rejected-allowing IDA 200 to work with voltage levels up to 200 V and still achieve high accuracy and detail of analysis. (Programa) [14]

Suitability of IDA 200 for underground cable networks

- Frequency domain spectroscopy in XLPE cables cannot identify Water Tree aging
- Designed for analysis of aging condition of Paper Oil Insulations
- Determination of dielectric losses over the voltage request for high voltage source
- Not designed for dielectric response analysis of XLPE cables
- Aging condition of XLPE and mixed cables request 0.1Hz VLF source

9.4 Cable Testing and Diagnostic System PHG TD

The instrument PHG TD measures $\tan \delta$ at different sine voltage levels maintained at 0.1 Hz. The $\tan \delta$ at $2U_0$ and the difference between $2U_0$ and U_0 values are used as diagnostic criteria. A $\tan \delta$ value larger than $1.2 \cdot 10^{-3}$ at $2U_0$ or the difference of $\tan \delta$ at $2U_0$ and U_0 larger than $0.6 \cdot 10^{-3}$ signifies water tree deterioration. (Baur)

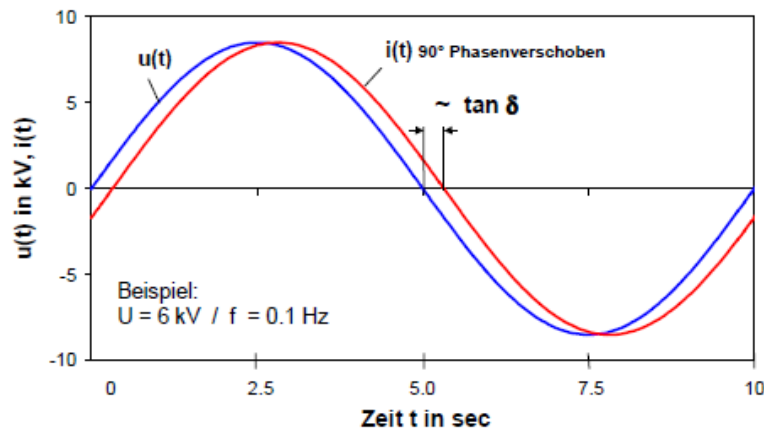

Figure 100, Tan Delta measurement [14]

10 Report example

10.1 Field examples for basic understanding

10.1.1 Example 1: Requirement of sensitivity of TD measuring system

New XLPE cables show very low TanDelta values. The value of such a cable can be below 0.2 E-3. To enable to compare TanDelta results of few year old cables with new cables it is necessary to use equipment with a measuring range of 1 E-4. Furthermore the accuracy must be below 1 E-5. The TD report shown in Figure 101 is indicating a rather new cable. L2 and L3 are free of partial discharge and show TD condition similar to a new cable. The sensitive measurement shows that L1 shows equal condition up to 19.7kV (1,5U₀). The 2U₀ value is increasing compared to the other phases. The enclosed PD measurement (Figure 102), shows that the far end termination of L1 indicates PD activity with an inception voltage of 1,7U₀.

Summary:

Basically, if the TanDelta result shows voltage independent flat graphs it is likely that no PD activity is present in the cable.

The TD graph (Figure 101) shows, that especially L1 has to be analysed for PD sources by means of a PD measurement.

If any instrument with incapable measuring range would be applied, the difference of L1 most probably would not be recognized and the cable is

judged as being in excellent condition.

The PD mapping result shows PD activity at the far end termination in L1. 450pC at 1,7U₀. The termination was investigated and put on schedule for replacement.

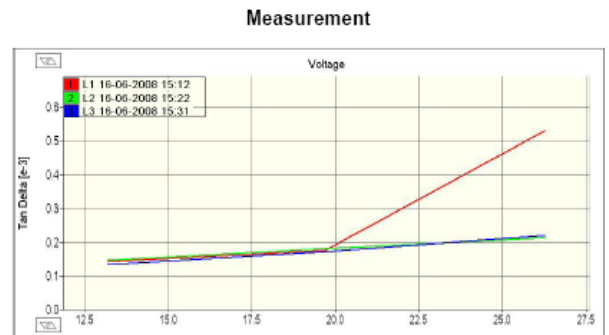

Cable can be returned to service

Evaluation	
Evaluation Name	XLPE
Expression	Comment
TD(2xU ₀)-(U ₀)>1.0	Cable with high operating risk
TD(2xU ₀)>2.2	Cable with high operating risk
TD(2xU ₀)<1.2	Cable can be returned to service
TD(2xU ₀)-(U ₀)<0.5	Cable can be returned to service
TD(2xU ₀)>1.2	Highly service aged cable

#	Time	Voltage kV	Current mA	Tan Delta E-3
1	15:26:14	19.7	1.8	0.18
2	15:26:24	19.7	1.8	0.18
3	15:26:34	19.7	1.8	0.18
4	15:26:44	19.7	1.8	0.18
5	15:26:55	19.7	1.8	0.18
6	15:27:04	19.7	1.8	0.18
7	15:27:15	19.7	1.8	0.18
8	15:27:25	19.7	1.8	0.18

Phase : L2
 Date/Time : 16-06-2008 15:27:26
 Step : 2
 Avg. Value Tan Delta : 0.182 E-3
 Standard Deviation : 0.001 E-3
 No. of Tests : 8
 Load : 147.4 nF
 Test sample VSE current : 110.5 uA
 Generator VSE current : 10.0 uA

Phase	Step	Voltage kV	Avg. Value Tan Delta	Std. Dev. [e-3]	Amount
L1	1	13.2	0.145	0.002	8
L1	2	19.7	0.177	0.001	8
L1	3	26.3	0.531	0.012	8
L2	1	13.2	0.148	0.002	8
L2	2	19.7	0.182	0.001	8
L2	3	26.3	0.215	0.010	8
L3	1	13.2	0.136	0.001	8
L3	2	19.7	0.173	0.002	8
L3	3	26.3	0.221	0.011	8

Figure 101 example of TD values of a new XLPE cable, low Std.dev., deviating L1 only visible with sensitive measuring range

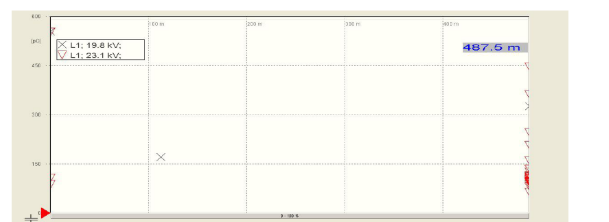

Figure 102, PD activity in L1, inception voltage 19kV, 450pC at 1,7U₀, far end termination

10.1.2 Example 2: TD measurement influenced by water ingress into joints

- 22.9kV XLPE Submarine cable
- Year of installation: 1985
- approx. length: 4.400m

In this example the 1st TanDelta diagnostic carried out in January 2008. The TD values of all 3 phases show up negative DTD values (Figure 104). The standard deviation is high with a value of 0.110 E-3. The negative DTD value indicates that the leakage current of the cable including all accessories is changing during the period of TD measurement.

The reason for such behaviour is most likely to be a joint with water ingress. During the TD measurement, the water may vaporize and let the joint dry out to a certain extent. As a side effect the high standard deviation (representing instable leakage condition) is a clear indication for water in a joint. This first result therefore is not yet representing the TD value of the cable. In such a case, the TD measurement in each phase should be repeated without interruption. The repeating result would most likely start much lower compared to the U_0 - value of the first measurement.

The cable was kept in operation without any action after the first measurement in January 2008. The repeating measurement after one year shows much lower TD values. The slight

negative tendency from U_0 to $1,5U_0$ is most likely caused by a little remaining humidity in a joint. The further values from $1,5U_0$ to $2U_0$ show the real TD value of the cable.

Why does the first measurement start much higher compared to the second? What is the difference whether the cable is live or whether VLF voltage

is applied during diagnostic? These questions are not related to the applied voltage. Either the 50Hz line voltage or the VLF voltages applied during TD measurement are both causing the water to vaporize. The important point in this case is found in the duration between

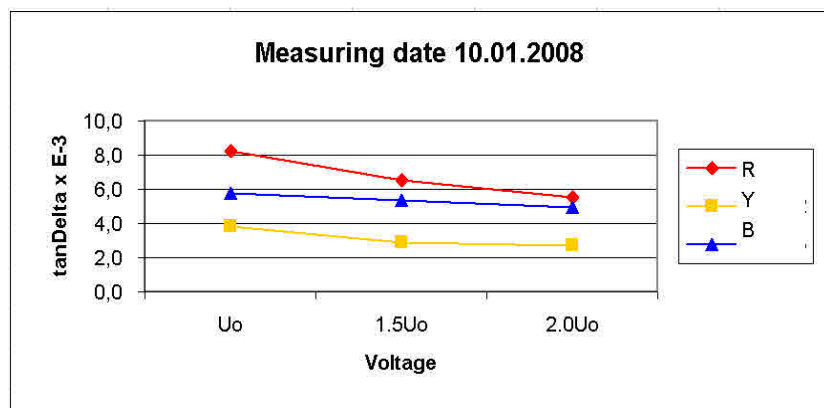

Figure 104 TD result 10.01.2008, high operating risk, decreasing DTD, influence of water ingress in joint.

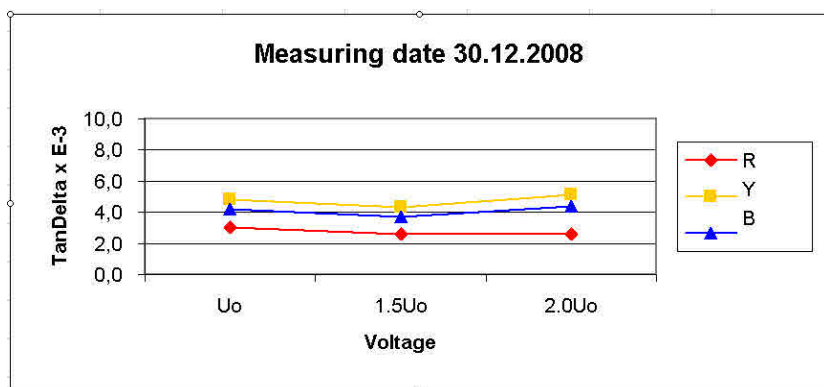

Figure 103 TD result 30.12.2008, high operating risk, no water influence

switching the cable out of service off and carrying out the TD measurement. The first time, the cable was switched off several hours enabling water to penetrate the joint whereas the second time on 30.12.2008 the test was carried out immediately after shut down.

Summary:

In this practical example, the first measurement was not representing the cable's loss factor value. It was highly influenced by water ingress in a joint. The PD measurement did not show any activity as well. Water is preventing PD activity to ignite. The second measurement is representing the cable and the cable was finally judged as cable with high operating risk. As it is a submarine cable that is already more than 20 years in operation, the effect of water tree along the cable is considered. The TD value at 2Uo exceeded 2.2E-3 and was scheduled for replacement.

10.2 Report Example for Combined TD / PD Diagnostic

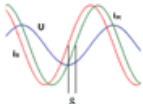

BAUR VLF Testing and Diagnosis Report
Combined TanDelta & Partial Discharge Diagnosis

Report No. H1011025

HEC Ref:	EHT 423
Date of Test:	27/10/2011
Weather:	Fine
Humidity:	60%
Requested by:	Power Utility
Cable Location:	from Point: Zone Terrace Z/S, Sw. #31 to Point: Hiller St 7, Sw. #1
Cable Type:	XLPE
Pick ID	
Near end (From):	Zone Terrace Z/S, Sw. #31
Far end (To):	Hiller St 7 Sw1, Sw. #1
Pulse Velocity (m/ μ s)	88.0
Cable Length:	1183m
Nominal Voltage:	11kV
Manufacturer:	
Year Of Manufacture:	
Number Of Phases:	3
Soil Condition	n/a
Joint positions	18 joints
Test site:	Zone Terrace Z/S, Sw. #31

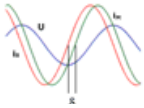

BAUR VLF Testing and Diagnosis Report
Combined TanDelta & Partial Discharge Diagnosis

Rated Voltage	Material Code	Size	Length(m)
11	AX	300sqmm	651
11	CX	300sqmm	465
11	CXS	300sqmm	67

Jnt	MAKE	DATE	WEATHER	LUG	ENGINEER	JOINTER	SWITCH	REMARKS	MAP	CO-ORDINATE	SKETCH NO
X	RAYR	08-JUN-1995	FINE			5542		1	11SW15B2	837263.657,815545.966	0600/1995
1	RAYR	08-JUN-1995	FINE			5542	J 713		11SW15B2	837270.382,815521.578	0600/1995
							J1393				
2	RAYR	08-JUN-1995	FINE			5542	J 713		11SW15B2	837297.962,815550.756	0600/1995
							J1297				
							J1393				
3	RAYR	24-MAR-1993	UNKNOWN			4392	J 839		11SW15B2	837337.785,815556.677	290/1994
4	RAYW	01-SEP-2006	CLOUDY			4388	S5079		11SW15B2	837360.844,815579.569	2270/2006
							S5006				
5	RAYW	01-SEP-2006	CLOUDY			4388	S4995		11SW15B2	837363.599,815582.470	2270/2006
							S6158				
6	RAYW	03-SEP-2000	CLOUDY			4238	J5001		11SW15B2	837405.580,815559.358	2265/2000
							J5686				
7	RAYW	20-AUG-2003	FINE			4243	S5637		11SW15B2	837408.714,815556.776	1928/2003
8	RAYW	14-AUG-2003	RAIN			5963	W1299		11SW15B2	837441.388,815546.672	2147/2003
9	RAYW	20-AUG-2003	FINE			4243	S6297		11SW15B2	837497.537,815533.381	1928/2003
10	RAYR	09-DEC-1994	UNKNOWN			4228	J1250		11SE11A1	837527.192,815537.379	0516/1995
							J 934				
11	RAYW	21-JUL-2005	RAIN			2994	S5686		11SE11A1	837610.954,815517.753	2168/2005
							S5191				
12	RAYW	21-JUL-2005	RAIN			2994	S5004		11SE11A1	837614.570,815516.965	2168/2005
							S5014				
13	RAYR	09-DEC-1994	UNKNOWN			4228	J1250		11SE11A1	837628.291,815510.023	0516/1995
							J 934				
14	RAYW	21-JAN-2002	FINE			5542	S6297		11SE11A1	837778.936,815424.549	0716/2002
15	RAYW	18-JUL-2000	RAIN			5542	S5446		11SE11A1	837739.534,815468.068	2210/2000
							S5047				

Jnt	MAKE	DATE	WEATHER	LUG	ENGINEER	JOINTER	SWITCH	REMARKS	MAP	CO-ORDINATE	SKETCH NO
16	RAYW	26-MAR-2003	FINE		5850	W1297			11SE11A1	837714.288,815530.492	0712/2003
17	RAYW	25-FEB-2003	FINE		5850	W 407			11SE11A1	837735.084,815545.155	0712/2003
18	RAYW	07-JAN-2003	FINE		5850	W 407			11SE11A1	837727.767,815559.969	0712/2003
Y	RAYR	26-FEB-2003	FINE		5850	W1239	31		11SE11A1	837700.071,815569.544	0712/2003

X	0	1	2	3	4	5	6	7	8								
R-	48	-	70	-	58	-	37	[1-3]	4	[3-2]	80	[3-	3	[1-3]	67	[3-	
Y-								[2-1]		[1-1]				[2-2]			[2-
B-	300 SQMM AX	-	300 SQMM AX	-	300 SQMM AX	-	300 SQMM AX	[3-2]	300 SQMM CX	[2-3]	300 SQMM AX	[2-	300 SQMM CX	[3-1]	300 SQMM CXS	[1-	
	JUN-1995		OCT-1993		MAR-1993		MAR-1993		01-SEP-2006		MAR-1993		03-SEP-2000		10-JUL-2003		
	BICC 0		BICC 0		BICC 0		BICC 0		PIRE2004		BICC 0		BICC2000		PIRE2003		
8		9	10	11	12	13	14	15	16								
Z	Z A		Z A	Z Z	Z Z		Z A	A A	Z								
3	66	[3-2]	47	-	97	[2-1]	4	[1-2]	22	-	192	[1-1]	113	[1-2]	115	[2-	
2		[2-1]				[1-3]		[3-3]						[2-2]			
1	300 SQMM CX	[1-3]	300 SQMM AX	-	300 SQMM AX	[3-2]	300 SQMM CX	[2-1]	300 SQMM AX	-	300 SQMM AX	[3-3]	300 SQMM CX	[3-3]	300 SQMM CX	[1-	
	01-AUG-2003		DEC-1994		DEC-1994		21-JUL-2005		DEC-1994		DEC-1994		16-JUN-2000		28-APR-2000		
	PIRE2003		BICC 0		BICC 0		PIRE2004		BICC 0		BICC 0		BICC1999		BICC1999		
16	17	18	Y														
A	Z A	Z Z	A														
1	35	[1-1]	39	[1-2]	86	[2-R											
2		[2-2]		[2-1]		[1-Y											
3	300 SQMM CX	[3-3]	300 SQMM CX	[3-3]	300 SQMM CX	[3-B											
	18-FEB-2003		20-DEC-2002		01-AUG-2002												
	PIRE2002		PIRE2002		TAIH2002												

Note: FW - Free Water Ingress; WT - Water Tree.
 *RPT-I-NORMAL, normal completion - end of report

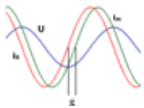

BAUR VLF Testing and Diagnosis Report
Combined TanDelta & Partial Discharge Diagnosis

TD & PD Measurement on 27 OCT 2011

TD Result recorded on 27 OCT 2011:

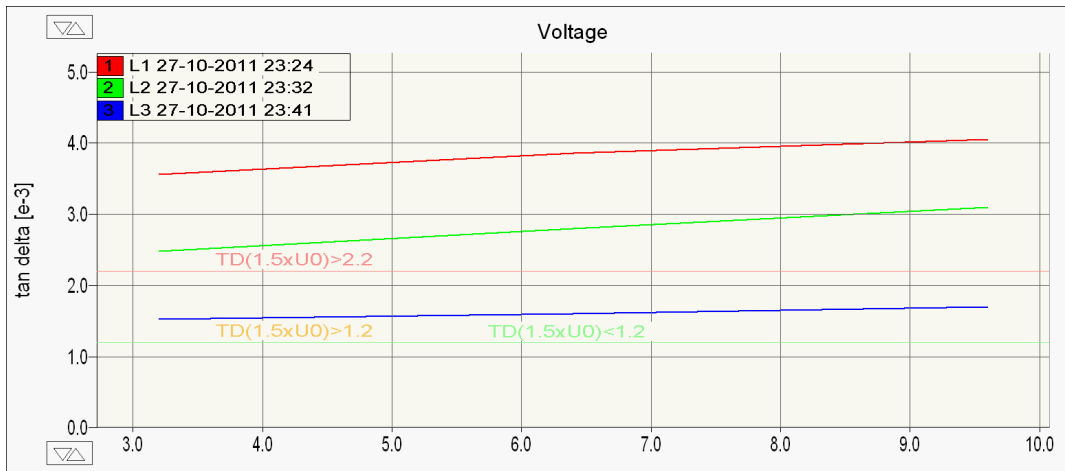

TD analysis was obtained on 27 OCT 2011:

The results of L1, L2 & L3 were obtained. Base on the 1.5U₀ XLPE cable evaluation, the results show that L2 & L3 has reached above the limit (high operating risk) and L1 has reached the highly service aged condition. Same characteristics can be observed for all cables. The average TD values increase as the voltage steps up. The TD standard deviation of L1, L2 & L3 are in rather good condition (<0.01E-3). The slightly fluctuated stability trend could show presence of small humidity in L1, L2 & L3 (terminations). The delta TD values in L1, L2 & L3 are indicating good cable condition (<0.6x E⁻³). Potential water tree indication (increasing delta TD) could have become visible due to the cable length.

Table of Average tan delta value (E-3):

Voltage:	3.2kV	6.5kV	9.7kV
L1	3.560	3.859	4.046
L2	2.476	2.803	3.094
L3	1.526	1.605	1.700

Table of Standard Deviation:

Voltage:	3.2kV	6.5kV	9.7kV
L1	0.005	0.004	0.006
L2	0.023	0.024	0.024
L3	0.003	0.003	0.004

TD Stability Trend:

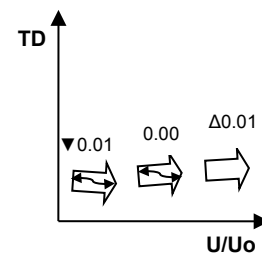
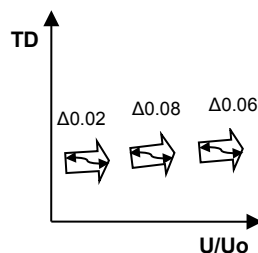
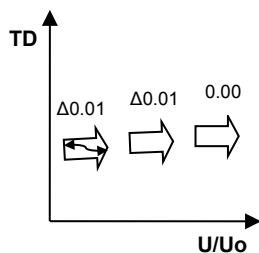

Summary:

Phase	Step	Voltage kV	Avg. value tan delta	Std. Dev. [e-3]	Load nF
L1	1	3.2	3.560	0.005	8
L1	2	6.4	3.859	0.004	8
L1	3	9.6	4.046	0.006	8
L2	1	3.2	2.476	0.023	8
L2	2	6.4	2.803	0.024	8
L2	3	9.6	3.094	0.024	8
L3	1	3.2	1.526	0.003	8
L3	2	6.4	1.605	0.003	8
L3	3	9.6	1.700	0.004	8

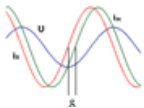

BAUR VLF Testing and Diagnosis Report
Combined TanDelta & Partial Discharge Diagnosis

on 27 OCT 2011:

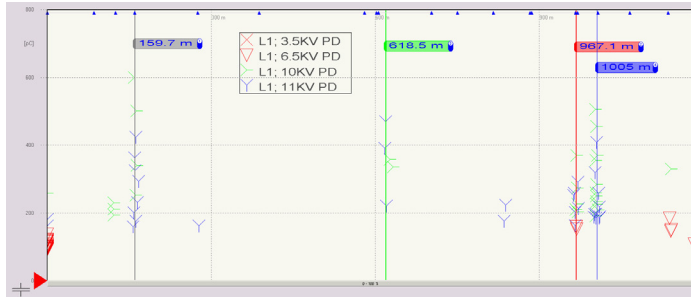

Descriptions

- 1 L1; truesinus®; 0.1 Hz; 28.10.2011 00:14:21; 3.5KV PD
- 2 L1; truesinus®; 0.1 Hz; 28.10.2011 00:18:04; 6.5KV PD
- 3 L1; truesinus®; 0.1 Hz; 28.10.2011 00:22:15; 10KV PD
- 4 L1; truesinus®; 0.1 Hz; 28.10.2011 00:23:54; 11KV PD

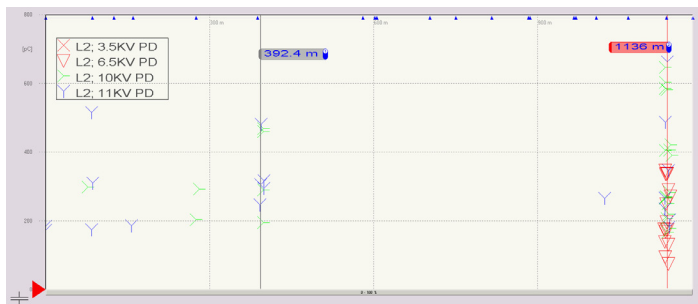

Descriptions

- 1 L2; truesinus®; 0.1 Hz; 28.10.2011 00:40:40; 3.5KV PD
- 2 L2; truesinus®; 0.1 Hz; 28.10.2011 00:43:16; 6.5KV PD
- 3 L2; truesinus®; 0.1 Hz; 28.10.2011 00:45:22; 10KV PD
- 4 L2; truesinus®; 0.1 Hz; 28.10.2011 00:46:35; 11KV PD

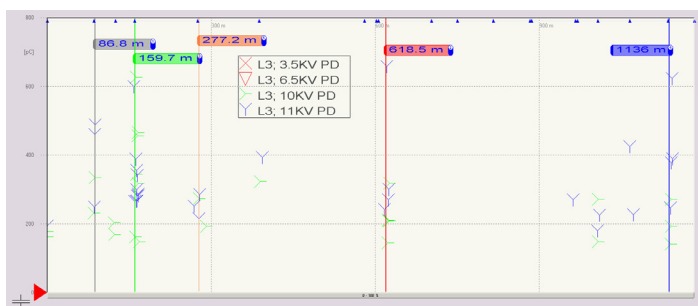

Descriptions

- 1 L3; truesinus®; 0.1 Hz; 28.10.2011 00:49:28; 3.5KV PD
- 2 L3; truesinus®; 0.1 Hz; 28.10.2011 00:53:08; 6.5KV PD
- 3 L3; truesinus®; 0.1 Hz; 28.10.2011 00:54:24; 10KV PD
- 4 L3; truesinus®; 0.1 Hz; 28.10.2011 00:55:13; 11KV PD

PD Result recorded

PD activity in L1:

- Concentrated PD (up to ~150pC) at the near end, with PDIV starting at 1.0U_o.
- Concentrated PD (up to ~300pC) at the location of **160m** joint away from the near end with PDIV starting at 1.5U_o.
- Concentrated PD (up to ~400pC) at the location of **619m** joint away from the near end with PDIV starting at 1.5U_o.
- Concentrated PD (up to ~300pC) at the location of **967m** joint away from the near end with PDIV starting at 1.0U_o. (Close joints)
- Concentrated PD (up to ~300pC) at the location of **1005m** joint away from the near end with PDIV starting at 1.5U_o.

PD activity in L2:

- Concentrated PD (up to ~300pC) at the location of **392m** joint away from the near end with PDIV starting at 1.5U_o.
- Concentrated PD (up to ~400pC) at the location of **1136m** joint away from the near end with PDIV starting at 1.0U_o.

PD activity in L3:

- Concentrated PD (up to ~300pC) at the location of **87m** joint away from the near end with PDIV starting at 1.5U_o.
- Concentrated PD (up to ~400pC) at the location of **160m** joint away from the near end with PDIV starting at 1.5U_o.
- Concentrated PD (up to ~300pC) at the location of **277m** joint away from the near end with PDIV starting at 1.5U_o.
- Concentrated PD (up to ~300pC) at the location of **619m** joint away from the near end with PDIV starting at 1.5U_o.
- Concentrated PD (up to ~300pC) at the location of **1136m** joint away from the near end with PDIV starting at 1.5U_o.

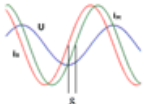

BAUR VLF Testing and Diagnosis Report
Combined TanDelta & Partial Discharge Diagnosis

PD activity in daily operation,
1.0Uo:

- Concentrated PD (up to ~120pC) at, the near end, Moreton Terrace Z/S, in L1.
- Concentrated PD (up to ~240pC) at the location of **1136m** joint away from the near end in L1 & L2.

Descriptions

- 1 L1; truesinus®; 0.1 Hz; 28.10.2011 00:18:04; 6.5KV PD
- 2 L2; truesinus®; 0.1 Hz; 28.10.2011 00:43:16; 6.5KV PD
- 3 L3; truesinus®; 0.1 Hz; 28.10.2011 00:53:08; 6.5KV PD

PD Summary for L1, L2 & L3:

In summary, concentrated PD at **160m & 1005m** joint away from the near end with the PDIV at **1.5Uo (10kV)**, approx. up to **300pC** in **L1**. Concentrated PD also occurs at **619m** joint away from the near end with the PDIV at **1.5Uo (10kV)**, approx. up to **400pC** in **L1**. Concentrated PD also occurs at **967m** joint (close joints) away from the near end with the PDIV at **1.0Uo (6.5kV)**, approx. up to **300pC** in **L1**.

Concentrated PD occurs at the location of **392m** joint away from the near end with the PDIV at **1.5Uo (10kV)**, approx. up to **300pC** in **L2**. Concentrated PD also occurs at **1136m** joint away from the near end with the PDIV at **1.0Uo (6.5kV)**, approx. up to **400pC** in **L2**.

Concentrated PD occurs at the location of **87m, 277m, 619m & 1136m** joint away from the near end with the PDIV at **1.5Uo (10kV)**, approx. up to **300pC** in **L3**. Concentrated PD also occurs at **160m** joint away from the near end with the PDIV at **1.5Uo (10kV)**, approx. up to **400pC** in **L3**.

Concentrated PD (up to ~150pC) at the near end is also noted when recording **L1 with the PDIV at 1.0Uo**.

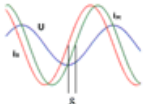

BAUR VLF Testing and Diagnosis Report
Combined TanDelta & Partial Discharge Diagnosis

Required action and conclusion

PD Evaluation:

In conclusion, PD level of $\sim 120\text{pC}@1.0U_0$ at the near end in L1 has no affect during normal operation for XLPE cable. A normal joint with PD level of $\sim 240\text{pC}@1.0U_0$ at 1136m away from the near end in L1 & L2 also has no affect during normal operation. PD activity in general is not affecting the TD results.

TD Evaluation:

TD results show that L2 & L3 are in high operating risk according to the $1.5U_0$ XLPE cable evaluation whereas L1 is in highly service aged condition. The TD standard deviation of L1, L2 & L3 are in rather good condition. The slightly fluctuated stability trend could show presence of small humidity in L1, L2 & L3 (terminations).

According to the generally high aging condition, it is recommended to retest all three phases after several months or perform a VLF test to recognize certain highly aged locations.

13.01.2012
TN/GIC

11 Latest projects of BAUR Diagnostic Services

11.1 Hong Kong Electric

Hong Kong Electric has started to implement the idea of Modern Asset Management in 2008. The basic motivation of HK Electric resulted on the common dilemma to ensure power supply reliability in the city of Hong Kong that consists of several thousands of 11kV underground cables.

The cable network consists of old PILC cables have been installed since 1950, water tree prone first generation XLPE as well as water tree retardant XLPE cables since 1986.

<p><i>22kV / 11kV Distribution Network</i></p>	<p>HK Electric's 22kV / 11kV network comprises cables buried directly underground. The total length of cables is over 3,000km. The Company has adopted the use of XLPE insulation for all its cables since 1980. As a standard, all cables use 300mm² copper conductor with corrugated aluminium metal sheath/steel wire armour and PVC/MDPE outer-jacket.</p>	<p>Electricity supply network at 22kV / 11kV level is in the form of a close or an open ring. Any 22kV / 11kV substation is normally fed from one source zone substation. Alternative route is always available from another source substation in case of fault or cable taken out of service.</p>
--	---	--

The total length of underground cables in the distribution network is over
配電網絡內地底電纜的總長度超過
3,000km公里



Figure 105 HK Electric company profile 10/2010 [26]

Practical diagnostic experience has started to be collected in Hong Kong in 2010. The deciding step was made when HK Electric Asset Management understood to take action on the maintenance of the medium voltage cable network in order to improve the reliability of the power supply to the city of Hong Kong, the financial center of Asia.

With the implementation of a new technology for diagnostic of underground cable networks it became possible to develop a strategy and philosophy for preventive maintenance in the medium voltage network. Difficulties arose with the interpretation of diagnostic results being the core issue when performing condition based maintenance.

HK Electric has purchased numerous portable and test van based VLF TD /PD test instruments. After conducting the operators' training, a diagnostic team has been setup. Engineers performed cable diagnostic for condition assessment on extremely high frequency. Since 2010 more than 1,500 cables have been diagnosed.

The key challenge for the asset management team was faced, when the diagnostic results had to be analyzed and measures had to be defined. The team of BAUR supported the asset management team with numerous training sessions and field investigation. Action plans have been worked out on numerous cases and action was taken. The success rate of correctly identified weak cable sections and joints in XLPE as well as PILC components was impressively underlined by dissection and visual inspection of replaced components.

As a result of intensive cooperation, BAUR supported HK Electric to establish a Cable Testing Philosophy that defines the required action plan for maintenance work in respect to the individual cable condition.

THE HONGKONG ELECTRIC CO.,LTD. 香港電燈有限公司 T&D DIVISION		Effective Date: 14 April 2012
Departmental Technical Manual	11kV & 22kV Distribution Plant	
Part 0	Work Instruction	
T&D/WI/HV/52	HIGH VOLTAGE TESTING FOR 11KV AND 22KV CABLE	
<p>Note: Major parts of this instruction is revised based on the experience gained on VLF diagnostic testing of 11kV cables since its introduction in early 2010.</p>		
		Action
1.	<p><u>TESTING PHILOSOPHY</u></p> <p>11kV cable system comprises of PILC cables (as early as 1950's), XLPE cables with water tree prone cable sections (WTPCS) and water tree retardant XLPE cables introduced since 1986.</p>	

Figure 106; HK Electric Testing Philosophy 2012

The confidence towards the professional support by BAUR developed and led to consultancy service contracts.

- Contract 1: 2010 50 cables
- Contract 2: 2011 100 cables
- Contract 3: 2012 250 cables
- Contract 4: 2013 350 cables
- Contract 5: 2014-2015 350 cables / year

Beside the diagnostic service by BAUR, more than 1,000 cables have been diagnosed by HK Electric engineers.

The statistical evaluation of the categorization data revealed, that only 1.5% of the diagnosed cables were judged wrongly or unexpected / unidentified weaknesses led to cable failures. Therefore, a confidence level of 98.5% underlined the developed cable maintenance philosophy.

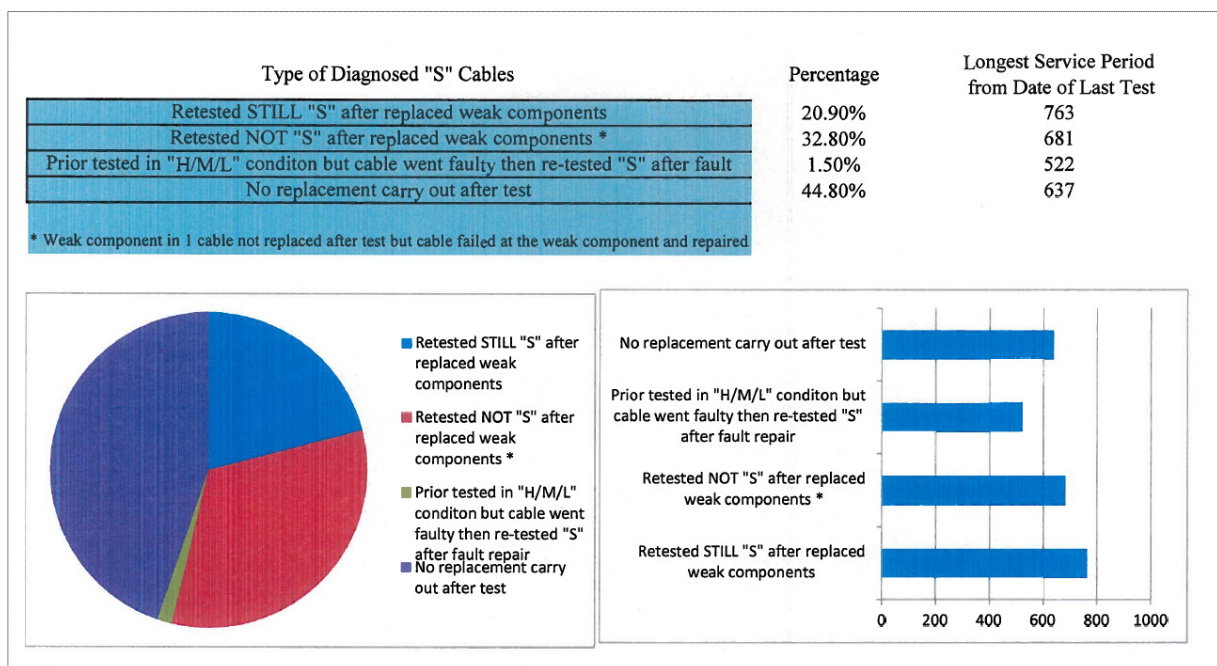

Figure 107 HKE statistical review of cable categorization



Figure 108: BAUR VLF TD / PD Systems used

11.2 KEPCO Korea

The Korean Electric Power Company (KEPCO) is handling the whole power generation, power transmission as well as power distribution of the Republic of South Korea. The cooperation of BAUR with KEPCO started in 2005 where the research institute of KEPCO called KEPRI started to evaluate the right tool for assessment of dielectric loss measurement and water tree detection. KEPRI is a well-known research institute. Close cooperation and support allowed linking KEPRI with research institutes worldwide. The continuous support and experience of BAUR developed the confidence towards the VLF diagnostic technology developed by BAUR. In 2010, KEPCO ordered 10 cable test vans for VLF testing and diagnostic. In 2012, another 5 test vans were delivered. With the purchase of the first batch of diagnostic equipment each KEPCO operational region setup a diagnostic team. In the headquarters of KEPCO, a diagnostic expert team was formed. All regions reported their diagnostic results to the experts in the headquarters. BAUR has been supporting the diagnostic team with numerous visits and user seminars. Till today, three papers of KEPCO have been published on international conferences illustrating the experience and professional assessment of the cable condition throughout South Korea. The latest paper mentions that 14,000 cables have been diagnosed and registered in the data base.

Based on this huge volume of diagnostic results, further studies on development of new diagnostic criteria are in progress. The cooperation with BAUR is expected to bring up another highlight of useful tools for condition based cable maintenance.



Figure 109: KEPCO Diagnostic Experience

ABSTRACT

Recently, diagnostic on Medium Voltage Cables using $\tan \delta$ measurement that measures dissipation factor with 0.1Hz VLF (Very Low Frequency) high voltage source has emerged as an efficient way to assess water tree aging of MV (Medium Voltage) cables. This study verified the validity diagnostic evaluation criteria defined by IEEE400.2-2013 and it's pervious drafts of DTD (Delta $\tan \delta$) and STDEV (Standard Deviation) - indicating voltage-stability and time-stability of $\tan \delta$ respectively - by applying $\tan \delta$ measurement to KEPCO (Korea Electric Power Corporation)'s power distribution system and suggested a new assessment factor being defined as Skirt, and its new formula in order to identify the precursor of insulation breakdown with patterns of $\tan \delta$. By visualizing complex correlations between various assessment factors and proposing a 3-dimensional assessment standard that can normalize the deterioration condition of a cable into a uniform value, this study has established a foundation to calculate the remaining life time of a cable through VLF $\tan \delta$ diagnostic.

Index Terms — VLF, $\tan \delta$, TD, DTD, STDEV, Skirt, 3-dimensional matrix

Figure 110: extract of resent paper by KEPCO 2013 [27] [28]

11.3 Western Power / Australia

BAUR's cooperation with Western Power has started in 2007 with the delivery of the first Cable Diagnostic equipment in Australia. At that time, diagnostic experience was not available and support was required. Numerous visits and case study investigations allowed combining the experience of European power utilities with local conditions in Australia. Western Power very soon gained confidence with their understanding of successful cable condition assessment and started to setup a new division now offers cable diagnostic services to other organizations and utilities in Australia. BAUR supported Western Power to continue the experience sharing on management basis and started cooperation with a German power utility and published a joined paper on the IEEE 2010 International Conference on Condition Monitoring and Diagnosis in Taiwan.

Figure 111: Benefits of a combined diagnostic method CMD 2010 [29]

11.4 Other cooperations

- BAUR Germany
 - As subsidiary of BAUR Austria, operating as service provider for cable condition assessment and consultancy for power utilities and private organizations in Germany since 2005. Diagnostic experience of approximately 100 cables per year.

- Gasenzer AG Switzerland
 - Gasenzer AG is operating as diagnostic service provider for power utilities, all nuclear power plants, airports and other private customers throughout Switzerland since 2004. Up to now, Gasenzer AG is the only trusted partner and service provider for condition assessment of underground cables throughout Switzerland

11.5 BAUR Diagnostic platform

During the past years, diagnostic experience has been collected throughout the world. The BAUR Diagnostic platform is a forum where experts are sharing the experience from all around the world which allows sharing new understandings and findings in order to benefit from the experience collected under all kind of possible field conditions. The experts of BAUR are considered to be most experienced when it comes to competency and flexibility to analyze underground cable networks.

12 Appendix – Case Studies combined diagnostics

12.1 Case Study A 1 - 11153

Key points:

- 322m, 22kV, XLPE cable, 1 joint
- PD activities at a joint
- Water ingress in a joint
- Damage found near the joint
- Replacement of joints show improvement in TD value

Our Ref:	A1 - 11153
Date of Test:	06.12.2011 / 31.01.2012
Weather:	Sunny
Humidity:	60%
Requested by:	Electricity Company Australia
Cable Location:	VIC, Lakeside
Cable Type:	XLPE 22kV
Pick ID	No 11153
Near end (From):	Lakeside 12
Far end (To):	Queens Road 3
Pulse Velocity (m/ μ s)	81.8
Cable Length:	322m
Nominal Voltage:	22kV
Year Of manufacture:	2002 (year of installation)
Number Of Phases:	3
Soil Condition	moist
Joint position	97m
Test site:	Lakeside 12
Used test equipment	BAUR Frida TD (for TD measurement) BAUR PD portable (for PD measurement)



12.1.1 Cable Layout

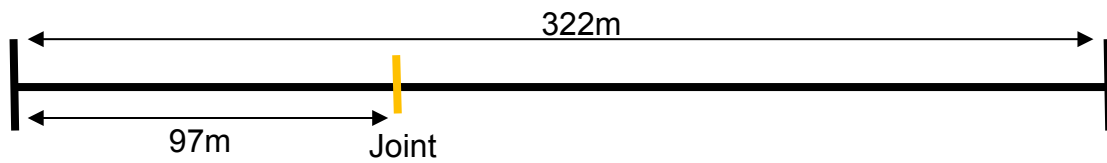

12.1.2 TD result 06.12.2011

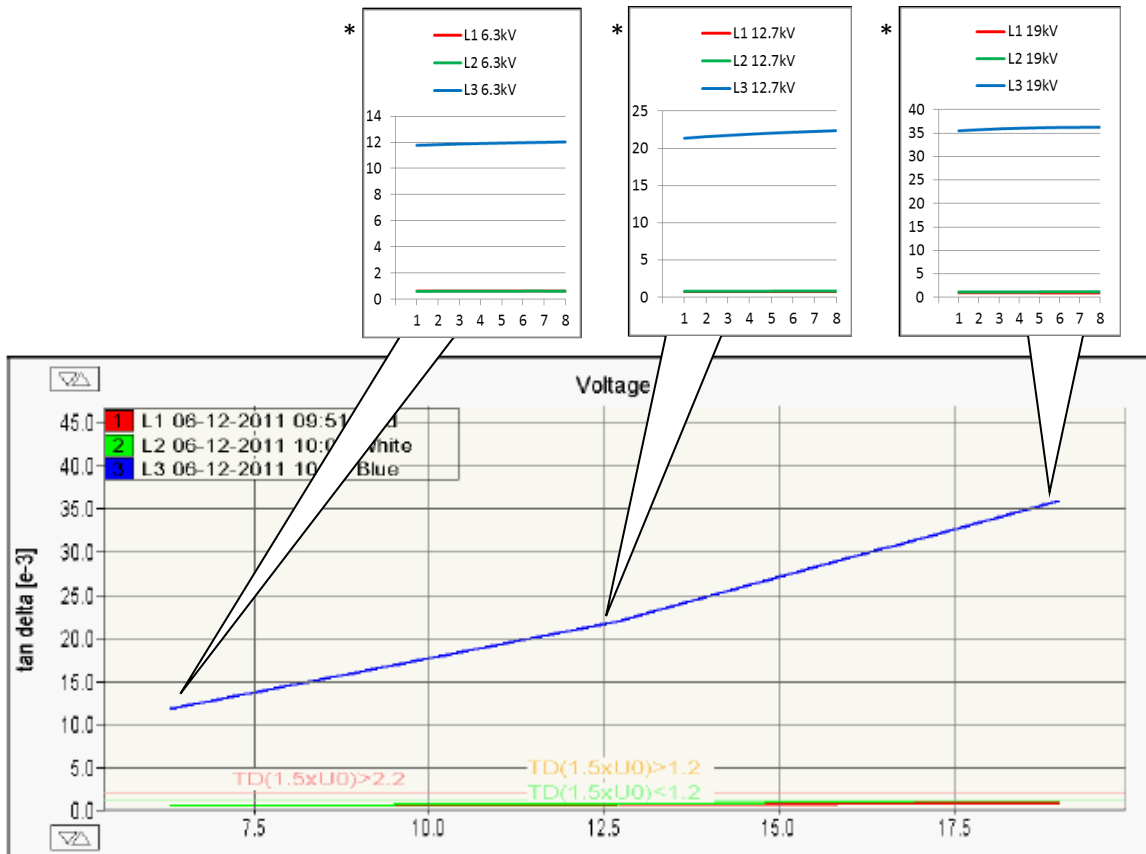

Cable with high operating risk

Evaluation

Name of Evaluation	XLPE 1,5U ₀
Criterion	Comment
TD(1.5xU0)>2.2	Cable with high operating risk
TD(1,5xU0)-(0.5U0)>1.0	Cable with high operating risk
TD(1.5xU0)>1.2	Highly service aged cable
TD(1.5xU0)<1.2	Cable can be returned to service
TD(1.5xU0)-(0.5U0)<0.6	Cable can be returned to service

Table of Average tan delta value:

Voltage:	6.3kV	12.7kV	19kV
L1	0.632	0.772	0.979
L2	0.621	0.837	1.177
L3	11.914	21.929	35.980

Table of Standard Deviation:

Voltage:	6.3kV	12.7kV	19kV
L1	0.002	0.002	0.006
L2	0.005	0.006	0.010
L3	0.085	0.328	0.251

Summary:

Phase	Step	Voltage kV	Avg. value tan delta	Std. Dev. [e-3]	Amount	Load nF
L1	1	6.3	0.632	0.002	8	80.6
L1	2	12.7	0.772	0.002	8	80.4
L1	3	19.0	0.979	0.006	8	80.8
L2	1	6.3	0.621	0.005	8	81.1
L2	2	12.7	0.837	0.006	8	80.8
L2	3	19.0	1.177	0.010	8	81.3
L3	1	6.3	11.914	0.085	8	80.4
L3	2	12.7	21.929	0.328	8	80.1
L3	3	19.0	35.980	0.251	8	80.6

TD result interpretation:

- Overall cable condition... high operating risk
- Absolute TD values
TD of L1, L2 very low ... good condition
TD of L3 very high ... high operating risk
- TD standard deviation
STD L1, L2 very low, stable condition ... dry condition
STD L3 very high, unstable condition ... indication of water ingress in one of the joints
- DTD (Delta TD)
DTD of L1, L2 no increase of TD over the voltage
DTD of L3 high value, strongly increasing TD value with higher voltage, indication of voltage related leakage condition, approx. 24.0×10^{-3}
- TD trend analysis*
L1 and L2 very stable trend condition
L3 increasing trend behaviour
(see *TD trend graphs)
- Investigation of L3 is required

12.1.3 PD Result recorded on 06.12.2011

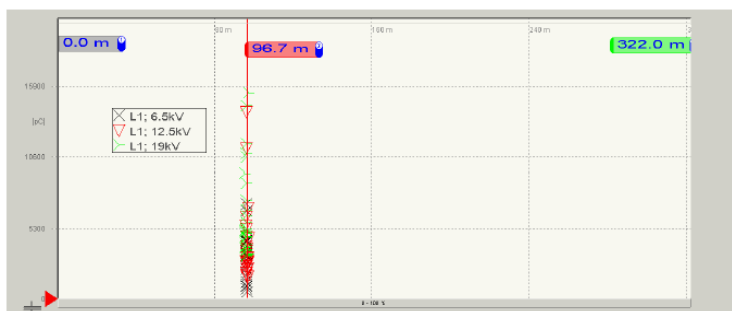

PD activity L1:

- very high PD activity in L1 at 97m.
- PD Inception voltage at $0.5U_0$
- PD up to 15.000pC at $1.5U_0$
- PD activity not influencing the TD result
- investigation required

Snapshot details

- 1 L1; truesinus@; 0.1 Hz; 06.12.2011 10:59:54; 6.5kV
- 2 L1; truesinus@; 0.1 Hz; 06.12.2011 11:01:33; 12.5kV
- 3 L1; truesinus@; 0.1 Hz; 06.12.2011 11:04:05; 19kV

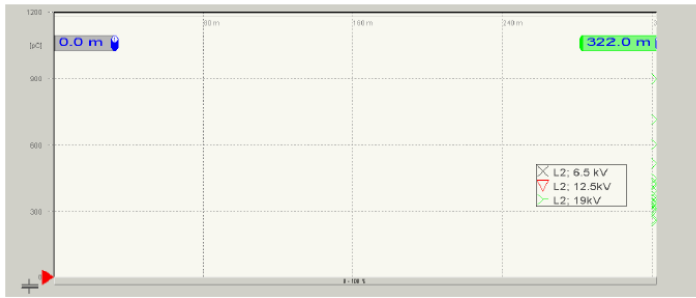

PD activity L2:

- No PD showing at 0.5U_o.
- No PD showing at 1.0U_o.
- Concentrated PD (up to ~900pC) at the far end termination 322m at 1.5U_o.

Snapshot details

- 1 L2; truesinus®; 0.1 Hz; 06.12.2011 11:10:42; 6.5 kV
- 2 L2; truesinus®; 0.1 Hz; 06.12.2011 11:17:06; 12.5kV
- 3 L2; truesinus®; 0.1 Hz; 06.12.2011 11:18:20; 19kV

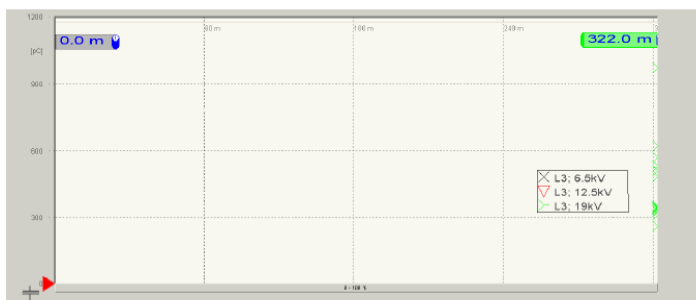

PD activity L3:

- No PD showing at 0.5U_o.
- No PD showing at 1.0U_o.
- Concentrated PD (up to ~900pC) at the far end termination 322m at 1.5U_o.

Snapshot details

- 1 L3; truesinus®; 0.1 Hz; 06.12.2011 11:23:20; 6.5kV
- 2 L3; truesinus®; 0.1 Hz; 06.12.2011 11:24:53; 12.5kV
- 3 L3; truesinus®; 0.1 Hz; 06.12.2011 11:26:01; 19kV

PD activity at nominal voltage 1.0 U_o and below

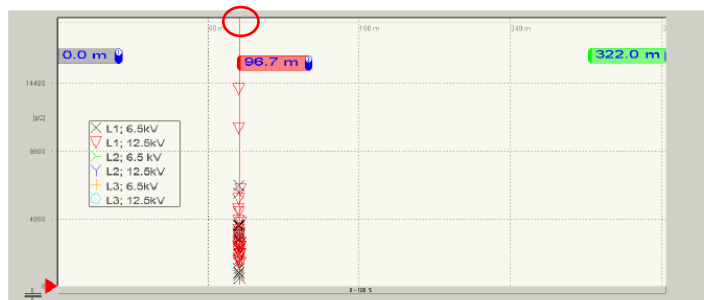

PD activity at nominal voltage 1.0 U_o and below

- Concentrated PD (up to 6.000pC) at the joint at 97m in L1

Snapshot details

- 1 L1; truesinus®; 0.1 Hz; 06.12.2011 10:59:54; 6.5kV
- 2 L1; truesinus®; 0.1 Hz; 06.12.2011 11:01:33; 12.5kV
- 3 L2; truesinus®; 0.1 Hz; 06.12.2011 11:10:42; 6.5 kV
- 4 L2; truesinus®; 0.1 Hz; 06.12.2011 11:17:06; 12.5kV
- 5 L3; truesinus®; 0.1 Hz; 06.12.2011 11:23:20; 6.5kV
- 6 L3; truesinus®; 0.1 Hz; 06.12.2011 11:24:53; 12.5kV

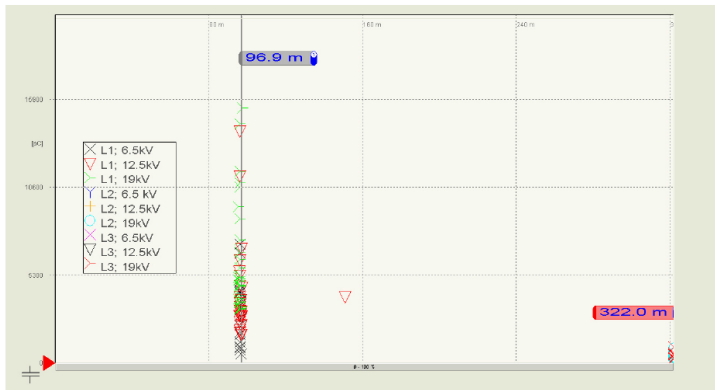

Overall PD activity

- Concentrated PD (up to 6.000pC) at the joint at 97m in L1
- PD activities in L2 and L3 at the far end termination

Snapshot details

- 1 L1; truesinus@; 0.1 Hz; 06.12.2011 10:59:54; 6.5kV
- 2 L1; truesinus@; 0.1 Hz; 06.12.2011 11:01:33; 12.5kV
- 3 L1; truesinus@; 0.1 Hz; 06.12.2011 11:04:05; 19kV
- 4 L2; truesinus@; 0.1 Hz; 06.12.2011 11:10:42; 6.5 kV
- 5 L2; truesinus@; 0.1 Hz; 06.12.2011 11:17:06; 12.5kV
- 6 L2; truesinus@; 0.1 Hz; 06.12.2011 11:18:20; 19kV
- 7 L3; truesinus@; 0.1 Hz; 06.12.2011 11:23:20; 6.5kV
- 8 L3; truesinus@; 0.1 Hz; 06.12.2011 11:24:53; 12.5kV
- 9 L3; truesinus@; 0.1 Hz; 06.12.2011 11:26:01; 19kV

PD interpretation

- L1: PD activity at 97m with PDIV at 0.5xU₀, up to 7.000pC at 0.5xU₀ and up to 15.000pC at 1.5xU₀
- L2 and L3: PD activity at the far end termination with PDIV at 1.5xU₀, up to 1.000pC.

As the PD activity in L1 does not reflect in the TD result, **surface discharges** at the joint are expected. The L-bow termination at the far end shall be investigated. These PD activities are also reflected in the STD at the voltage level of 1.5xU₀ in all phases.

The joint PD in L1 is much higher compared to the termination PD. After joint replacement, the PD at the termination in L1 is expected to become visible.

The high TD value of L3 is not associated with the PD activity.

12.1.4 Required action and conclusion – step 1

In conclusion, the joint in L1 should be replaced on urgent basis.

Investigation and joint dissection shall help to conclude the source of such high PD activity. The TD value, DTD as well as STD indicate good cable condition beside the indicated joint in L1.

In L2 and L3 investigations on the far end termination are recommended.

L3 shows very high TD value. The details of the STD as well as the growing TD trend during each voltage step indicate a **tracking most likely being associated to either a joint or a termination.**

Recommended approach:

The recommended way of investigation in this case is to replace the joint at 97m of L1. To trace the source of degradation in L3 the same joint at 97m shall be cut. If the TD behaviour is defined by the joint, then both cable parts should be of similar TD value.

part 1: cut point at 97m towards near end;

part 2: cut point at 97m towards far end

The analysis of both cable sections shall be done with TD measurement. If the leakage current is not associated with the joint, then one of the sections should indicate the same high TD result as shown in the total cable TD result of L3.

If this characteristic is given, the focus for further investigation shall be on the relevant cable termination.

After the replacement works, a repeating TD and PD diagnostic shall be done before the cable is put into service again.

12.1.5 Cable Dissection

Excavation was carried out near 97m in the following week.

The joint was cut and removed from the cable.



Damage was found at the joint, heat shrink tube; water under the outer protective heat shrink layer; strong corrosion on the cable sheath.

New joints were **installed** after removal of **the damaged joint**.

Retest on 31.01.2012

12.1.6 TD result 31.01.2012

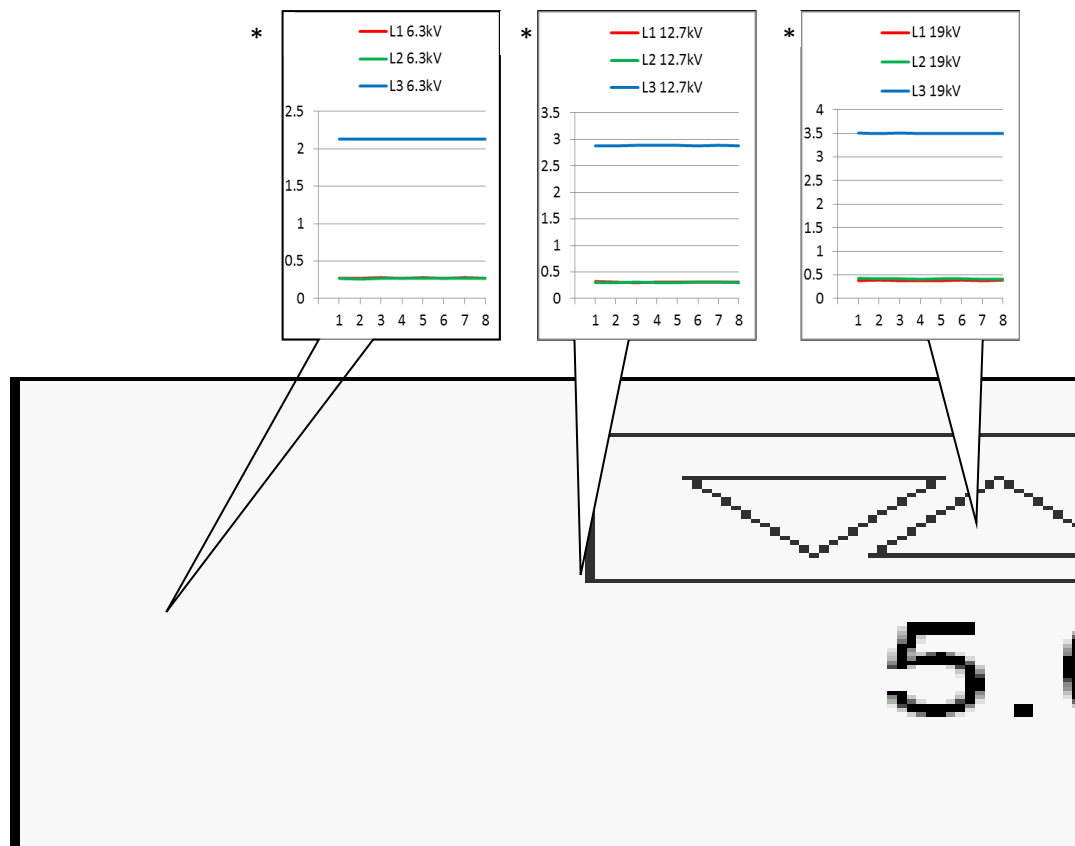

Cable with high operating risk

Evaluation

Name of Evaluation	XLPE 1,5U ₀
Criterion	Comment
TD(1.5xU ₀)>2.2	Cable with high operating risk
TD(1,5xU ₀)-(0.5U ₀)>1.0	Cable with high operating risk
TD(1.5xU ₀)>1.2	Highly service aged cable
TD(1.5xU ₀)<1.2	Cable can be returned to service
TD(1.5xU ₀)-(0.5U ₀)<0.6	Cable can be returned to service

- Overall cable condition... high operating risk
- Absolute TD values
 TD of L1, L2 very low ... good condition
 TD of L3 very high ... high operating risk
 (down from 21.929 to 2.886 @1.0Uo(12.7kV))
- TD standard deviation
 STD L1, L2 very low, stable condition ... dry condition
 STD L3 very low (reduced from 0.328 to 0.003)
- DTD (Delta TD)
 DTD of L1, L2 no increase of TD over the voltage
 DTD of L3 high value, increasing TD value with higher voltage
- TD trend analysis*
 L1, L2, L3 very stable trend condition
 stable trend behaviour
 (see *TD trend graphs)

12.1.7 Result comparison, before and after joint replacement

(Before) Table of Average tan delta value:

Voltage:	6.3kV	12.7kV	19kV
L1	0.632	0.772	0.979
L2	0.621	0.837	1.177
L3	11.914	21.929	35.980

(After) Table of Average tan delta value:

Voltage:	6.3kV	12.7kV	19kV
L1	0.273	0.309	0.384
L2	0.268	0.302	0.417
L3	2.131	2.886	3.503

(Before) Table of Standard Deviation:

Voltage:	6.3kV	12.7kV	19kV
L1	0.002	0.002	0.006
L2	0.005	0.006	0.010
L3	0.085	0.328	0.251

(After) Table of Standard Deviation:

Voltage:	6.3kV	12.7kV	19kV
L1	0.003	0.004	0.002
L2	0.002	0.006	0.005
L3	0.002	0.003	0.003

12.1.8 PD result 31.01.2012



Overall PD activity

- no more PD activity at 97m

PD Summary for L1, L2 & L3:

No more PD activities were found at the **97m** joint in L1, L2 & L3.

12.1.9 Required action and conclusion – step 2

In conclusion, L1 & L2 show very low TD value, Delta TD as well as Std. Deviation. No more PD activities in joint and terminations.

L3 still shows high TD value and Delta TD (but with very big improvement). The Std. Deviation has improved and become very stable.

For the future L3 need to be paid attention as the TD value remains in high operating risk. It is recommended to repeat diagnostic tests (measuring TD and PD) especially for L3 in regular basis and check the change in TD & PD over time.

12.2 Case Study H 2 - 5532

Key points:

- 2675m, 11kV, XLPE cable mixed with PILC
- TD values clearly indicate water ingress in a joint at L2
- Standard Deviation and TD trend analysis indicate water ingress in joint
- PD results allows to identify two joints with PD activity
- Water ingress eliminates the PD at the weak joint
- Monitored Withstand Test to confirm the presence of water in a joint

Our Ref:	H2 - 5532
Date of Test:	29.11.2013
Weather:	Sunny
Humidity:	60%
Requested by:	Electricity Company Hong Kong
Cable Location:	Hong Kong Island
Cable Type:	XLPE and PILC mixed cable, 11kV
Near end (From):	SKW Z/S SW39
Far end (To):	LEE CHUNG ST 36 SW5
Pulse Velocity (m/ μ s)	78.3
Cable Length:	2675m
Nominal Voltage:	11kV
Year Of manufacture:	N/A
Number Of Phases:	3
Soil Condition	moist
Joints	22
Test site:	SKW Z/S SW39
Used test equipment	BAUR Frida TD (for TD / MWT measurement) BAUR PD portable (for PD measurement)

12.2.1 Cable Layout

X 0	1	2	3	4	5	6	7	8
Z 0m	A A 7m	Z Z 96m	114m	A Z 148m	A Z 271m	A A 416m	631m	876m
R-1 7	1-1 89	1-3 18	3-3 34	3-2 123	2-1 145	1-3 215	- 245	-
Y-2	2-2	2-2	2-1	1-1	1-2	2-1	-	-
B-3 300 SQMM AX	3-3 240 SQMM CX	3-1 300 SQMM AP	1-2 300 SQMM AX	2-3 300 SQMM AX	3-3 300 SQMM AP	3-2 300 SQMM AX	- 300 SQMM AX	- 300 SQMM AX
NOV-1994 PIRE2006	2668m BICC1998	2578m UNKN 0	JAN-1977 2561m UNKN 0	JUL-1989 2527m UNKN 0	JUL-1989 2404m UNKN 0	JUN-1972 2259m UNKN 0	MAR-1988 2044m UNKN 0	MAR-1988 1791m UNKN 0
8	9	10	11	12	13	14	15	16
90	966m	988m	994m	1116m	A A 1358m	Z Z 1364m	1606m	A 1836m
- 22	1-2 6	2-1 122	- 242	2-2 6	2-3 242	- 230	2-	2-
2-3	3-2	3-2	1-3	1-3	3-2	3-2	-	3-
300 SQMM AX	- 300 SQMM AX	3-1 300 SQMM AX	1-3 300 SQMM AX	- 300 SQMM AX	3-1 300 SQMM CX	1-1 300 SQMM AX	- 300 SQMM AX	1-
MAY-1988 UNKN 0	1708m UNKN 0	APR-1988 1687m BICC1993	SEP-1993 1681m UNKN 0	APR-1988 1559m BICC1987	APR-1988 1317m PIRE2006	16-APR-2009 1311m BICC1987	MAY-1988 1066m BICC1987	JUN-1988 839m BICC1987
16	17	18	19	20	21	22	Y	
Z 5	A Z 1841m	Z A 2116m	Z A 2122m	A A 2361m	Z A 2415m	Z Z 2485m	2675m	
3-2 275	1-1 6	1-2 239	1-2 54	1-2 80	3-1 180	-R	-R	
2-1	3-3	3-1	3-1	2-3	2-2	-Y	-Y	
300 SQMM CX	1-3 300 SQMM AX	2-2 300 SQMM AX	2-3 300 SQMM AX	2-3 240 SQMM CX	3-1 240 SQMM CX	1-3 300 SQMM CX	-B	
13-MAY-2009 PIRE2006	874m JUL-1988 SUMI1988	559m 13-SEP-1991 BICC 0	553m MAY-1988 UNKN 0	314m 08-FEB-1999 BICC1998	260m 08-FEB-1999 BICC 0	180m JUN-1993 BICC 0	0m	

Cable length, 2675m
Mixed cable (PILC, XLPE)
Number of joints: 22

12.2.2 TD result

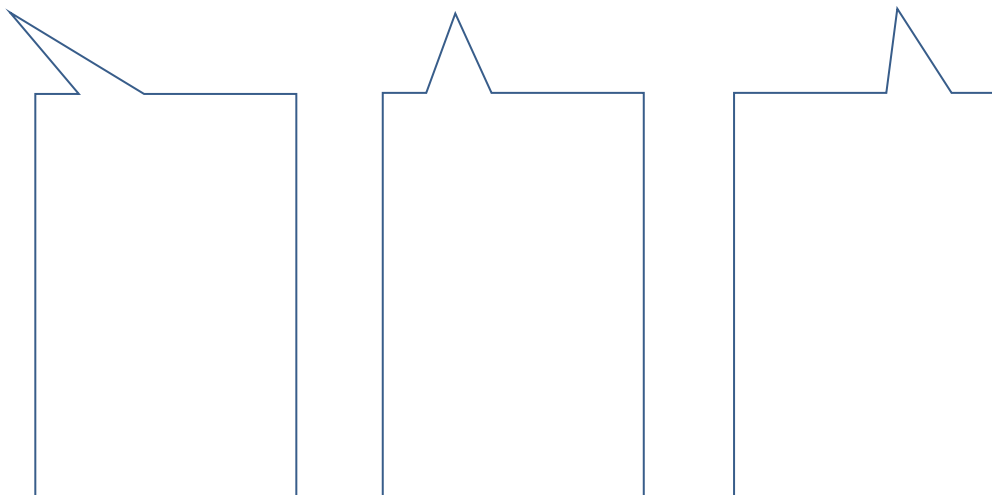

TD (E-3)	0.5U _o (kV)	U _o (kV)	1.5U _o (kV)
	3.5	6.5	10
L1	6.596	6.848	8.123
L2	36.717	105.207	218.644
L3	7.500	7.573	8.155

STDTD	0.5U _o (kV)	U _o (kV)	1.5U _o (kV)
	3.5	6.5	10
L1	0.035	0.024	0.049
L2	0.269	16.393	22.092
L3	0.011	0.040	0.054

Summary:

Phase	Step	Voltage kV	Avg. value tan delta	Std. Dev. [e-3]	Amount	Load nF
L1	1	3.2	6.596	0.035	8	1243
L1	2	6.5	6.848	0.024	8	1223
L1	3	9.7	8.123	0.049	8	1232
L2	1	3.2	36.717	0.269	8	1231
L2	2	6.5	105.207	16.393	8	1213
L2	3	9.7	218.644	22.092	8	1253
L3	1	3.2	7.5	0.011	8	1237
L3	2	6.5	7.573	0.04	8	1217
L3	3	9.7	8.155	0.054	8	1226

12.2.3 TD result interpretation

- Overall cable condition ... high operating risk
- Absolute TD values
TD of L1, L3 low values ... good condition
TD of L2 very high ... high operating risk
- TD standard deviation
STD L1, L3 very low, stable condition ... dry condition
STD L2 very high, unstable condition ... possible water ingress in joint(s)
- DTD (Delta TD)
DTD of L1, L3 no increase of TD over the voltage ... good condition
DTD of L2 high value, strongly increasing TD value with higher voltage, indication of voltage related leakage condition, tracking in joint(s)
- TD trend analysis
L1 and L3 rather stable trend condition, slight increasing trend behaviour
L2 large fluctuations, possible water ingress and current tracking
- Investigation of L2 is required

12.2.4 PD Result

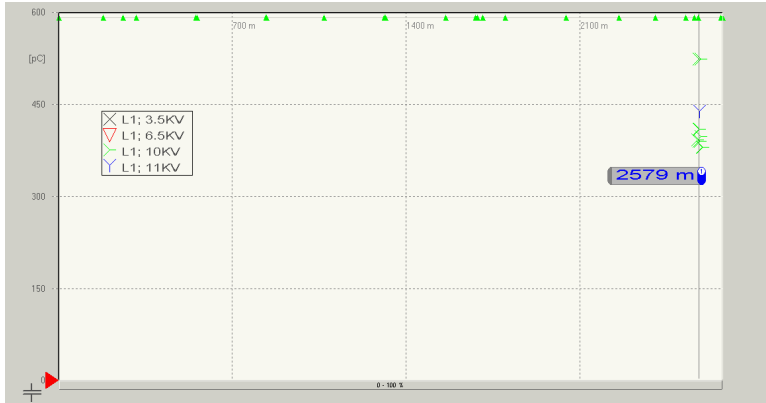

PD activity L1:

- PD activity in L1 at 2579m
- PD Inception voltage at 1.5U₀
- PD up to 500pC at 1.5U₀

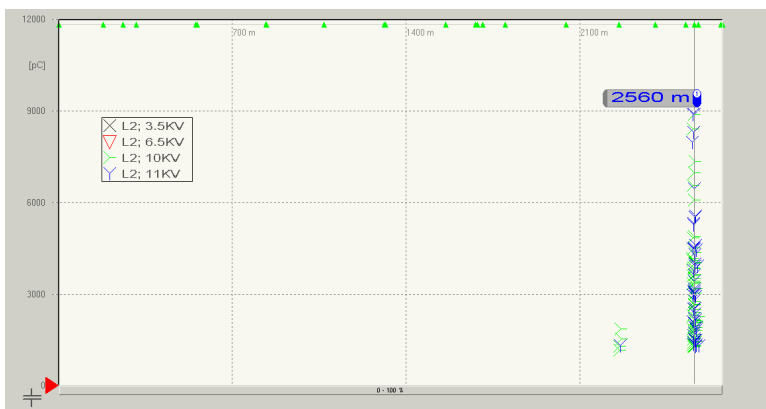

PD activity L2:

- PD activity in L1 at joint at 2560m
- PD Inception voltage at 1.5U₀
- high PD up to 9000pC at 1.5U₀

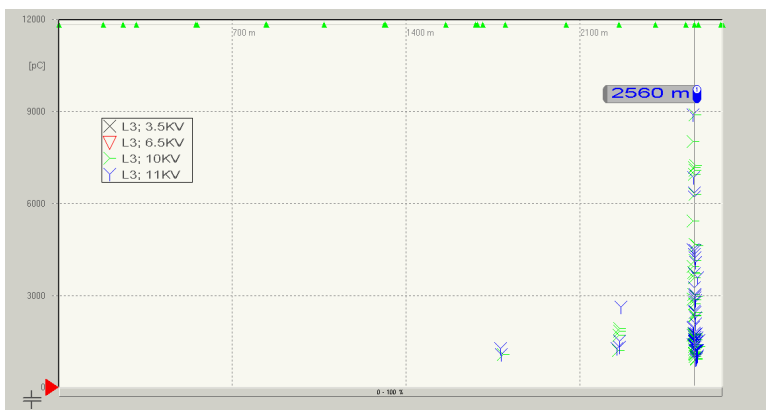

PD activity L3:

- PD activity in L1 at joint at 2560m
- PD Inception voltage at 1.5U₀
- high PD up to 9000pC at 1.5U₀

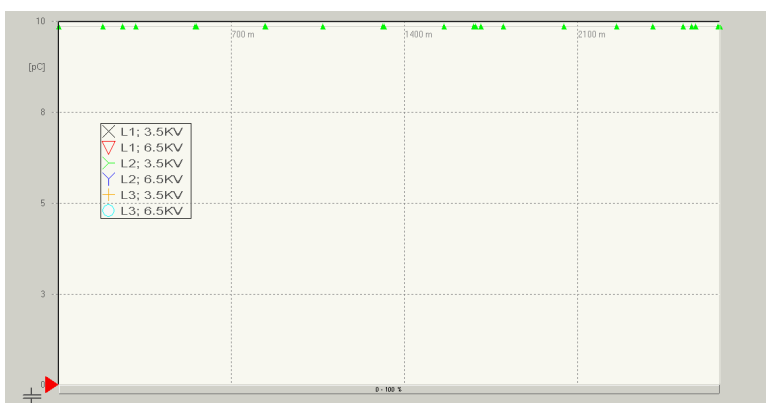

PD activity at nominal voltage 1.0 U₀ and below:

- no PD activities

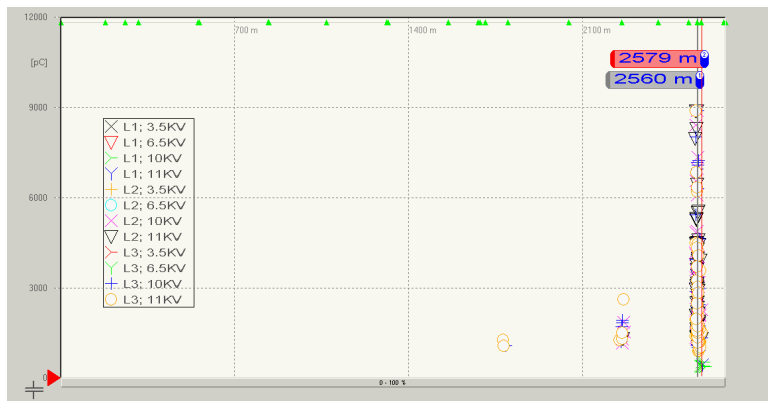

Overall PD activity

- two joints show PD activities
- PDIV above 1.0 U_o
- PD activity up to 9000pC

12.2.5 PD interpretation

- L1: PD activity at joint at 2579m with PDIV at 1.5U_o, up to 500pC
 L2 and L3: PD recorded at joints at 2560m with PDIV at 1.5U_o, up to 9000pC

No PD activity at operating voltage level. Joints with PDIV at above 1.0 U_o are to be considered as not very serious. This example shows, how important it is to perform an offline PD measurement up to 1.7U_o in order to recognize hidden defects.

The joints that show PD activities with PDIV at 1.5U_o and with a charge level of 9000pC shall be considered for mid-term replacement.

12.2.6 Diagnostic analysis

According to TD result, action is required for L2. This phase has very high mean TD and STDTD standard deviation. The TD trend analysis shows large fluctuations. Such high fluctuation in the TD time stability is mostly related to **at least one joint with influence of water ingress**. If moisture is present in a joint, PD activities could be largely attenuated or extinguished. In typically cases, **PD charge will be significantly reduced**, in some cases there could be no PD produced at all.

The TD measurement method, related technology and field experience has been well established. IEEE400.2-2013 is a clear guideline that defines the parameters of a TD measurement in terms of test voltage, test procedure, and evaluation criteria.

PD measurement is a well known method. Due to it's complexity in terms of the origin no evaluation criteria are available in standards. **If only PD measurement is used to assess the cable condition, this example shows that the cable's condition may be mis-interpreted and the defects related to water ingress and moisture would not be recognized.**

In order to enhance the assessment, it is recommended to perform a monitored withstand test (MWT) for 15 to 60 minutes. During the MWT test, VLF high voltage is applied for a period of time while at the same time, the TD value is monitored continuously. IEEE400.2-2013 recommend to perform withstand test for 30-60 minutes for aged cable. Based on Baur experience, it is recommended assessing the cable condition for only 15 minutes for this case.

Given that L2 TD value is so high and water ingress in a joint is expected, the MWT is used to confirm the conclusion. If the weakness is related to any other defect along the cable, the test voltage is expected to cause the weak spot to fail very soon in the withstand test period. However, if there is water ingress in joint, the cable may survive for a longer time. MWT test shall show the effect of the application of VLF voltage to such joints. Water ingress in a joint will start to show vaporizing effects and thus a decreasing TD value over time.

MWT test result

- L1 stable TD Δ t
- L2 shows extremely high TD value at the beginning and significant drop of the value over time TD Δ t
Indication of drying effect of VLF
- L3 slightly increasing TD Δ t
Aging condition

12.2.7 Conclusion and recommendation

L2 is in a high risk condition, L3 shown slight aging condition, and L1 is in good condition. It is challenging to localize the weak joint with TDPD measurement, because this cable system contains 22 joints, with mix a of XLPE and PILC cable sections. It can be considered to replace sections including the oldest sections and PILC sections. This would effect in removal of the old cable sections that would need to be replace anyway, and further reduce the number of joints. After cutting the cable and before installing a new section, the client can perform TD/PD tests toward cable near end and far end for further analysis.

For shorter cable sections, the method of TDR graph analysis to identify joints with water ingress will be applicable.

Furthermore, joints with water ingress usually are shown as cable sheath faults. Pre-location by bridge method and pin pointing with step voltage method is effective to locate wet joints.

By using MWT method, water ingress in joint was identified. It is important to combine the TD and PD measurement together to assess the overall condition of the cable, and as well as to pin point the weak spot.

12.3 Case Study H 3 - 5360

Key points:

- 740m, 11kV, XLPE cable, 9 joints
- Indication of joint with water ingress
- Very low PD activities
- Weak joint is reflected in TD result
- Water ingress (High Std Dev., decreasing trend pattern), No PD
- TDR analysis used to localize the joint with water ingress in joint Jt. 8 at 614m
- Low risk condition after joint replacement

Our Ref:	H3 - 5360
Date of Test:	1 st test on 16.04.2013 2 nd test on 10.05.2013
Weather:	Sunny
Humidity:	80%
Requested by:	Electricity Company Hong Kong
Cable Location:	Hong Kong Island
Cable Type:	AX, CX, 2CX
Near End (From):	SHAUKEIWAN ZONE S/S SW.64
Far End (To):	OI YAT HOUSE S/S SW.3
Pulse Velocity (m/μs)	85.3
Cable Length:	740m
Nominal Voltage:	11kV
Manufacturer:	NA
Year of Manufacture:	1998 (year of installation)
Number of Phases:	3
Soil Condition	moist
Joint position	total 9 joints
Test site:	SHAUKEIWAN ZONE S/S SW.64
Used test equipment	BAUR Frida TD (for TD measurement) BAUR PD portable (for PD measurement)

12.3.1 Cable Layout

X	0	1	2	3	4	5					
R-	130	-	47	-	76	-	83	A	[3-3]	10	[3-2]
Y-	-----										
B-	300 SQMM CX	-	300 SQMM AX	-	300 SQMM AX	-	300 SQMM AX	-	[2-2]	300 SQMM CX	[1-1]
	02-DEC-1992		02-DEC-1992		02-DEC-1992		APR-1988		19-OCT-2001		16
	BICC 0		BICC 0		BICC 0		UNKN 0		BICC2000		
0m	130m	177m	253m	336m	346m						
X	5	6	7	8	9	Y					
[3-2]	159	-	34	-	75	-	95	A Z	[1-1]	31	[1-R]
[2-3]	-----										
[1-1]	240 SQMM CX	-	300 SQMM CX	-	300 SQMM CX	-	300 SQMM CX	-	[2-2]	300 SQMM 2CX	[2-Y]
	16-AUG-1998		23-SEP-2000		12-SEP-2000		26-JUN-2000		25-SEP-2007		[3-B]
	BICC1998		BICC2000		BICC2000		BICC1999		SHAN2007		
346m	505m	539m	614m	709m	740m						

12.3.2 TD result 16.04.2013

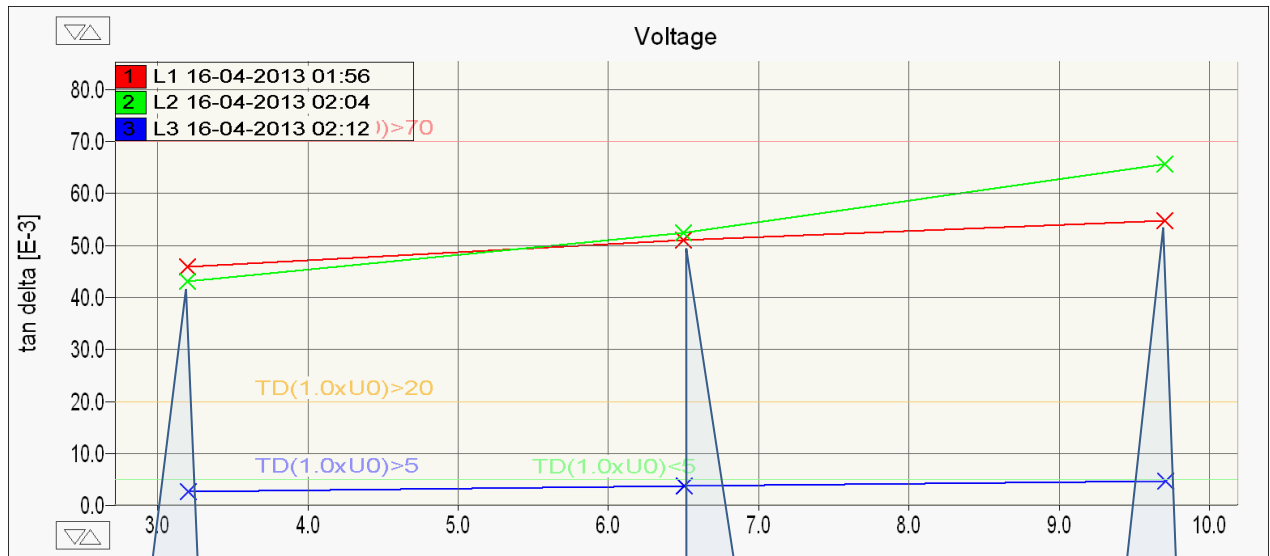

Level H High Risk

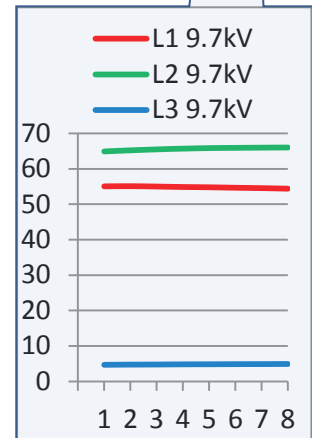
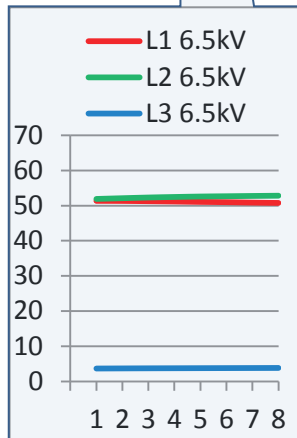
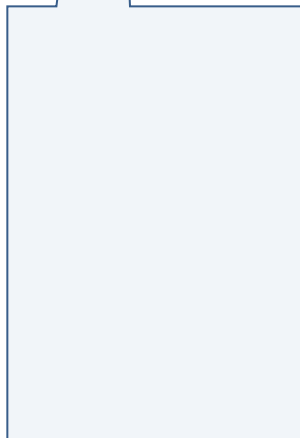

TD (E-3)	0.5U _o (kV)	U _o (kV)	1.5U _o (kV)	DTD
	3.5	6.5	10	
L1	45.97	51.10	54.79	8.81
L2	43.09	52.46	65.62	22.53
L3	2.643	3.748	4.808	2.16

STDTD	0.5U _o (kV)	U _o (kV)	1.5U _o (kV)
	3.5	6.5	10
L1	0.029	0.203	0.234
L2	0.040	0.302	0.373
L3	0.039	0.050	0.075

TD Summary:

Phase	Step	Voltage kV	Avg. value tan delta	Std. Dev. [e-3]	Amount	Load nF
L1	1	3.2	45.975	0.029	8	303.2
L1	2	6.5	51.106	0.203	8	301.1
L1	3	9.7	54.792	0.234	8	301.2
L2	1	3.2	43.09	0.040	8	306.1
L2	2	6.5	52.464	0.302	8	304.1
L2	3	9.7	65.627	0.373	8	304.6
L3	1	3.2	2.643	0.039	8	306.5
L3	2	6.5	3.748	0.050	8	304.5
L3	3	9.7	4.808	0.075	8	303.9

12.3.3 TD result interpretation

- Overall cable condition ... severe operating risk
- Absolute TD values
 - TD of L1, L2 very high ... high operating risk
 - TD of L3 low ... good condition
- TD standard deviation
 - STD L1, L2 high, unstable condition ... **indication of water ingress**
 - STD L3 low, stable conditions ... **dry condition**
- DTD (Delta TD)
 - DTD of L1, L2 strong increase of TD over the voltage
 - DTD of L3 slight increase of TD over the voltage
- TD trend analysis
 - L1 decreasing trend behaviour, **indication of water ingress in a joint**
 - L2 increasing trend behaviour, indication of tracking in a joint
 - L3 slight increasing trend behaviour, water tree aging
- Investigation of L1 and L2 required

12.3.4 PD Result 16.04.2014

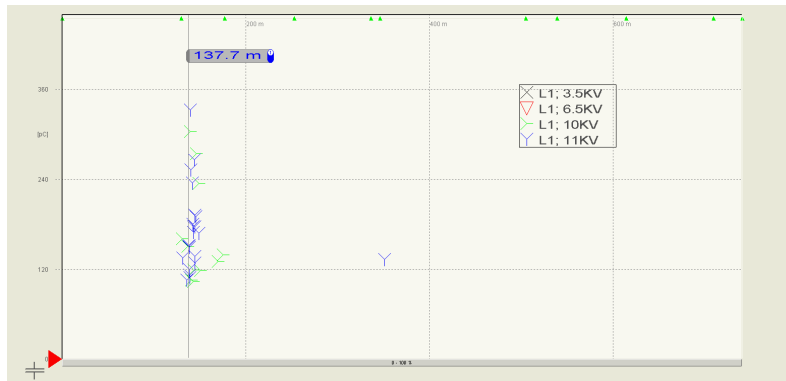

PD activity L1:

- PD activity in L1 near joint at 137m
- PD Inception voltage at $1.5U_0$
- PD up to 350pC at $1.5U_0$
- no serious PD activity



PD activity L2:

- minor PD activity in L2 near joint no. 2
- PD inception voltage at $1.7U_0$
- no serious PD activity

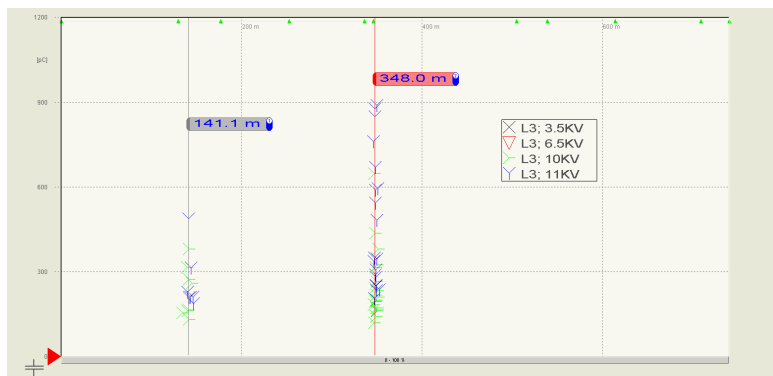

PD activity L3:

- PD activity near joint no. 1 at 141m
- PD inception voltage at $1.5U_0$
- PD up to 500pC
- PD activity at joint no. 5 at 348m
- PD inception voltage at $1.5U_0$
- PD up to 900pC

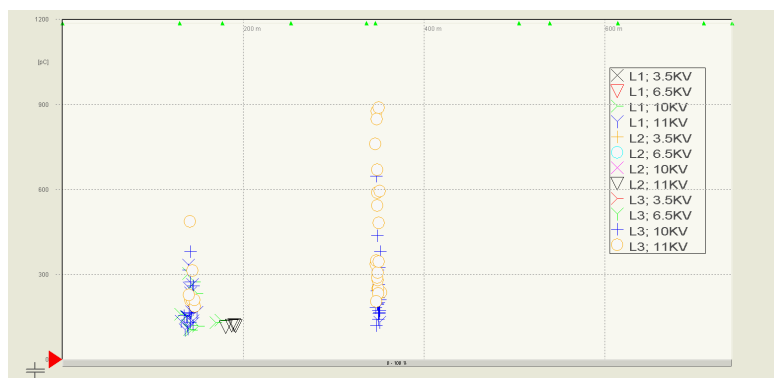

Overall PD activities:

- PD activity in all phases at 141m and 348m
- PD inception voltage at $1.5U_0$
- PD up to 900pC

PD interpretation

L1 and L2: PD activity at joint with insignificant level, PDIV at 1.5U_o

L3: PD recorded at joints at 148m with PDIV at 1.5U_o, up to 500pC and at 348m with PDIV at 1.5U_o, up to 900pC

No PD activity at operating voltage level. Joints with PDIV at above 1.0 U_o are to be considered as not very serious. This example shows, how important it is to perform an offline PD measurement up to 1.7U_o in order to recognize hidden defects.

The joints that show PD activities with PDIV at 1.5U_o and with a charge level of 1000pC shall be considered for long-term replacement.

12.3.5 Diagnostic Analysis

According to the TD test results, water ingress in at least one of the joints can be recognized based on the decreasing trend in L1. No serious PD activities are present. In L1, the drying effect when applying high voltage indicates moisture as the TD value decreases (negative trending).

In L2 shows increasing TD trend. It is an indication of tracking. The application of high voltage shows the effect, that the leakage current is gradually increasing. A partly conductive path is developing between screen and core inside a joint. If moisture is present in a joint, PD activities could be largely attenuated or extinguished. In typically cases, **PD charge will be significantly reduced**, in some cases there could be no PD produced at all.

This cable contained total of 9 joints and therefore it is challenging to pin point the weak joint(s).

Time Domain Reflectometry (TDR) method was used to **recongize irregular impedance changes** caused by the joint with water ingress. In this case, **the wet joint could be located successfully**.

By using TDR method, a pulse is injected into the cable system and the pulse reflection characteristic allows to recognize impedance changes between the core and sheath. Water ingress in a wet joint would likely cause a negative impedance change due to the reflection factor that is different from a dry joint.

By comparing the TDR graphs of three phases, shown in below figure, **joint 8 at 614m can be indentified to be an wet joint**. It shows a slight negative reflection with wide pulse width.

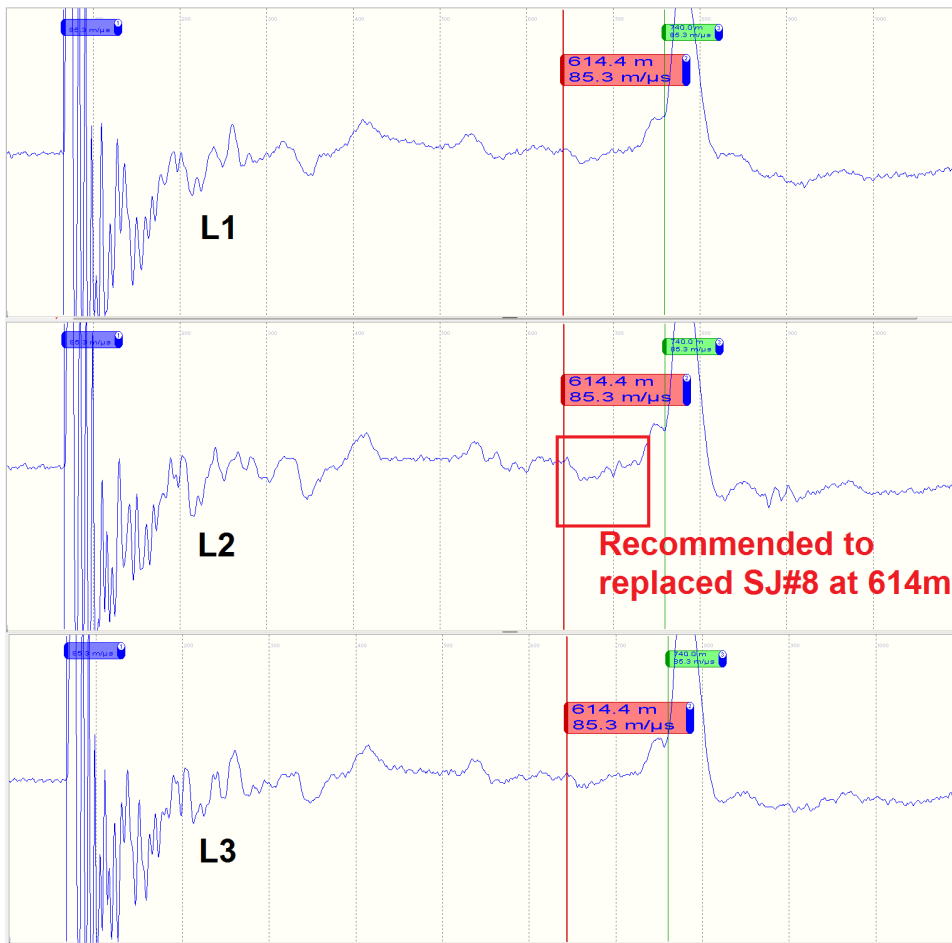

12.3.6 Recommended approach - action

One hour of monitor withstand test (MWT) was recommended in order to confirm the conclusion of a wet joint being the weak spot. MWT is a withstand test that monitor TD value in real time. If there is water ingress in joint, TD value would expect to decrease in the beginning and then slowly increase or stabilize. Moist joints very often do not break down during a VLF test.

TDR analysis indicates joint 8 at 614m with irregular impedance change. It was recommended to investigate/replace this particular joint.

On 10.05.2013, the joint 8 at 614m was replaced. TD and PD measurement was carried out after the repair.

12.3.7 TD result 10.05.2014, retest after joint replacement

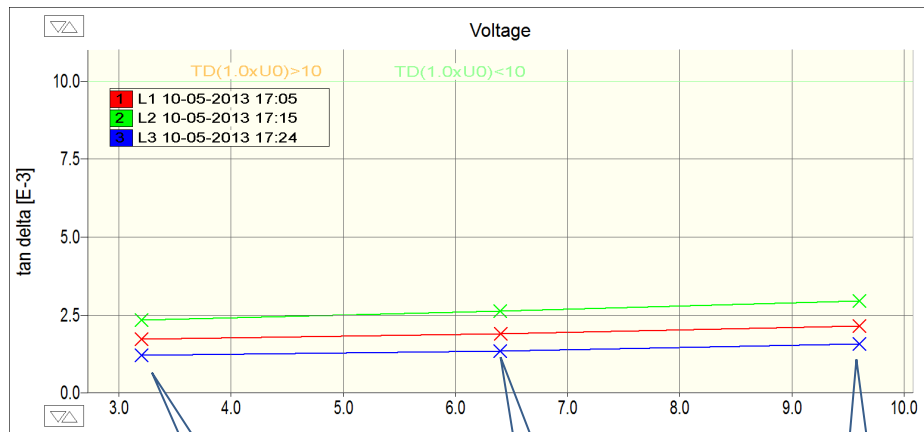

Level L ... Low Risk

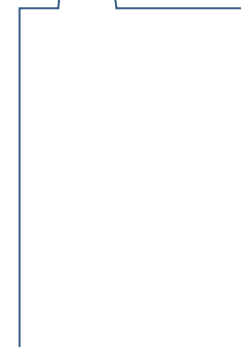
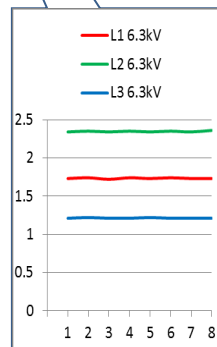

- Overall cable condition low operating risk
- Absolute TD values
TD of all phases very low ... good condition
- TD standard deviation
STD of all phases very low, stable condition ... dry condition
- DTD (Delta TD)
DTD of all phases no increase of TD over the voltage
- TD trend analysis
L1, L2, L3 very stable trend condition
stable trend behaviour

12.3.8 Result comparison, before and after joint replacement

Before

TD (E-3)	0.5U _o (kV)	U _o (kV)	1.5U _o (kV)
	3.5	6.5	10
L1	45.975	51.106	54.792
L2	43.090	52.464	65.627
L3	2.643	3.748	4.808

After

TD (E-3)	0.5U _o (kV)	U _o (kV)	1.5U _o (kV)
	3.5	6.5	10
L1	1.730	1.903	2.159
L2	2.348	2.623	2.962
L3	1.213	1.351	1.583

Before

STDTD	0.5U _o (kV)	U _o (kV)	1.5U _o (kV)
	3.5	6.5	10
L1	0.029	0.203	0.234
L2	0.040	0.302	0.373
L3	0.039	0.050	0.075

After

STDTD	0.5U _o (kV)	U _o (kV)	1.5U _o (kV)
	3.5	6.5	10
L1	0.007	0.007	0.011
L2	0.007	0.004	0.015
L3	0.003	0.003	0.019

12.3.9 PD result 31.01.2012 - after joint replacement

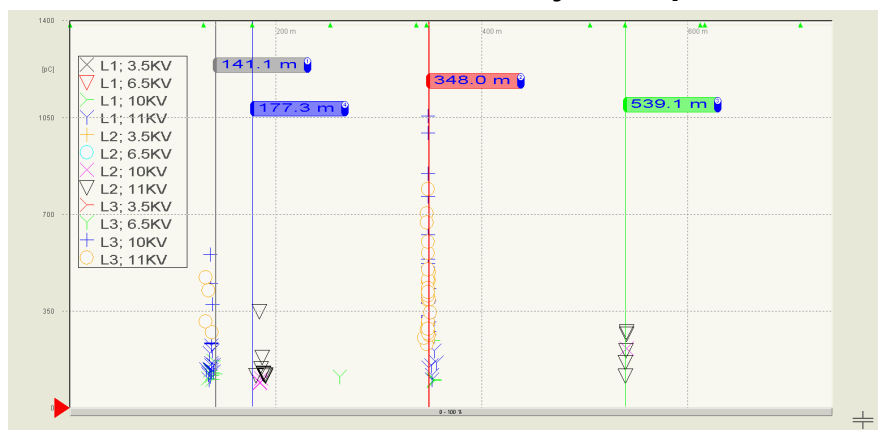

Overall PD activities:

- no PD activities at 1.0U_o and below
- PD activity in 4 joints
- PD inception voltage at 1.5U_o
- PD up to 900pC

12.3.10 Conclusion

TD and PD measurement was carried on the 11kV underground cable system. Cable was assessed to be in very high risk condition in first test, and required immediate action. TD values were very high and instable. PD activities were recorded but they were not related to the weak spot.

TDR analysis was used. By analysing the pulse shape the weak joint could be identified and was replaced. After the repair the test results show that the cable is in low risk condition and safe to return to operation.

After joint replacement, cable system is again in good condition and it can return to safe operation. As general routine, it is recommended to re-test the cable after five years to re-assess its condition.

12.4 Case Study H 4 - 4285

Key points:

- 1449m , 11kV, XLPE cable with WTPCS, 13 joints,
- Water tree aging in Water Tree Prone Cable Section
- Replacement of WTPCS shows improvement in TD value
- TD results by sectioning the cable (High TD in WTPC, 2nd Section)
- Water ingress in joint Jt. 1 (High Std Dev.), No PD
- Water tree development in joint Jt. 1 area
- Dissection shows water tree and electrical tree

HEC Ref:	H4 - 4285
Date of Test:	13.07.2011
Weather:	Fine
Humidity:	45%
Requested by:	Electricity Company Hong Kong
Cable Location:	Hong Kong Island
Cable Type:	XLPE
Near end (From):	Kennedy Road Zone S/S SW34
Far end (To):	NEW BANK OF CHINA BLDG L1 WEST SW12
Pulse Velocity (m/ μ s)	80.6
Cable Length:	1449m
Nominal Voltage:	11kV
Year Of Manufacture:	1985(WTPC), 1989(WTPC), 2004, 2005
Number Of Phases:	3 core
Soil Condition	n/a
Joint positions	13 joints
Test site:	Kennedy Road Zone S/S SW34
Carried out tests: VLF TD ... BAUR Frida TD VLF PD ... BAUR Frida TD + PD portable	

12.4.1 Cable Layout / Structure

hvf_p_4285
 EHT 4285 (11kV) NEW BANK OF CHINA BLDG L1 WEST (X) TO KENNEDY RD ZONE S/S (Y) 13-FEB-2010

Rated Voltage	Material Code	Size	Length(m)	Remarks
11	AX	300sqmm	1049	This cable contains Water Tree Prone Cable Section(s) (WTPCS), VLF TEST REQUIRED
11	CX	300sqmm	405	

INT	MAKE	DATE	WEATHER	LOG	ENGINEER	JOINTER	SWITCH	REMARKS	MAP	CO-ORDINATE	SKETCH NO
X	RAYR	28-MAR-2004	FINE	C	6127	S5635	12		11sw14A1	834642.213, 815396.966	0610/2004
1	RAYR	06-JUN-1989	UNKNOWN		4217				11sw09C3	834661.149, 815638.180	1072/1990
2	RAYR	05-JUN-1989	UNKNOWN		4217				11sw14A1	834800.566, 815397.304	1072/1990
3	RAYR	18-MAY-2005	RAZN		5122	S5005			11sw14A2	835001.354, 815472.283	1223/2005
4	RAYR	18-MAY-2005	RAZN		5122	S5159			11sw14A2	835006.056, 815471.948	1223/2005
5	RAYR	17-AUG-2004	FINE		5122	S5005		POSITION & DETAILS UNKNOWN 2005/1223	11sw14A2	835049.217, 815461.923	1836/2004
6	RAYR	17-AUG-2004	FINE		5122	S5002		MECH SPLIT-TYPE BLOCKED CONNECTORS	11sw14A2	835058.953, 815459.418	1836/2004
7	RAYR	17-AUG-2004	FINE		5122	S5159		MECH SPLIT-TYPE BLOCKED CONNECTORS	11sw14A2	835064.199, 815458.668	1836/2004
8	RAYR	23-OCT-1985	UNKNOWN		2117	J 712			11sw14A2	835133.346, 815457.460	0 /
9	RAYR	JUN-1989	UNKNOWN		4217				11sw14A1	835276.670, 815440.307	1072/1990
10	RAYR	JUN-1989	UNKNOWN		4217				11sw14A2	835174.806, 815339.947	1072/1990
11	RAYR	11-AUG-2004	FINE		5122	S5005		MECH SPLIT-TYPE BLOCKED CONNECTORS	11sw14A2	835122.873, 815305.295	1755/2004
12	RAYR	11-AUG-2004	FINE		5122	S5159		MECH SPLIT-TYPE BLOCKED CONNECTORS	11sw14A4	835113.568, 815296.810	1755/2004
13	RAYR	JUN-1989	UNKNOWN		4217	S5002			11sw14A4	835101.644, 815288.187	1072/1990
14	RAYR	14-MAY-2005	FINE		5839	J1386			11sw14A4	835032.315, 815236.491	1337/2005
15	RAYR	03-MAY-2005	FINE		4392	S5635			11sw14A4	835060.648, 815120.356	1336/2005
Y	RAYR	13-MAY-2005	UNKNOWN	C	5639	J 407	34		11sw14C2	835129.457, 814985.527	1337/2005

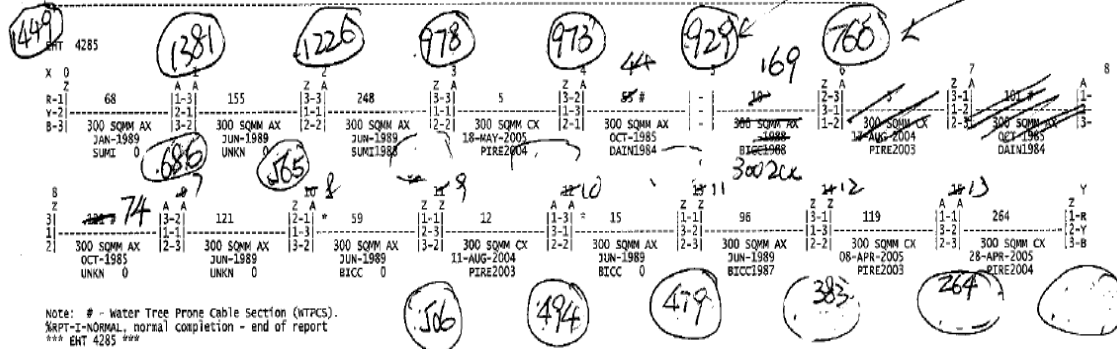

Overview:

The cable in between Kennedy Zone S/S and New Bank of China had tripped. It was required to find the root cause of this problem by using VLF testing and Diagnostics equipment. TD & PD measurements were performed and high TD values were recorded. The suspected sections were replaced by the new cable. However, one joint failed after two weeks and it was unexpected. After the investigation, it was found that this joint was located in the WTPCS and this has caused the joint to fail.

12.4.2 History

On 7 July 2011, cable in between Kennedy Zone S/S Sw.34 and New Bank of China tripped and cable fault was found in cable body (XLPE insulation) of L2 & L3. The fault between Jt.7 & Jt.8 was repaired immediately.

On 9 July 2011, 15mins VLF test was performed with 2.0xUo and L1 & L2 failed the test. The 2nd fault was located in the same section (between Jt.7 & Jt.8).

The fault area was investigated in detail. The section was considered to be a water tree prone cable section (WTPCS). A serious corrosion on the cable sheath and some signs of water ingress were observed. Therefore, it was decided to replace a 169m cable from joint HJ#1 to joint HJ#2 which also covers Jt.7 & Jt.8.

On 13 July 2011, 15mins VLF test was performed @2Uo and all 3 phases passed TD, PD and VLF test.

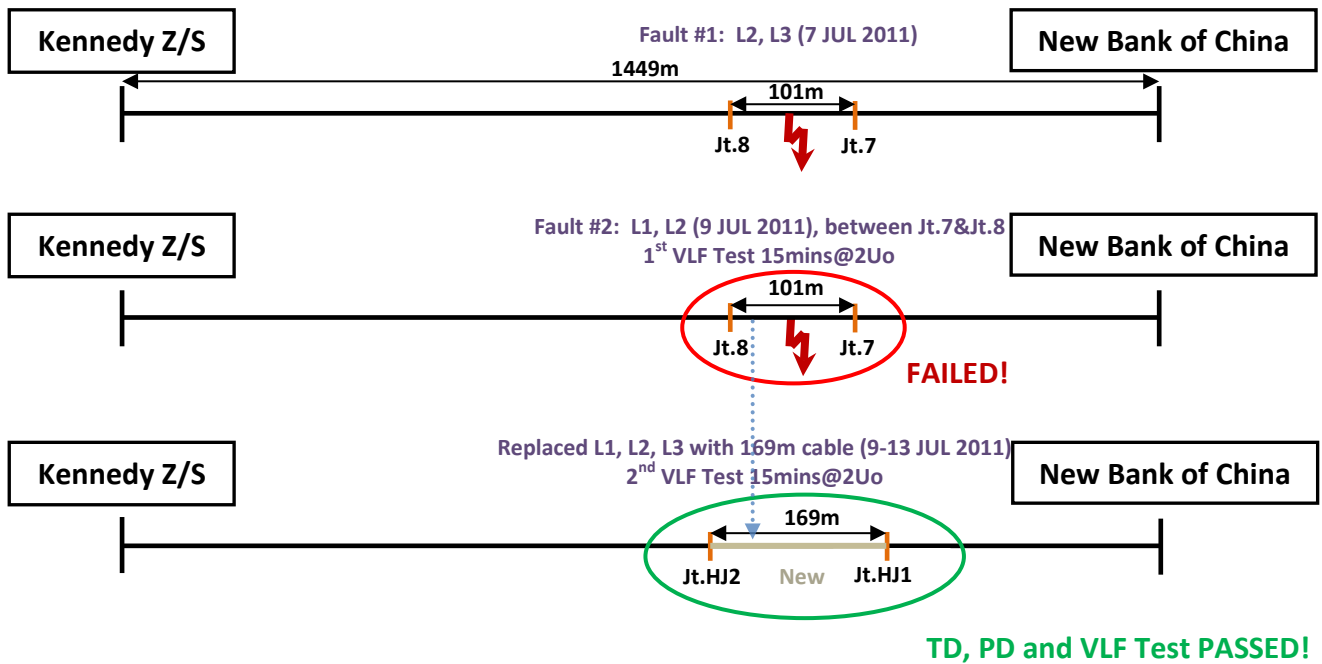

12.4.3 TD & PD Measurement results

TD Result recorded on 9 JUL 2011

- after fault #1 repair
- before VLF test

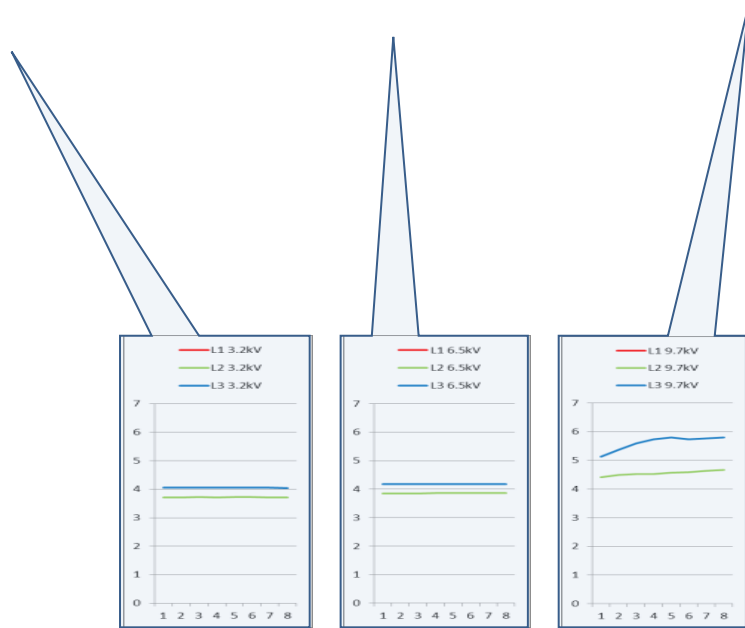

Table of Average tan delta value MTD:

Voltage:	3.2kV	6.5kV	9.7kV
L2	3.713	3.855	4.550
L3	4.052	4.174	5.620

Table of Standard Deviation:

Voltage:	3.2kV	6.5kV	9.7kV
L2	0.003	0.006	0.076
L3	0.005	0.003	0.225

Summary:

Phase	Step	Voltage kV	Avg. value tan delta	Std. Dev. [e-3]	Load nF
L2	1	3.2	3.713	0.003	8
L2	2	6.5	3.855	0.006	8
L2	3	9.7	4.550	0.076	8
L3	1	3.2	4.052	0.005	8
L3	2	6.5	4.174	0.003	8
L3	3	9.7	5.620	0.225	8

- No PD measurement was carried out.
- VLF test @2U₀, 15mins was carried out before putting into service.
- **L1 & L2 failed**, -> 169m cable replaced on 9-13 JUL 2011

TD result interpretation:

Overall cable condition ... high operating risk

Absolute TD values

TD of L2, L3 high values ... high operating risk

TD standard deviation

STD L2, L3 increased values at 1.5Uo ... rather unstable conditions

DTD (Delta TD)

DTD of L2, L3 increasing TD over the voltage ... indication of water tree aging

TD trend analysis

L2 and L3 rather stable trend condition at 0.5Uo and 1.0Uo, slight **increasing trend behaviour at 1.5Uo ... indication of water tree aging**

- VLF test was expected to fail
- TD of L1 was not observed as only L2 & L3 failed on 7 JUL 2011

12.4.4 TD Result recorded on 13 JUL 2011

- after fault #2 repair
- section replacement

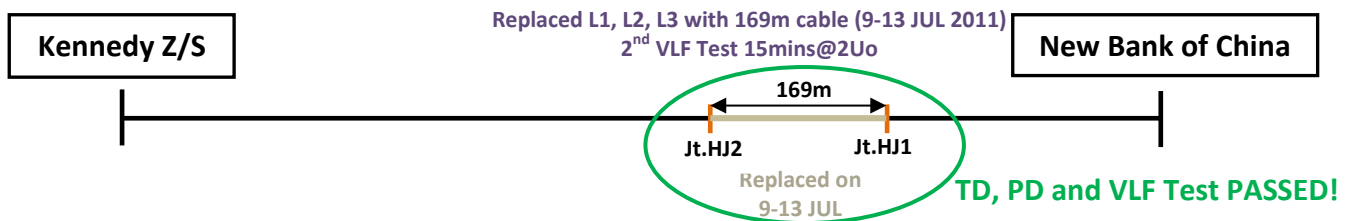

TD result 13.07.2011

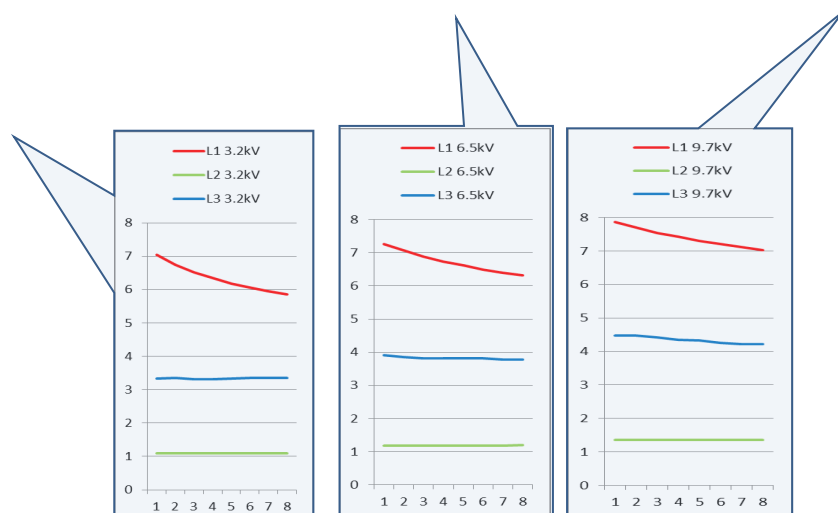

The results of L1, L2 & L3 were obtained after the replacement of cable section on 13 JUL 2011. L1 indicates very high TD values (not recorded on the 9 JUL 2011). L2 improves significantly, the TD value @1.5Uo dropped from 4.5xE-3 to 1.3xE-3. L3 improves slightly, the TD value @1.5Uo dropped from 5.6xE-3 to 4.3xE-3.

Average TD values of L1 & L3 are still at high operating risks. The delta TD value in L1 is approx. 1.1xE⁻³ which represents 'highly service aged condition'. The delta TD value in L2 is approx. 0.3xE⁻³ which represents 'good condition'. The delta TD value in L3 is approx. 1.0xE⁻³ which 'highly service aged condition'; therefore it is necessary to investigate the cables in further details. The TD Standard Deviation of L1 & L3 indicates water ingress in at least one of the joints. The decreasing TD stability Trend of L1 & L3 is a further indication of humidity or moisture is present.

Table of Average tan delta value:

Voltage:	3.2kV	6.5kV	9.7kV
L1	6.352	6.727	7.405
L2	1.087	1.185	1.354
L3	3.340	3.824	4.342

Table of Standard Deviation:

Voltage:	3.2kV	6.5kV	9.7kV
L1	0.385	0.310	0.271
L2	0.001	0.006	0.003
L3	0.013	0.035	0.099

Summary:

Phase	Step	Voltage kV	Avg. value tan delta	Std. Dev [e-3]	Load nF
L1	1	3.2	6.352	0.385	8 636.2
L1	2	6.5	6.727	0.310	8 636.8
L1	3	9.7	7.405	0.271	8 630.1
L2	1	3.2	1.087	0.001	8 638.4
L2	2	6.5	1.185	0.006	8 638.9
L2	3	9.7	1.354	0.003	8 632.3
L3	1	3.2	3.340	0.013	8 640.7
L3	2	6.5	3.824	0.035	8 641.4
L3	3	9.7	4.342	0.099	8 634.7

- L1... high DTD, very high water tree aging, very high operating risk, signs of **water ingress in at least one of the joints**
- L2... stable, considered as reference
- L3... high DTD, high water tree aging, high operating risk, signs of water ingress in at least one of the joints (less than L1)

12.4.5 PD measuring result after replacement of 169m cable section on 13 JUL

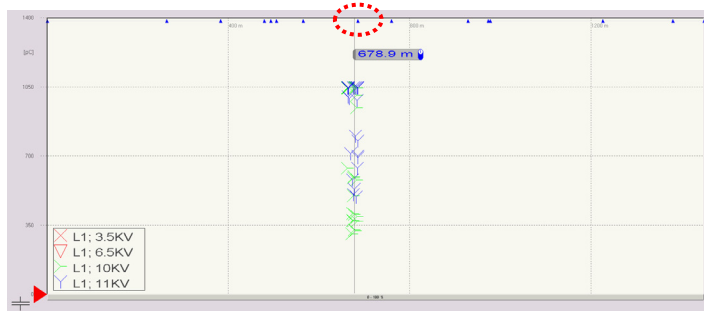

Figure 112 PD result of Phase 1 13.07.2011

PD activity in L1:

- PD activity at joint at 679m.
- PD Inception Voltage at 1.5U₀
- PD up to 1000pC at 1.5U₀/1.7U₀.

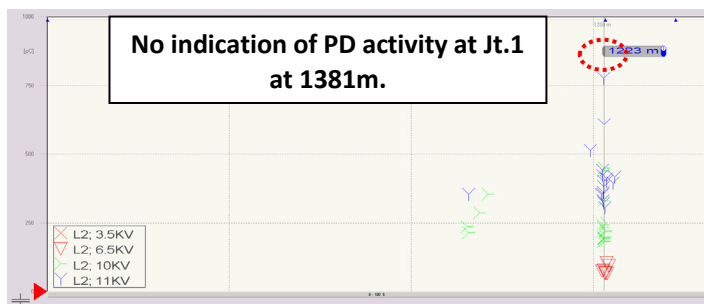

Figure 113 PD result of Phase 2 13.07.2011

PD activity in L2:

- PD activity in joint at 1223m
- PD Inception Voltage at 1.0U₀
- PD up to 800pC at 1.7U₀.

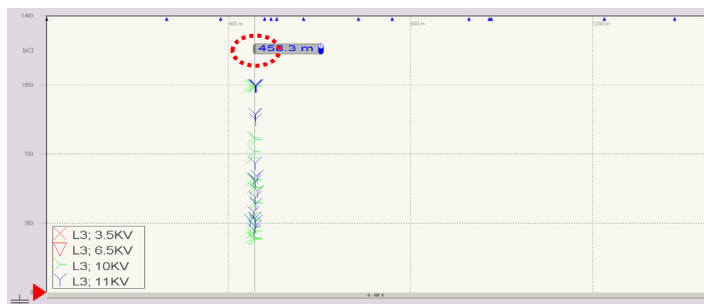

Figure 114 PD result Phase 3 13.07.2011

PD activity in L3:

- PD activity in XLPE cable body at 458m
- PD Inception Voltage at 1.5U₀
- PD up to 1000pC at 1.7U₀.
- the location needs to be analysed if an external damage or an electrical tree is present or a hidden joint is representing the PD.

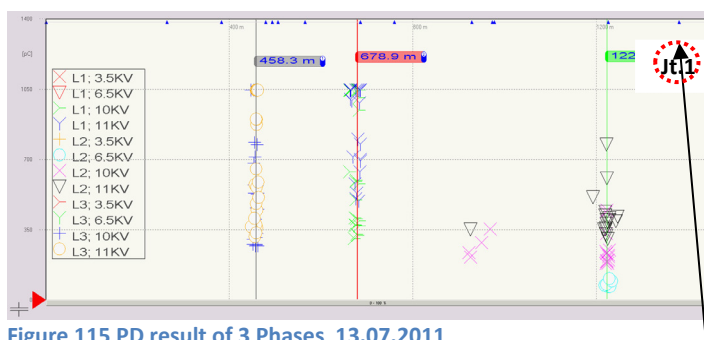

Figure 115 PD result of 3 Phases 13.07.2011

Overall PD activity:

- Two joints show PD activity
- PDIV at 1.0U₀ at 1223m
- PDIV at 1.5U₀ at 679m, 458m
- 458m is along the cable, no joint, investigation required

No PD at Joint #1 at 1381m!

After TD and PD measurements, 15mins VLF test was done @2Uo. **All 3 phases passed the test.** According to the power utilities regulations, the cables belong to Category A-1 type cable and they were judged to be M (Medium Risk Condition). It was ordered to retest after 3 years of operation (13 JUL 2014).

12.4.6 TD PD Diagnostic Summary

- L1 & L3 are in high operating risk condition
- TD DTD values indicate high increase of TD over the voltage
- Indication of severe water tree aging in L1 & L3, signs of water ingress in at least one of the joints
- PD measurement confirmed that water tree aging is causing the high TD value
- Several joints also indicated PD activity
- Jt.1 at 1381m did not show any PD activity

12.4.7 Cable fault on 30 JUL 2011

- After two weeks of normal operation.
- L3 failed at joint Jt.1, located 1381m away from Kennedy Zone S/S Sw.34.

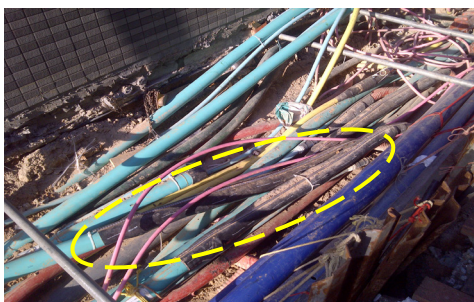
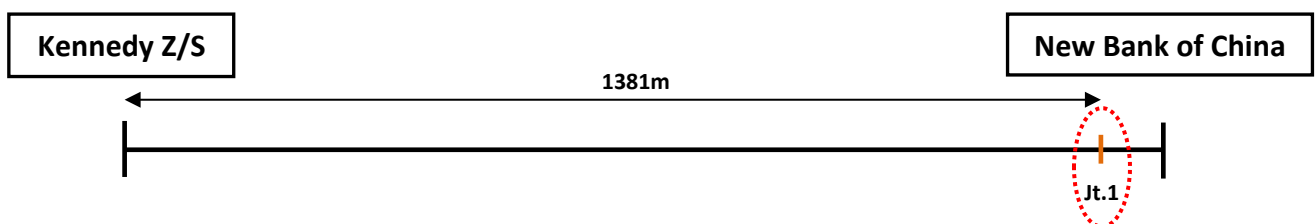

Figure 7 Picture of joint before dissection

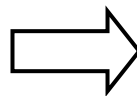

Figure 8 Picture of dissected joint Jt.1
(See page12 for further details)

This cable failure was unexpected. Detailed investigation had to be performed.

Step 1: Cable was cut at 1381m

Step 2: Both sections of the cables were tested individually

(1st section: 1381m, 2nd section: 68m)

12.4.8 TD Measurement on 31 JUL 2011

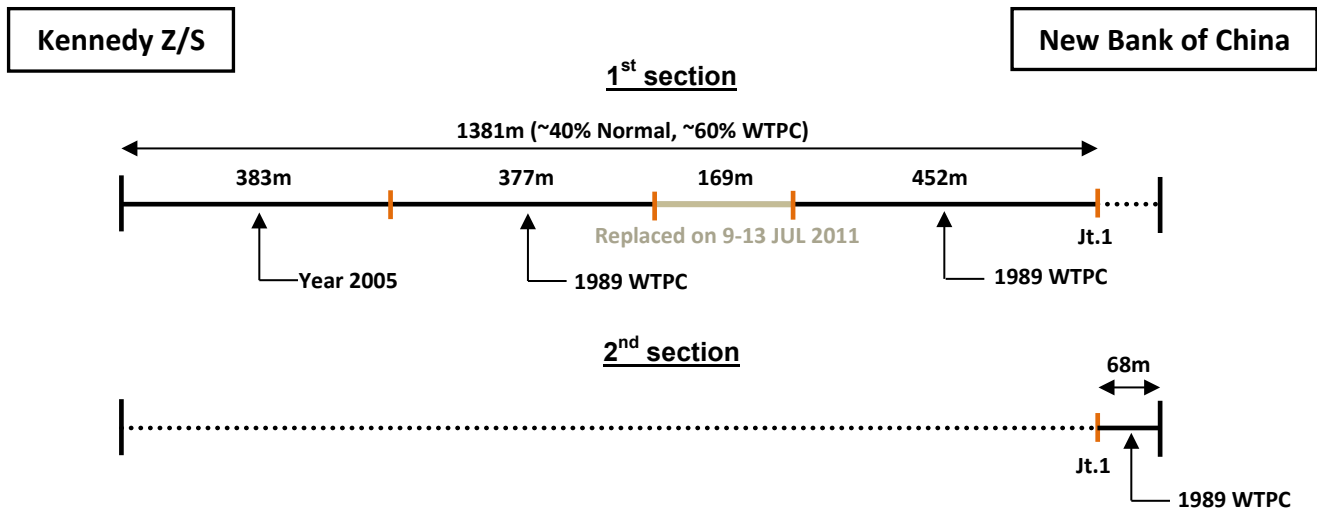

1st Section: TD Result recorded on 31 JUL 2011

- 1381m, several sections with WTPC included, 610nF

TD result 31.07.2011,
1381m section

Full length cable results of all 3 phases were obtained after the cable failure on 30 JUL 2011. **Average TD values of L1 & L3 are rather high.** L1 indicates most unstable behaviour but improved significantly due to the eliminated influence of the joint Jt. 1. L2 remained the same. L3 also improved significantly. Standard Deviation indicates water tree aging in L3. The dissection indicates water marks on the surface of the XLPE in the termination and water tree development in L3. It can be assumed that the area around the joint is also affected by high water tree aging. The delta TD value in L1 is approx. 0.9×10^{-3} which represents 'highly service aged condition'. Therefore, it is necessary to investigate the cables in further details. The TD value of the whole section is an integral indication of 40% non-WTPC and **60% WTPC section.**

Cable with high operating risk!

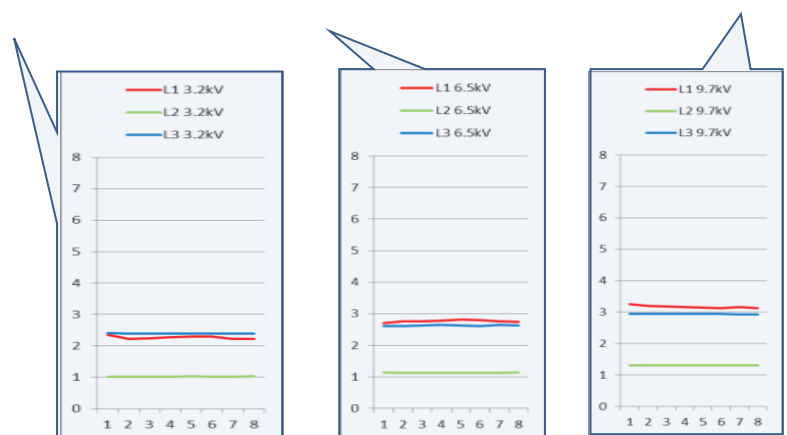

Table of Average tan delta value:

Voltage:	3.2kV	6.5kV	9.7kV
L1	2.270	2.768	3.165
L2	1.024	1.129	1.307
L3	2.401	2.628	2.941

Table of Standard Deviation:

Voltage:	3.2kV	6.5kV	9.7kV
L1	0.048	0.031	0.042
L2	0.002	0.008	0.003
L3	0.003	0.007	0.010

Summary:

Phase	Step	Voltage kV	Avg. value tan delta	Std. Dev. [e-3]	Load nF
L1	1	3.2	2.270	0.048	8
L1	2	6.5	2.768	0.031	8
L1	3	9.7	3.165	0.042	8
L2	1	3.2	1.024	0.002	8
L2	2	6.5	1.129	0.008	8
L2	3	9.7	1.307	0.003	8
L3	1	3.2	2.401	0.003	8
L3	2	6.5	2.628	0.007	8
L3	3	9.7	2.941	0.010	8

- L1... high DTD, high water tree aging, high operating risk
- L2... stable, considered as reference
- L3... high DTD, high water tree aging, high operating risk

2nd Section: TD Result recorded on 31 JUL 2011

- 68m, 1 section with WTPC and no joint, 27nF

Cable with high operating risk!

TD result
31.07.2011

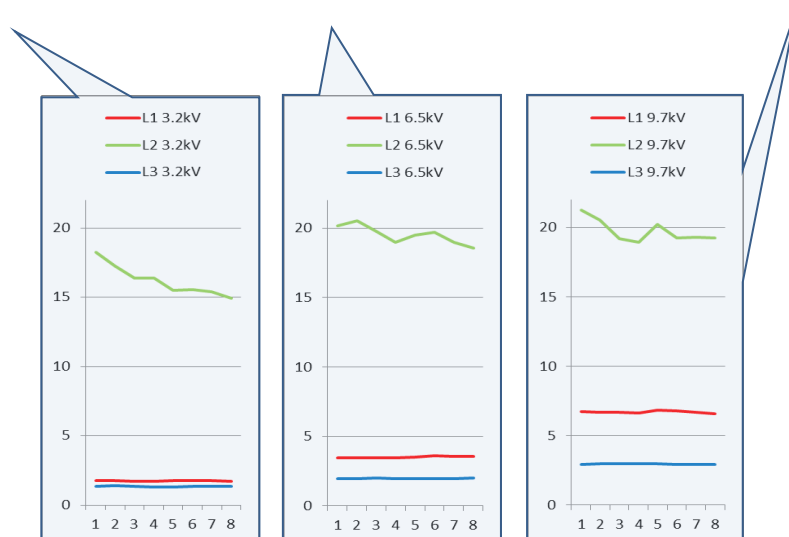

The results of the last 68m section (distance from the cut-point to the termination) of all 3 phases were also obtained after the cable failure on 30 JUL 2011. The TD results changed due to the cable length and homogenies cable composition (WTPCS without joints) and show that all cables have high operating risk and L2 has the worst result. The delta TD values for all 3 phases are extremely high which is far beyond the acceptable limit and high water tree aging and water ingress in a joint in L2 is to be expected; therefore it is necessary to investigate the cables in further details.

Table of Average tan delta value:

Voltage:	3.2kV	6.5kV	9.7kV
L1	1.745	3.507	6.702
L2	16.242	19.529	19.755
L3	1.336	1.970	2.815

Table of Standard Deviation:

Voltage:	3.2kV	6.5kV	9.7kV
L1	0.021	0.052	0.074
L2	1.037	0.624	0.771
L3	0.028	0.024	0.041

Summary:

Phase	Step	Voltage kV	Avg. value tan delta	Std. Dev. [e-3]	Load nF	
L1	1	3.2	1.745	0.021	8	27.5
L1	2	6.5	3.507	0.052	8	27.3
L1	3	9.7	6.702	0.074	8	27.4
L2	1	3.2	16.242	1.037	8	27.3
L2	2	6.5	19.529	0.624	8	27.1
L2	3	9.7	19.755	0.771	8	27.1
L3	1	3.2	1.336	0.028	8	27.5
L3	2	6.5	1.970	0.024	8	27.3
L3	3	9.7	2.815	0.041	8	27.3

- L1... high DTD, high water tree aging, high operating risk
- L2... very high TD value & DTD, very high water tree aging, very high operating risk, high water tree aged condition of the cable section (Sumitomo) from the far end to joint Jt. 1 can only be recognized in this way because of the relatively small portion <5% of total cable length
- L3... high DTD, high water tree aging, high operating risk
- **Jt.1 failed at 1381m on 30 JUL 2011**

12.4.9 Joint dissection



Rusty noted inside wraparound recovered from site



Fault point on L3 at Sumitomo

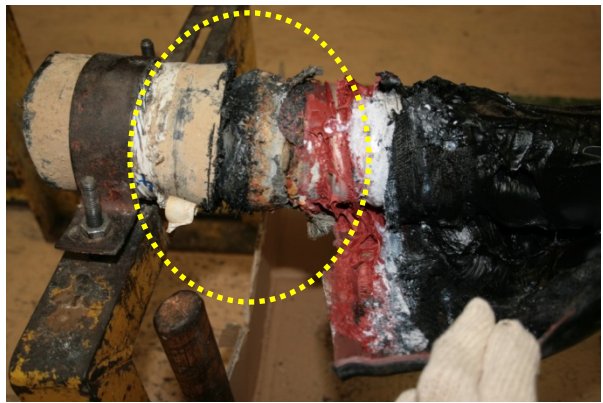

Water found in cable during joint recovery. CAS corroded at Sumitomo cable side inside inner sleeve



Water sign noted in insulation screen



Suspected water tree developed near to fault point

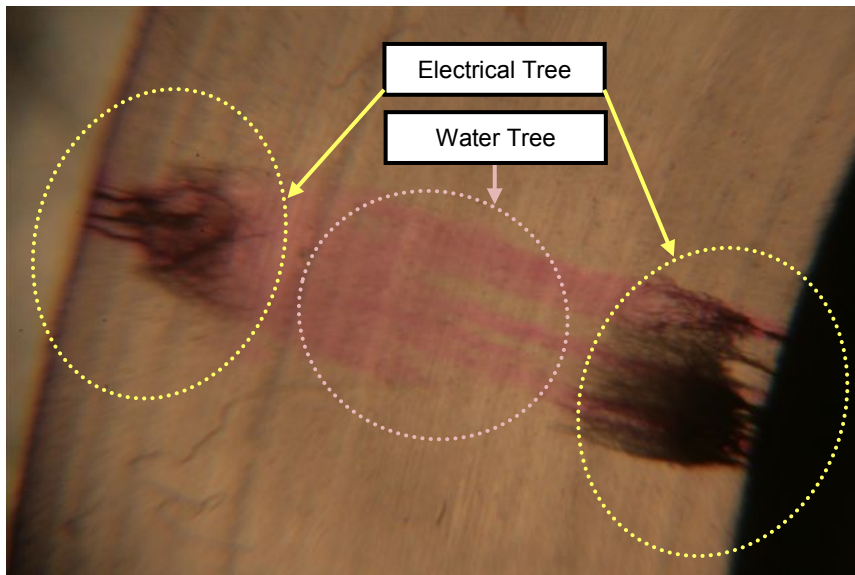

Photo of actual water tree and electrical tree after dissection (XLPE cross section)

12.4.10 Required action and conclusion

After joint dissection, it was found that joint 1 failed due to water ingress that caused corrosion inside the inner sleeve. **Fault location was found in the cable body** near the joint. It was suspected that water had penetrated into the joint and caused the water tree to develop inside the cable body in the joint area. To prevent further cable failures, the whole 2nd section was replaced.

Concluding all test results, **the reason why the PD results didn't indicate the corroded joint Jt.1 is that the wet/moist condition** of the joint influences the PD activity behaviour. The visible corrosion can further indicate the pulse damping effect in the cable.

Furthermore, in such situation that 60% of the cable is WTPCS, it is requested to handle the information of TD results with respect to the VLF test. It is necessary to keep an eye on the '1989 WTPC' being the main reason causing high TD. It is observed that the WTPC of 1989 have reached a status that does not allow guaranteeing safe operation any longer. The VLF testing regulation to apply a VLF test with 2.0U₀ 15mins on XLPE cables with WTPCS was understood to be revised. A monitored withstand test (MWT) would help to find a way to understand the condition of the cable during VLF test and to determine the testing time in dependence of the cable condition and behaviour during the VLF test sequence.

12.5 Case Study H 5 -391

Key points:

- 234m, 11kV, Mixed cable, 5 joints, PD in transition joint
- Water Tree Aging in Water Tree Prone Cable Section
- Mixed Cable with minor PD in transition joints
- TD measurement showing water tree aging (DTD, TD trend analysis, STD)
- Cable Fault 5 days after VLF test
- Dissection of WTP XLPE section

Our Ref:	H5 -391
Date of Test:	06.06.2010 / 10.06.2010
Weather:	Fine
Humidity:	53%
Requested by:	Electricity Company Hong Kong
Cable Location:	Hong Kong Island
Cable Type:	AP 300sqmm / AX/CX 300sqmm
Near end (From):	Hee Wong Terrace 1
Far end (To):	To Li Terrace 15
Pulse Velocity (m/μs)	79.5
Cable Length:	234m
Nominal Voltage:	11kV
Year Of Manufacture:	1976, 1986, 1992, 2002
Number Of Phases:	3 core
Soil Condition	Dry
Joint positions	9m, 68m, 104m, 199m and 224m
Test site:	Hee Wong Terrace 1
<p>Carried out tests: VLF TD ... BAUR Frida TD VLF PD ... BAUR Frida TD + PD portable VLF Test ... Cosine Rectangular VLF test kit</p>	

12.5.1 History

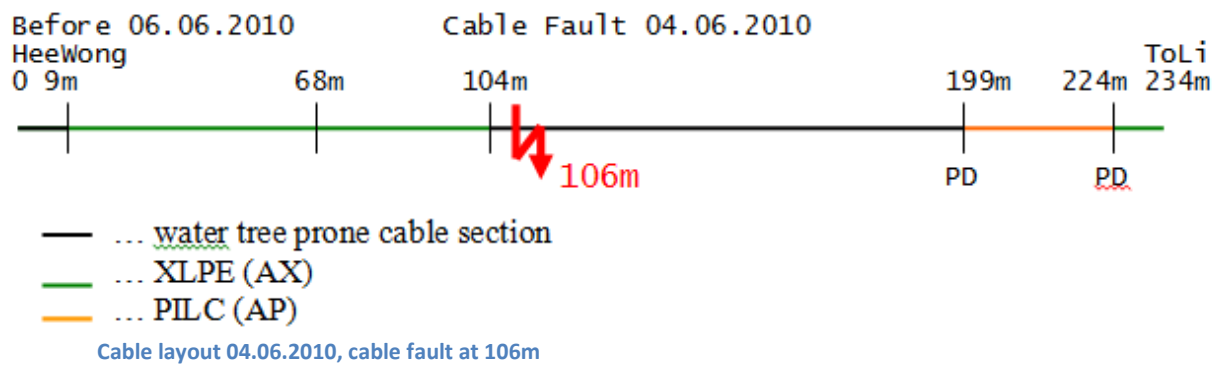

Cable fault on 04.06.2010

- Cable body fault in WTP XLPE cable section (water tree prone cable section)
- Replacement of cable section including the faulty position from 103m to 114m. 85m of WTP XLPE keep remaining.

⇒ Diagnostic test on 06.06.2010 after the repair was completed

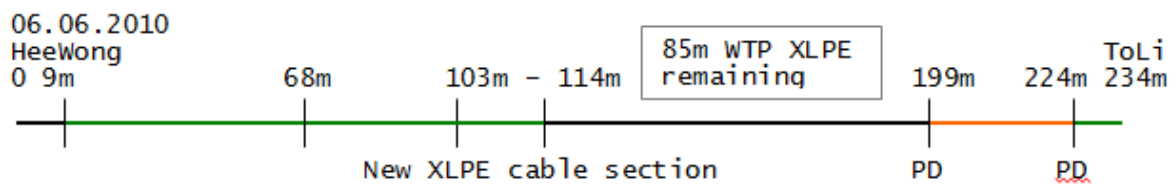

Cable layout 06.06.2010, after replacement of 11m cable section

TD Diagnostic 06.06.2010

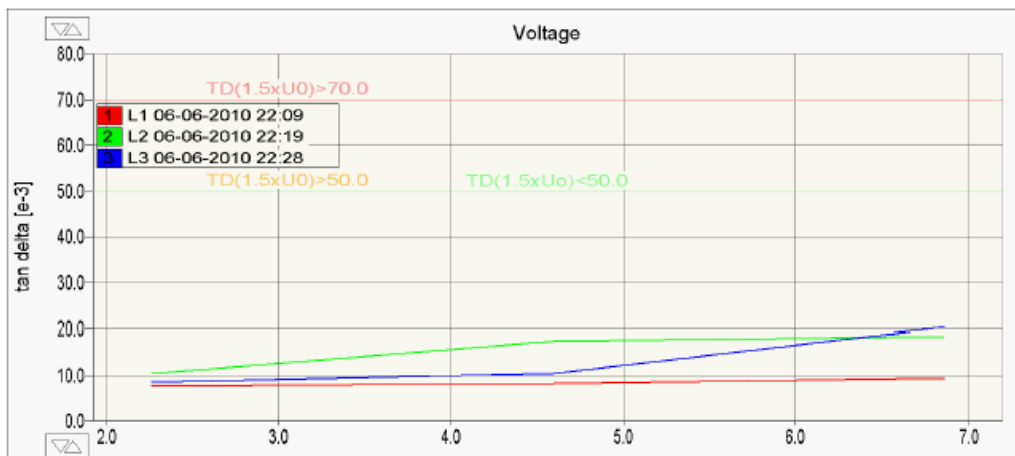

Cable highly service aged

Evaluation

Name of Evaluation	PILG, mixed 1,5U ₀
<i>Criterion</i>	<i>Comment</i>
TD(1.5xU ₀)>70.0	Cable with high operating risk
TD(1.5xU ₀)-(0.5xU ₀)>20.0	Cable with high operating risk
TD(1.5xU ₀)>50.0	Cable highly service aged
TD(1.5xU ₀)-TD(0.5xU ₀)>10.0	Cable highly service aged
TD(1.5xU ₀)<50.0	Cable can be returned to service
TD(1.5xU ₀)-TD(0.5xU ₀)<10.0	Cable can be returned to service

TD result 06.06.2010 interpretation

Overall cable condition Highly service aged condition

Absolute TD values

TD of L1 good condition

TD of L2, L3 increased values at 1.5U₀

TD standard deviation

STD L1 increased valued Indication of water tree aging

STD L2, L3 strongly increased values ... indication of strong water tree aging / humidity in joint

DTD (Delta TD)

DTD L1 very low ... good condition

DTD L2, L3 strong increase ... strong water tree aging

TD trend analysis

L1 ... stable condition

L2, L3 ... increasing trend behaviour Severe water tree aging

As the overall cable evaluation is selected as mixed cables, the “cable highly service aged” condition need to be considered with caution. DTD indicates high water tree aging in XLPE sections. The Water Tree Prone Cable Section is suspected to be highly water tree aged.

- L1 ... Stable, considered as reference
- L2 ... high DTD, very high water tree aging, PD activity with PDIV at U_0
- L3 ... high DTD, moderate water tree aging, PD activity with PDIV < U_0

Std. Deviation – Stability

@ 0,5 U_0 Std.Dev. 0,028 – 0,055 ...**indication of high water tree aging**

@ <0,5 U_0 => PDIV ... indication of high water tree aging + PD activity

Table of Average tan delta value (E-3):

Voltage:	2.3kV	4.6kV	6.9kV
L1	7.762	8.255	9.421
L2	10.452	17.429	18.505
L3	8.615	10.400	20.374

Table of Standard Deviation - Stability:

Voltage:	2.3kV	4.6kV	6.9kV
L1	0.028	0.037	0.083
L2	0.055	1.413	0.600
L3	0.031	0.248	0.532

TD Stability Trend:

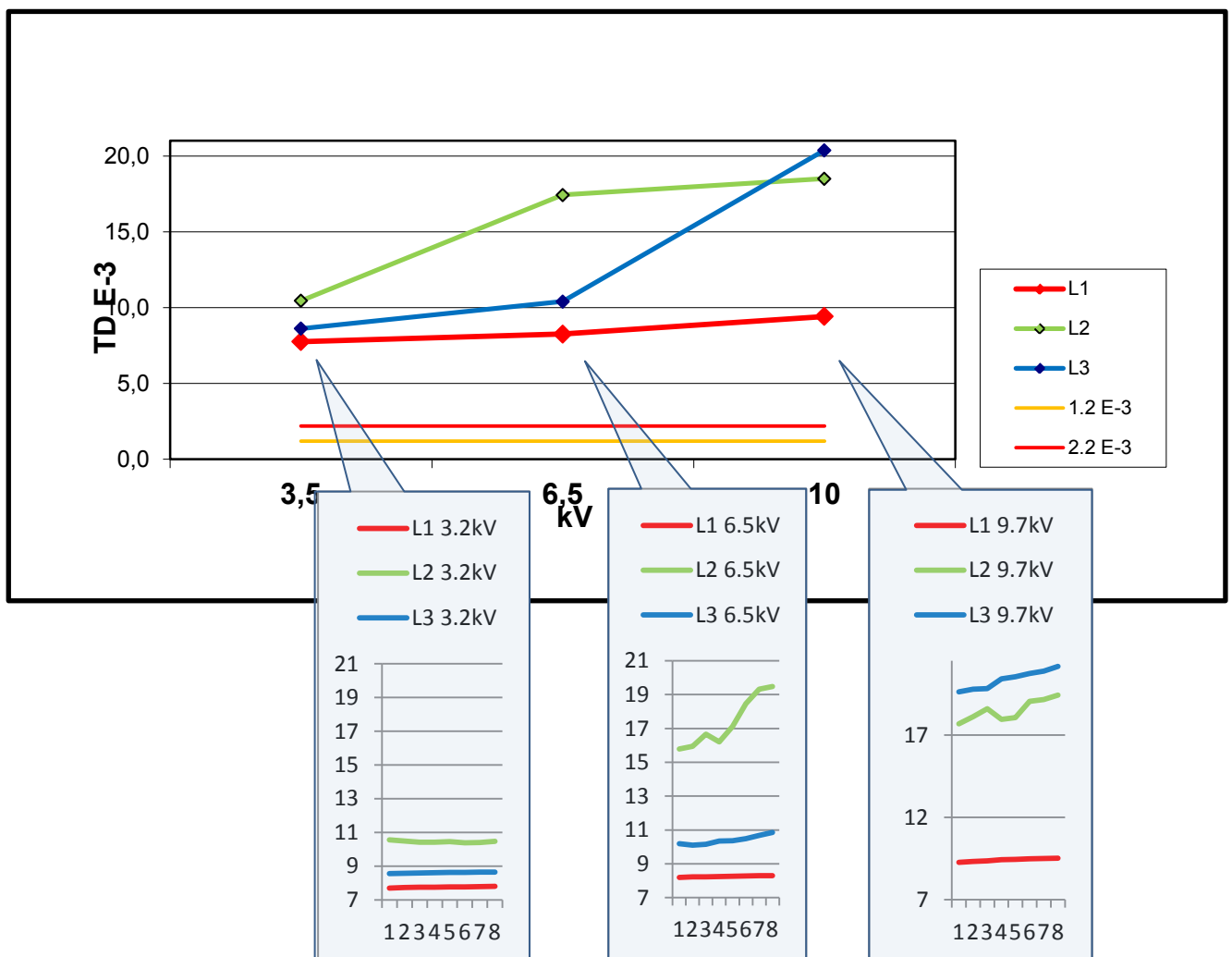

12.5.2 Partial Discharge Measurement 06.06.2010



PD result 06.06.2010

PD activity:

- PD activity at 199m and 224m transition joint in L1,L2,L3
- PD inception voltage 1,5U₀
- up to 500pC /1000pC

=> PD level not serious!

- No immediate action required
- not reflecting in the TD result

12.5.3 TD PD Diagnostic Summary

- TD DTD- values indicate high increase of TD over the voltage
- Indication of **severe water tree aging** in L2 and L3
- PD measurement confirmed that water tree aging is causing the high TD value
- Evaluation criteria applied to mixed cable need to be handled with care.

12.5.4 Further action applied

Due to internal utility regulations at the time where the test was done, every cable had to be tested according to IEEE400.2-2004 before switching back to service. VLF testing was defined to be done by using **cosine rectangular waveform, 2U₀, 15min.**

2U₀, 15min VLF test is considered to be the minimum testing time as per IEEE400.2-2004. Cosine rectangular voltage is proven to be **less efficient compared to sinusoidal waveform** but was the only introduced VLF tester at that time.

Test result:

- **All 3 phases passed the VLF test**, despite the alarming TD value.
- The cable was switched back to operation on 06.06.2010

12.5.5 Further happening

5 days later: 11.06.2010

Cable Fault in L2, WTP XLPE section at 125m

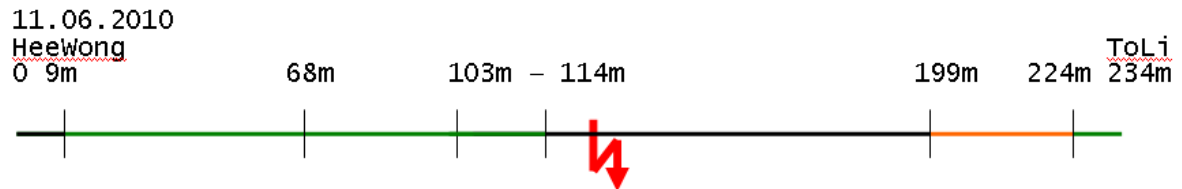

Cable layout 11.06.2010, fault position at 125m



Cable body fault, L2 at 125m

12.5.6 Investigation

Visible Water Trees developed all along the WTP XLPE insulation.

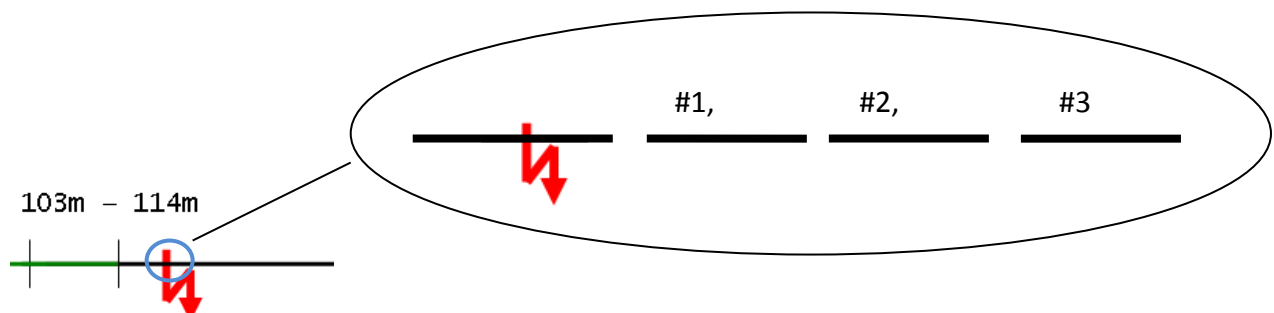

Cable section close to the fault was investigated



Visible white spots after removal of semi conductive layer, section #1, 2, 3



Visible white spots after removal of semi conductive layer, section #1



Dissection of water tree spot section #3



Visible white spots after removal of semiconductive layer

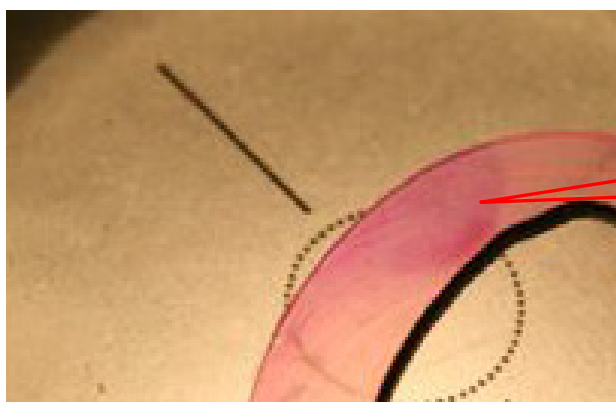

Spot #3 dissection, colored / microscope picture of severe water tree

12.5.7 Conclusion & recommendation

This case study shows that water tree aging is clearly reflected in the TD measurement result. The TD result is mainly influenced by the XLPE insulation. The small PILC cable section does not show signs of degradation as no PD activities are present. The minor PD activity in the transition joints do not influence the TD result a lot.

The evaluation criteria for mixed cables need to be handled carefully.

The VLF test of $2U_0$, 15min appears to be insufficient to detect water tree aging. The weakness of cosine-rectangular test voltage was recognized. Since then, the regulation changed and only sinusoidal VLF testing voltage may be applied.

Further the 15min testing time is recognized to be the main parameter that allows regulating the risk for faults happening after VLF testing.

The implementation of a Monitored Withstand Test MWT will help to find a way to understand the condition of the cable at the end of a VLF test and to determine the testing time in dependence of the cable condition and behavior during the VLF test sequence.

12.5.8 Result of Case Study

- Detect water tree aging with TD measurement
- detect PD activity in transition joint
- show VLF test $2U_0$, 15min, cosine rectangular voltage hides high uncertainty
- Monitored Withstand Test will help to prevent cable failures after VLF test

13 References

13.1 Bibliography

- [1] M. Baur, „Why should we Test Power Cables with Very Low Frequency?“, ALTAE, Mexico, 2007.
- [2] G. Voigt, „New Studies On Site Diagnosis of MV Power Cables by Partial Discharge and“, International Conference & Exhibition on T & D Asset Management for Electric Utilities, Kuala Lumpur, 2008.
- [3] Gockenbach, „Grundsätzliche Untersuchungen zum Durchschlagsverhalten kunststoffisolierter Kabel bei Spannungen unterschiedlicher Frequenz“, BEWAG Symposium, Berlin, 2002.
- [4] S. C. Moh, „Very Low Frequency Testing - It's effectiveness in detecting hidden defects in cables“, CIRED 17th international Conference on Electricity Distribution , Barcelona, 2003.
- [5] www.baur.at, Autor, *VLF Testing and Diagnostic Presentation*. [Performance]. BAUR Prüf- und Messtechnik GmbH, 05-2011.
- [6] Mohaupt, Schlick, „NEW RESULTS IN MEDIUM VOLTAGE CABLE ASSESSMENT USING VERY LOW“, Cired 17th International Conference on Electricity Distribution, Barcelona, 2003.
- [7] IEC60060-3, „High voltage test techniques“, Geneva, Switzerland, 2001.
- [8] IEC60502, „International Standard, Power cables with extruded insulation and their accessories for rated voltages from 1kV up to 30kV“, IEC, Geneva, Switzerland, 2014.
- [9] Cenelec HD 620 (S1), VDE 0267 HD 620 (S1), „Recommended tests after installation“, 1996.
- [10] IEEE400.2-2013, „IEEE Guide for Field Testing of Shielded Power Cable Systems Using Very Low Frequency (VLF)“, IEEE Power and Energy Society, IEEE Standards Association, New York, 2013.
- [11] IEEE400.2-2004, „IEEE Guide for Field Testing of Shielded Power Cable Systems Using Very Low Frequency (VLF)“, IEEE Power Engineering Society, 2004.
- [12] IEEE400.2-2001, „IEEE Guide for Field Testing and Evaluation of the Insulation of Shielded Power Cable Systems“, IEEE Power Engineering Society, 2001.
- [13] Fletcher, Hampton, Hernandez, Hesse, Pearman, Perker, Wall, Zenger, „First Practical Utility Implementations of Monitored Withstand Diagnostics in the USA“, 8th International Conference on Insulated Power Cables , JiCable 2011, France, 2011.
- [14] Bolarin Oyegoke, Petri Hyvönen, Martti Aro, „Dielectric Response Measurement as Diagnostic Tool for Power Cable Systems“, Espoo, Finland, 2001.
- [15] Quresh_et_al, „Diagnostic Techniques for Assessing Water Treeing Degradation of High Voltage XLPE Cables“, King Saud University, Riyadh, Saudi Arabia, 2010.
- [16] Kalkner, Rethmeier, Pepper, „PD-Testing of Service Aged Joints in XLPE-insulated Medium Voltage Cables at Test Voltages with Variable Shape and Frequency“, International Symposium of High Voltage Engineering, Netherlands, 2003.
- [17] HERNANDEZ, HAMPTON, HARLEY, HARTLEIN, „PRACTICAL ISSUES REGARDING THE USE OF DIELECTRIC“, Jicable, Paris, 2007.
- [18] IEEE400.2/D12-2012, „Guide for Field Testing of Shielded Power Cable Systems Using Very Low Frequency (VLF)“, New York, 2012.
- [19] BAUR, „TanDelta Diagnostic Guidelines V4“, 03-2013.

- [20] E. -. G. Toman, „Plant Support Engineering: Aging Management Program Guidance for Medium Voltage Cable Systems for Nuclear Power Plants,“ California, 2010.
- [21] Perkel, Hernandez, Hampton, Drapeau, Densley, Del Valle, „Challenges Associated with the Interpretation of Dielectric Loss data from Power Cable System measurements,“ 8th International Conference on Insulated Power Cables C.4.5, Versailles, France, 2011.
- [22] NEETRAC, „Diagnostic Testing of Underground Cable Systems,“ Neetrac, DEO Award No. DE-FC02-04CH11237, 2010.
- [23] RWE-Eurotest, „Comparison of available measuring methods,“ ew - das magazin fuer die energie wirtschaft, Germany, 2007.
- [24] Kuschel, Kalkner, „Prüfmethoden für Isolierungen mit inneren Grenzflächen – am Beispiel der Diagnostik PE/VPE-isolierter Mittelspannungskabel,“ ETG-Fachtagung, Bad Naumheim, 1999.
- [25] Kuschel, Plath, Stepputat, Kalkner, „Diagnostic Techniques for Service-aged XLPE -Insulated Medium Voltage Cables,“ REE, Berlin, Germany, 1996.
- [26] PowerAssetsHoldings, „Interim Report 2012,“ Power Assets Holdings. Ltd., Hong Kong, 2012.
- [27] Kim et al, „VLF Tan-Delta Criteria for XLPE Insulated Power Cables in Kepco,“ Jicable, Paris, 2011.
- [28] Kim_et_al, „A Study on Three Dimensional Assessment of the Aging Condition of Polymeric Medium Voltage Cables Applying VLF tandelta Diagnostic,“ IEEE Transactions on Dielectrics and Electrical Insulation, 2014.
- [29] Whittaker et al., „Benefits of a Combined Diagnostic Method, using VLF Partial Discharge and Dissipation Factor Measurement on Medium Voltage Distribution Cables.,“ *Conference Proceeding CMD2010*, 2010.

13.2 Table of Figures and Tables

Figure 1 Withstand voltage as a function of the frequency	6
Figure 2 Space Charges in voids of XLPE during DC test [5]	7
Figure 3 Extract of IEC60060-3 definition of maximum distortion value of $\pm 5\%$ [7]	11
Figure 4 Extract IEC 60502-2, page 12, [8].....	12
Figure 5 Extract of CENELEC HD 620 (S1) or VDE 0267 HD 620 S1 (1996) [9]	14
Figure 6 Definition of the purpose of IEEE400.2-2013, [10, p. 2].....	15
Figure 7 Table 3, of IEEE400.2-2013, [10, p. 11].....	17
Figure 8 Extract of IEEE 400.2-2001, 9.3 Method of TD evaluations [12, p. 23]	17
Figure 9 Extract of IEEE 400.2-2013, 5.4 VLF-TD, VLF-DTD, VLF-TDTS with VLF sinusoidal waveform [10, p. 15]	18
Figure 10 participating members in the NEETRAC research organization [13].....	20
Figure 11 Simple VLF Test acc. to IEEE400.2 [10]	20
Figure 12 Schematic of a MWT (black) with Optional Diagnostic Measurement (red) [13]	22
Figure 13 Comparison of Diagnostic Features for Step and Hold portions of MWT [10]	22
Figure 14 Criteria for PILC cables [13].....	22
Figure 15 Test Time Guidance and Condition Assessment for MWT [13].....	23
Figure 16 Tan Delta MWT on service aged XLPE cable [13]	23
Figure 17, illustration of MWT-Ramp up stage.....	25
Figure 18, illustration of MWT / Hold stage	25

Figure 19, Ref. 8438CM, Ramp-up, XLPE stable condition	26
Figure 20, Ref. 8438CM, MWT/Hold phase, XLPE stable time stability	26
Figure 21, Ref. 12518CM, Ramp-up, decreasing trend.....	26
Figure 22, Ref. 12518CM, MWT/Hold phase, XLPE with decreasing t Δ TD.....	26
Figure 23; Ref. 3730-31, Ramp-up, tracking & moisture in L1,	27
Figure 24; Ref. 3730-31, MWT / Hold phase, joint breakdown after 4 minutes.....	27
Figure 25 BAUR VLF TD series: PHG80 TD (57kVrms); VIOLA TD (42,5kVrms); FRIDA TD (24kVrms).....	31
Figure 26 PD Inception voltage on a 110 kV XLPE cable (9,10), [1].....	32
Figure 27 PD levels with 0.1 Hz sinusoidal wave shape, 50 Hz power frequency and Cos-Rectangular 0.1 Hz [16]	32
Figure 28 Partial discharge inception voltage in comparison with HV source [16].....	32
Figure 29 Simplified single line diagram used to describe DPF at one single frequency [12].....	33
Figure 30 Extract of IEEE 400.2-2001, Fig.6 – Phasor diagram for high loss dielectric material [12].....	33
Figure 31 Dissipation factor for new polymer insulated MV cables at 0,1 Hz / 50 Hz, (H: Homopolymer, C: Copolymer, WTR: Water Tree Retardant) [Kus, 1995] Fig. 4 [2]...33	33
Figure 32 Frequency domain spectroscopy of service aged PE and PVC cables [2].....	34
Figure 33 Comparison of non-linearity in the frequency domain of a heavily watertree aged XLPE cable [Kus, 1998] [2]	34
Figure 34 Nonlinearity of DPF at service aged XLPE cables at 0.1Hz and at 50Hz dug out 2008 [2].....	34
Figure 35, water tree with developing level of electrical tree, PD activity	35
Figure 36, water tree, channel shaped structure	35
Figure 37 Illustration of "bow-tie" trees and "vented" trees	35
Figure 38, water tree, channel shaped structure	35
Figure 39 Photo of actual water tree and electrical tree after dissection (XLPE cross section).....	36
Figure 40 Incomplete degassing of the cable in the factory, after 14month in operation	36
Figure 41 Aged XLPE insulation, voids in XLPE, 115kV cable	36
Figure 42 Cumulative distribution functions TanDelta field data for >10.360m of cable measured [17].....	37
Figure 43 cable section with non-uniform water tree degradation	38
Figure 44 Evaluation criteria adapted to 0.5U _o to 1,5U _o [17]	39
Figure 45 Evaluation of TD results, TD Average Value Criteria [19]	40
Figure 46 Evaluation of TD results, DTD [19]	40
Figure 47 Evaluation of TD results, Phase comparison [19]	40
Figure 48 TD Stability Trend interpretation [19]	42
Figure 49 TD trend pattern - XLPE in good condition [19].....	45
Figure 50 TD trend pattern, XLPE with high water tree aging [19]	46
Figure 51 TD trend pattern, XLPE with PD activities in joints [19]	47
Figure 52 TD trend pattern, XLPE with joint with minor water ingress, tracking [19]	48
Figure 53 TD Trend pattern, PILC without PD activities [19]	49
Figure 54 TD Trend pattern, PILC cable with PD activities [19]	50
Figure 55 TD Trend pattern, PILC cable with tracking in a joint, minor PD activities [19]	51
Figure 56 TD Trend pattern, PILC cable, highly service aged, minor PD activities [19].....	52
Figure 57, Ref. 2215CM, example L2, L3 stable condition, L1 water ingress in a joint	54
Figure 58, Ref. 8444CM, example L2, L3 tracking in joint, L1 stable condition.....	54
Figure 59 TD comparison of same XLPE cable after 1year; visible aging effect	55

Figure 60 Programmable High voltage Generator (PHG) Connection Diagram for TD with guard ring application.....	56
Figure 61 Guard Ring connection technique with VSE box	56
Figure 62 direct comparison of the TD value with guard ring application and without guard ring application	57
Figure 64, connection arrangement with guard ring and corona hoods (left), without guard ring (right); relative humidity 80%, 30°C.....	57
Figure 63, connection arrangement with guard ring and corona hoods, VSE box, Frida TD connection	57
Figure 65 Some possible cases for a cable section with non-uniform water tree degradation [17].....	58
Figure 70 Hysteresis of dissipation factor TD at VLF voltage rise and voltage decay [1]	62
Figure 75 Table 5-1 - EPRI TanDelta Assesment Criteria for EPR Butyl Rubber cables [20]	66
Figure 76 Table 5-2 - EPRI TanDelta Assesment Criteria for Black EPR cables [20].....	66
Figure 77 Table 5-3 - EPRI TanDelta assesment criteria for Pink EPR cables [20].....	67
Figure 78 Table 5-4 - EPRI Tan Delta assesment Criteria for Brown EPR cables [20].....	67
Figure 80 TD Tip Up distribution in Filled, PILC and PE cables [21]	68
Figure 81 BAUR PHG 70/80 TD PD	69
Figure 82 BAUR Frida TD + PD TaD 60	69
Figure 83 PD Localization Graph of a XLPE cable with 3 joints with PD activity.....	69
Figure 84 PD portable connection diagram.....	70
Figure 85 Test setup of BAUR VLF PD System.....	70
Figure 86 Sequence of graphical PD pulse localization	71
Figure 87 typical example of scattered PD activity along a PILC section	72
Figure 88 typical example of a XLPE cable with muliptle joints showing PD activity	72
Figure 89 PD coupler CU60 with Calibrator	73
Figure 90 Screenshot of BAUR PD software - Calibration graph	73
Figure 91 Calibration graph of a cable with 295m without any joint.....	73
Figure 92 Calibration graph of a new XLPE cable with 6 equal sections and 5 joints	74
Figure 93 Table 11 of, TDR graph interpretation to identify cable conditions [22]	74
Figure 94 calibration graph with identification of several joints. e.g. 491.5m.....	75
Figure 95, calibration graph with identification of a joint with water ingress at 260m.....	75
Figure 96, calibration graph with identification of joint with water ingress at 656.5m.....	75
Figure 97 Matrix of all the measurements performed on the model faults in joints (the boxes with a colour background indicate detected and localized discharge activity) [23].....	76
Figure 98 Portable on-site PD detector with PD location (BAUR PD portable).....	77
Figure 99 PD graph of XLPE cable with PD activity concentrated at 3 joints	79
Figure 100 PD graph of mixed cable with scattered PD activity in PILC section	80
Figure 101 Survey of diagnostic techniques [24].....	81
Figure 102 Basic measurement circuit for the IRC – Analysis, KDA1.....	82
Figure 103 (picture 5 [24]), prinzipal of selected time-range based diagnostic method	82
Figure 104 (picture 7 of [24]), depolarization current of different water tree damaged PE/VPE cables	82
Figure 105 Block Diagram of the return voltage method [14]	83
Figure 107 picture 6 from [24], Comparison between the Return voltage calculated from Depolarization current and the practically measured return voltage.....	83
Figure 106 picture 9 of [24], Return voltage peak for differently aged PE/VPE cables.....	83
Figure 108 Fig. 10 of [22] Schematic block diagram IDA 200 - system.....	84

Figure 100, Tan Delta measurement [14]	85
Figure 101 example of TD values of a new XLPE cable, low Std.dev., deviating L1 only visible with sensitive measuring range.....	86
Figure 102, PD activity in L1, inception voltage 19kV, 450pC at 1,7U _o , far end termination.....	86
Figure 112 TD result 10.01.2008, high operating risk, decreasing DTD, influence of water ingress in joint.....	87
Figure 113 TD result 30.12.2008, high operating risk, no water influence	87
Figure 114 HK Electric company profile 10/2010 [26].....	95
Figure 106; HK Electric Testing Philosophy 2012.....	96
Figure 116 HKE statistical review of cable categorization.....	97
Figure 117: BAUR VLF TD / PD Systems used	97
Figure 118: KEPCO Diagnostic Experience	98
Figure 119: extract of resent paper by KEPCO 2013 [27] [28].....	99
Figure 120: Benefits of a combined diagnostic method CMD 2010 [29]	100
Figure 121 PD result of Phase 1 13.07.2011	131
Figure 122 PD result of Phase 2 13.07.2011	131
Figure 123 PD result Phase 3 13.07.2011	131
Figure 124 PD result of 3 Phases 13.07.2011	131
Table 1 overview testing and diagnostic standards for MV cables	10
Table 2 overview testing and diagnostic standards for HV and EHV cables	11
Table 3, Table 2, page 9 of IEEE400.2,2013, [10, p. 9] Usefulness of VLF TD PD Testing and Diagnostic methods	19
Table 4 practical implementation of testing voltages in relation to the selected testing instrument Viola TD PD.....	28
Table 5, TD Stability interpretation, suitable as general guideline [19]	41
Table 6, overview of TD trend pattern	43
Table 7, IEEE400.2-2013 for XLPE cables 1.0 - 2.0 U _o [10, p. 48]	59
Table 8, IEEE400.2-2013, International figures for PILC cables (1.0U _o to 2.0U _o) [10, p. 49]	60
Table 9, Adjusted table I.1 of IEEE400.2-2013 acc. to BAUR experience for 0.5U _o to 1.5U _o XLPE Cables	60
Table 10, Adjusted table I.4 of IEEE400.2-2013 acc. to BAUR experience for 0.5U _o to 1.5U _o PILC & Mixed Cables.....	61
Table 11,Table I1/I2 IEEE400.2-2013,[10, pp. 48-49], ANNEX I, Evaluation criteria for outside North America.....	63
Table 12, Table I3/ I4, IEEE400.2-2013, [10, pp. 48-49], ANNEX I, Evaluation criteria for outside North America.....	64
Table 13, Table 4, IEEE400.2-2013[10, p. 19] – Evaluation Criteria for service aged PE-based insulation.....	64
Table 14, Table 5, IEEE400.2-2013 [10, p. 20] - Evaluation Criteria for service aged filled cables (EPR's)	65
Table 15, Table 7, page 21, IEEE400.2-2013 [10, p. 21] - Evaluation Criteria for service aged PILC cables.....	68

The Author:

Tobias Neier was born in Austria in 1981 and graduated as Engineer of Electrical Engineering in Austria and MBA in Hong Kong. Working experience with BAUR Prüf- und Messtechnik GmbH since 2002 as lecturer for Training Seminars in Technical Institutes and Power Utilities allowed gaining worldwide experience in the specific fields of Cable Testing and Diagnosis Technology as well as Cable Fault Location.

Consultancy work and support for strategy development with numerous power utilities especially in Asia allowed to gain extensive experience in applied testing and diagnostic of underground cables networks.

International field experience and background knowledge of the applied theories and technologies was gained during most interesting years of travelling through more than 30 countries in Europe, North Africa and all over Asia.

t.neier@baur.at

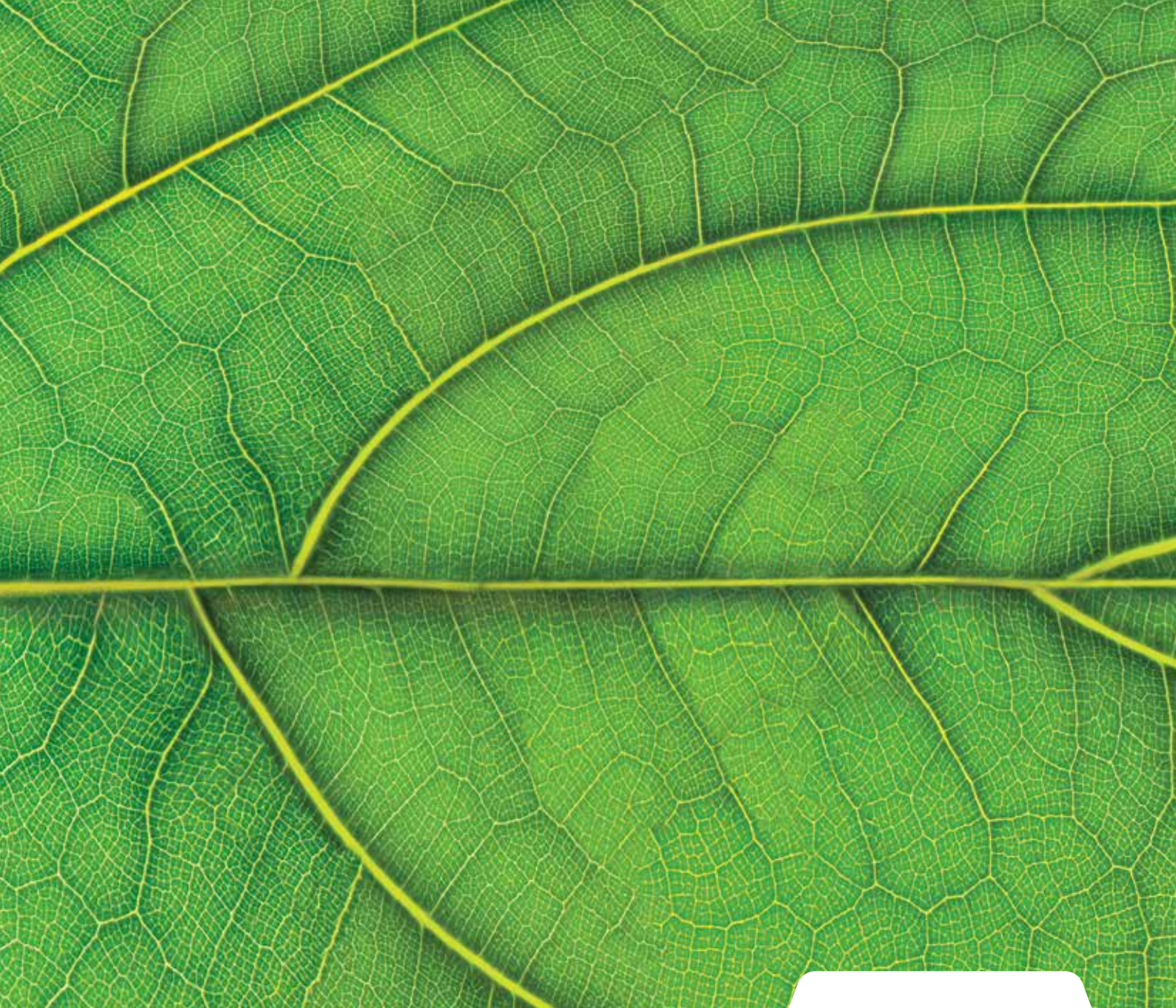

BAUR Prüf- und Messtechnik GmbH · Raiffeisenstraße 8 · 6832 Sulz, Austria
T +43 5522 4941 0 · F +43 5522 4941 3 · headoffice@baur.at
www.baur.eu

Art. nr. 821-071, version 3.0, 02/15 Information subject to change. Subject to modifications.